

CONFIGURATION

/S Modifier 65-45-12 Ductile Iron, Buna-N, Chem. Black

TECHNICAL DATA

Body Type	Line mount
Interface	1.25 SAE C61
Body Features	Direct mount
Open Cavities	1
Cavity	T-17A
Port Size	1 1/4" Code 61
Model Weight	8.78 lb.

NOTES

Important: Carefully consider the maximum system pressure. The pressure rating of the manifold is dependent on the manifold material, with the port type/size a secondary consideration. Manifolds constructed of aluminum are not rated for pressures higher than 3000 psi (210 bar), regardless of the port type/size specified.

PORT DESIGNATORS

Modifiers	Ports
ZJY, /10, /11, /15, /16, /V	Ports 1 & 2: 1 1/4" Code 61; Port 3: SAE 6;
ZJY/1A, /1B, /1F, /1G, /M, /Z	Ports 1 & 2: 1 1/4" Code 61; Port 3: 1/4" BSPP;

INCLUDED COMPONENTS

Part	Description	Quantity
500-001-222	O-Ring	1

CONFIGURATION OPTIONS

Model Code Example: ZJY/S

MODIFIER (S)

- /S** 65-45-12 Ductile Iron, Buna-N, Chem. Black
- 6061-T651 Aluminum, Buna-N
- /11** 6061-T651 Aluminum, Buna-N, Clear Anodize - Per MIL SPEC 8625F Type II, Class I
- /10** 6061-T651 Aluminum, Buna-N, Black Anodize - Per MIL SPEC 8625F Type II, Class II
- /V** 6061-T651 Aluminum, Viton
- /16** 6061-T651 Aluminum, Viton, Clear Anodize - Per MIL SPEC 8625F Type II, Class I

- /15** 6061-T651 Aluminum, Viton, Black Anodize - Per MIL SPEC 8625F Type II, Class II
- /M** 6061-T651 Aluminum, Metric, Buna-N
- /1B** 6061-T651 Aluminum, Metric, Buna-N, Clear Anodize - Per MIL SPEC 8625F Type II, Class I
- /1A** 6061-T651 Aluminum, Metric, Buna-N, Black Anodize - Per MIL SPEC 8625F Type II, Class II
- /Z** 6061-T651 Aluminum, Metric, Viton
- /1G** 6061-T651 Aluminum, Metric, Viton, Clear Anodize - Per MIL SPEC 8625F Type II, Class I
- /1F** 6061-T651 Aluminum, Metric, Viton, Black Anodize - Per MIL SPEC 8625F Type II, Class II
- /S3** 65-45-12 Ductile Iron, Buna-N, Trivalent Clear Zinc with Top Sealer
- /Y** 65-45-12 Ductile Iron, Viton, Chem. Black
- /Y3** 65-45-12 Ductile Iron, Viton, Trivalent Clear Zinc with Top Sealer
- /T** 65-45-12 Ductile Iron, Metric, Buna-N, Chem. Black
- /T3** 65-45-12 Ductile Iron, Metric, Buna-N, Trivalent Clear Zinc with Top Sealer
- /W** 65-45-12 Ductile Iron, Metric, Viton, Chem. Black
- /W3** 65-45-12 Ductile Iron, Metric, Viton, Trivalent Clear Zinc with Top Sealer

MANIFOLD FACES

FACE GRID

1	2	3	4
5	6	7	8
9	10	11	12

Face 2

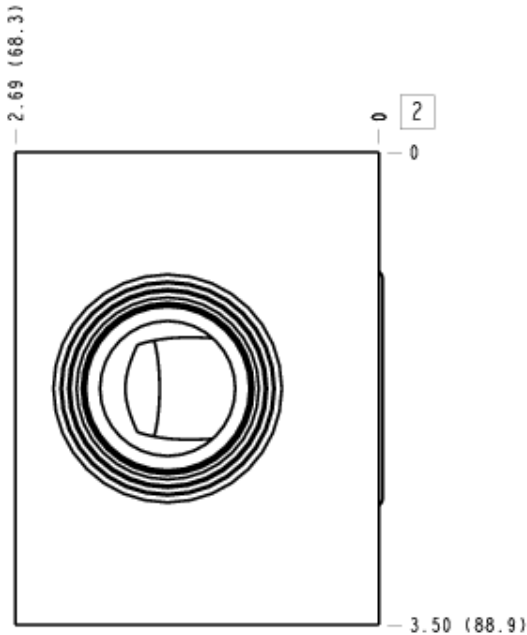

Face 5

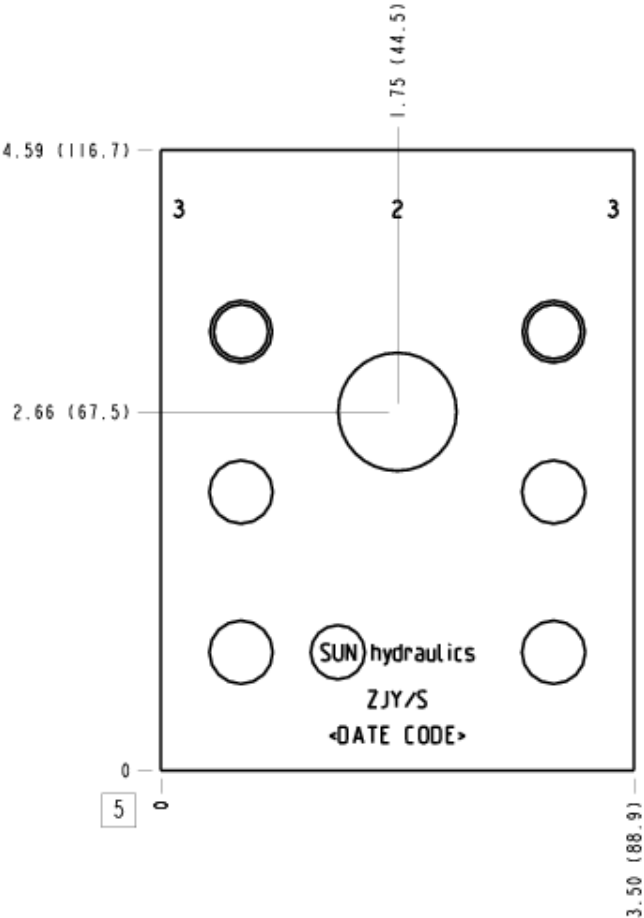

Face 6

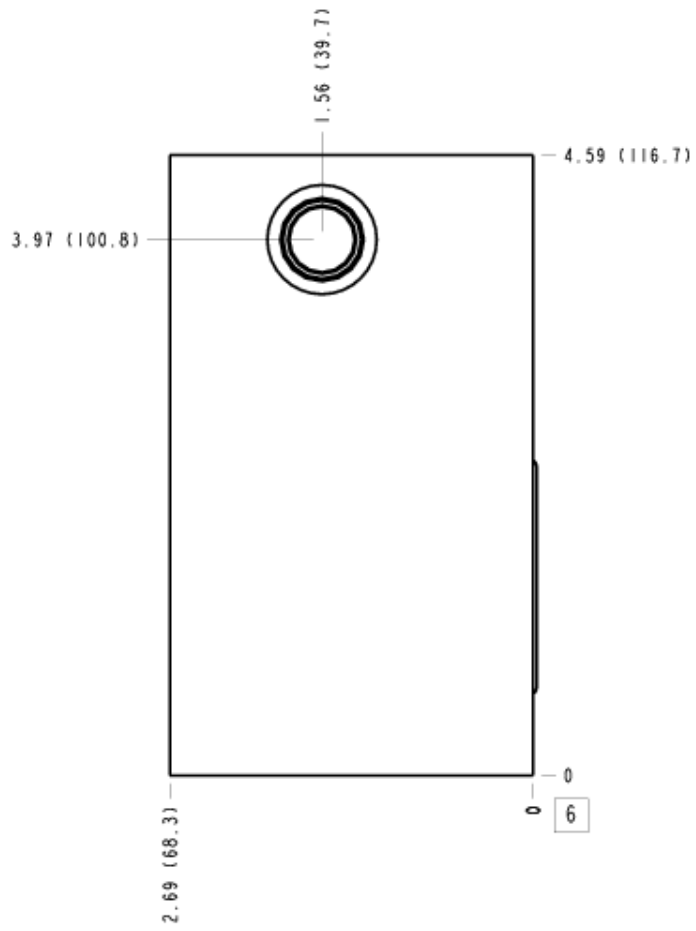

Face 7

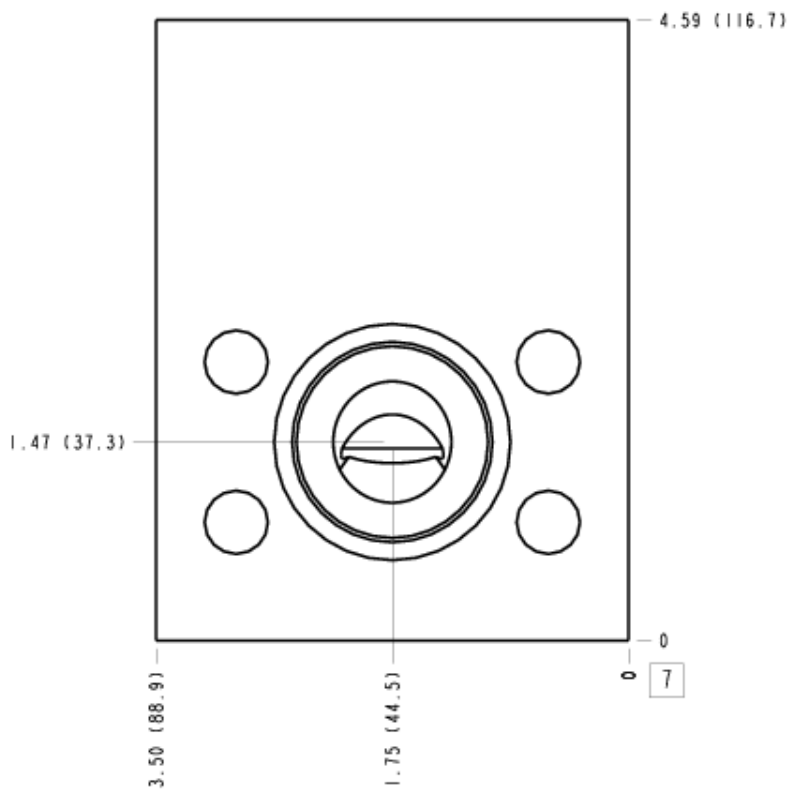

Face 8

