

Functional Group:

Model:

Products : Manifolds : Sandwich : Reducing/Relieving : ISO 05 : On P, tank to T, high capacity

WCC

Face : 6

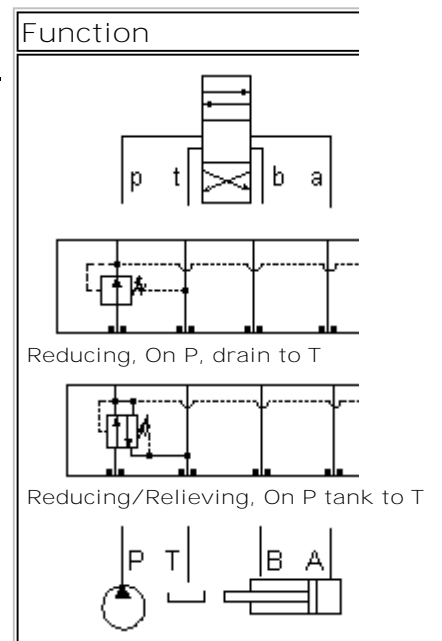
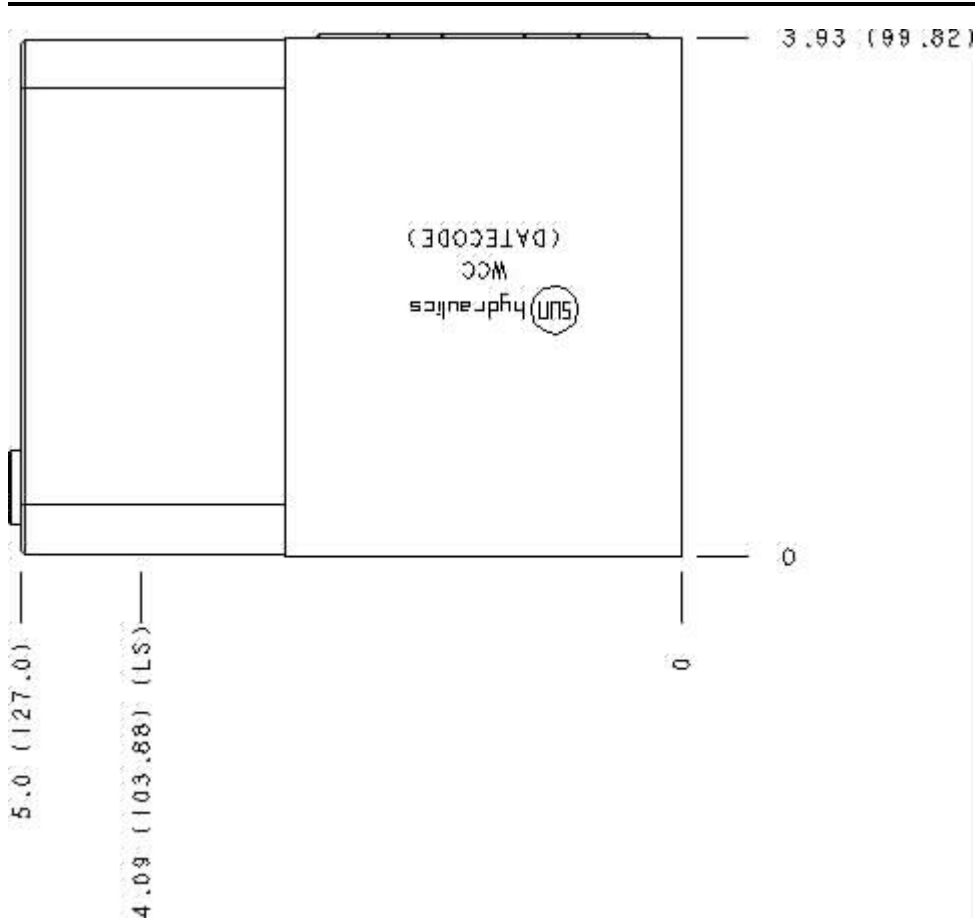

Cartridge extension measurement is to the centerline of the cartridge.

Aluminum Body Pressure Rating: **3000 psi (210 bar)**
 Ductile Iron Body Pressure Rating: **5000 psi (350 bar)**

Port Headings and Sizes:

Gage Port (Plugged)
 1/4" BSPP

Gage Port (Plugged)
 1/4" NPTF

Technical Data

	U.S. Units	Metric Units
Model Weight	3.89 lb.	1.76 kg.
Cavity	T-17A	
Body Features	On P, port 3 to T	

Body Type	Sandwich	
Interface	ISO 05	
Open Cavity Quantity	1	
Stack Height	3.94 in.	

Option Selection:

Model Code	Description
WCC	Aluminum, Buna-N, U.S. Units
WCC/M	Aluminum, Buna-N, Metric
WCC/S	Ductile Iron, Buna-N, U.S. Units
WCC/T	Ductile Iron, Buna-N, Metric
WCC/V	Aluminum, Viton, U.S. Units
WCC/W	Ductile Iron, Viton, Metric
WCC/Y	Ductile Iron, Viton, U.S. Units
WCC/Z	Aluminum, Viton, Metric

Special Notes :

No Special Notes available for selected Model.



Functional Group:
 Products : Manifolds : Sandwich : Reducing/Relieving : ISO 05 : On P, tank to
 T, high capacity

Model:
 WCC

Face : 2

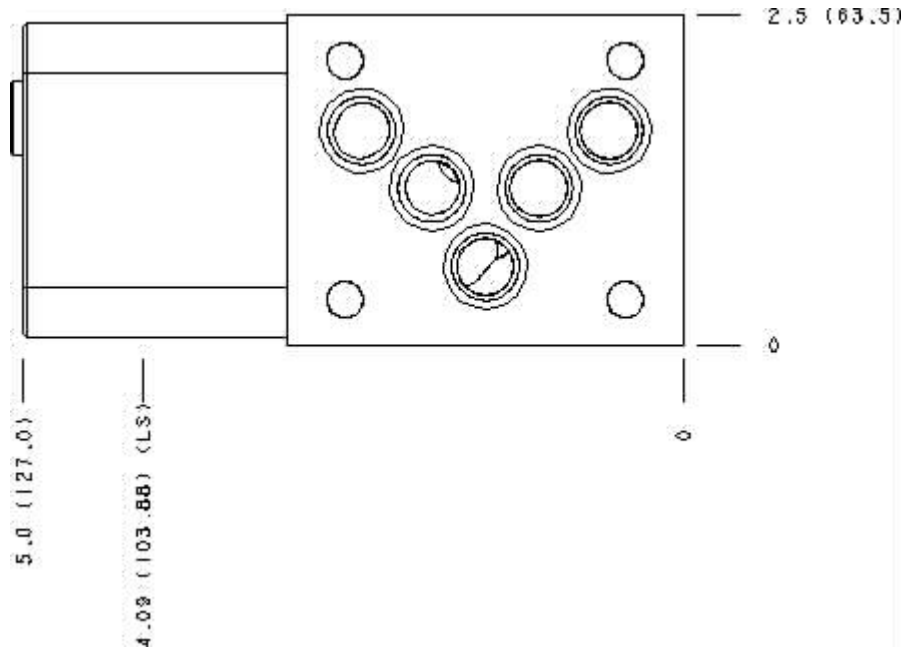

Cartridge extension measurement is to the centerline of the cartridge.



Functional Group:
 Products : Manifolds : Sandwich : Reducing/Relieving : ISO 05 : On P, tank to
 T, high capacity

Model:
 WCC

Face : 5

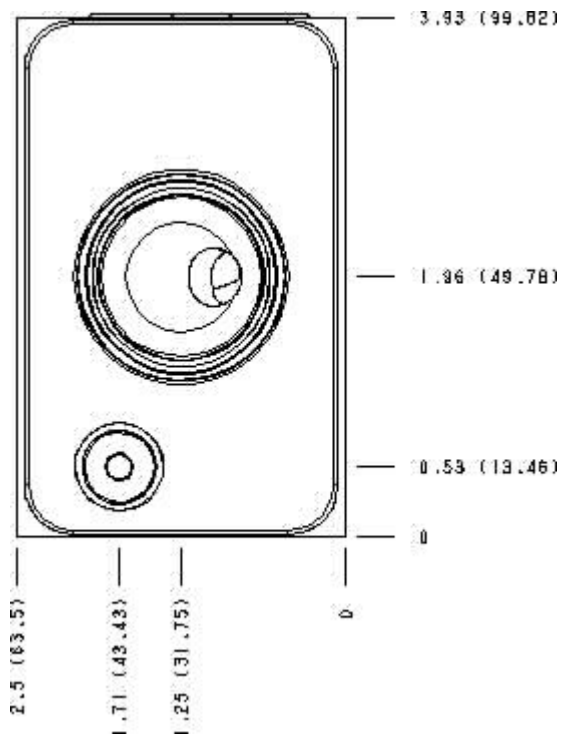

Cartridge extension measurement is to the centerline of the cartridge.

Functional Group:
Products : Manifolds : Sandwich : Reducing/Relieving : ISO 05 : On P, tank to
T, high capacity

Model:
WCC

Face : 7

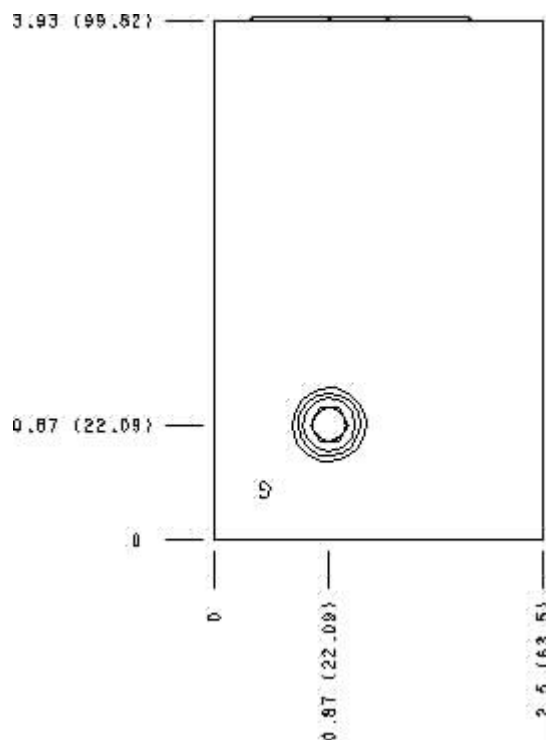

Cartridge extension measurement is to the centerline of the cartridge.

Functional Group:
Products : Manifolds : Sandwich : Reducing/Relieving : ISO 05 : On P, tank to
T, high capacity

Model:
WCC

Face : 10

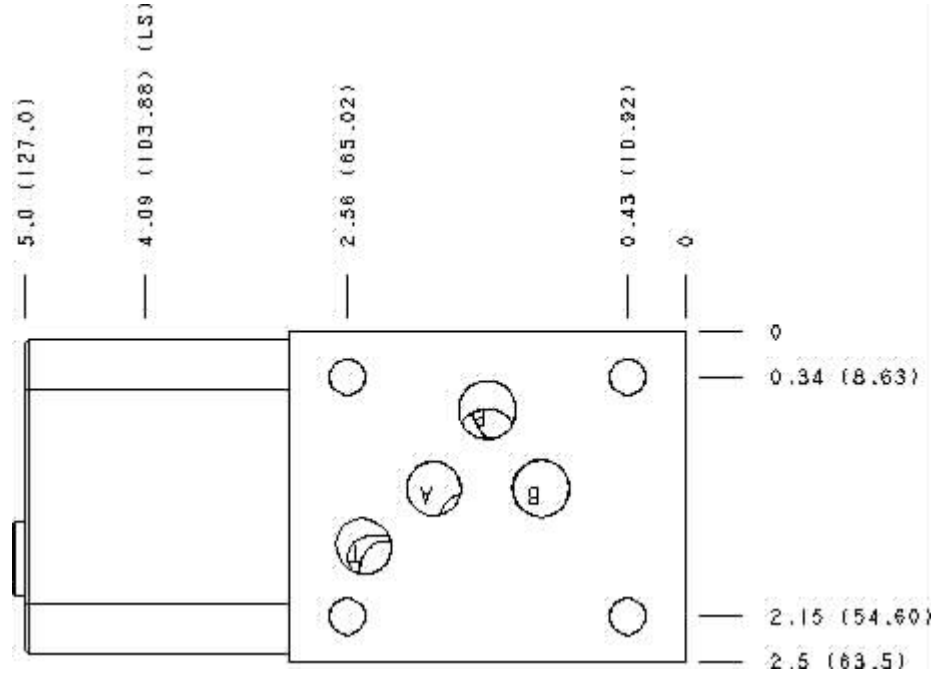

Cartridge extension measurement is to the centerline of the cartridge.



Functional Group:

Products : Manifolds : Sandwich : Reducing/Relieving :
 ISO 05 : On P, tank to T, high capacity

Model:
 WCC

Projection Type

All Dimensions in Inches(mm)

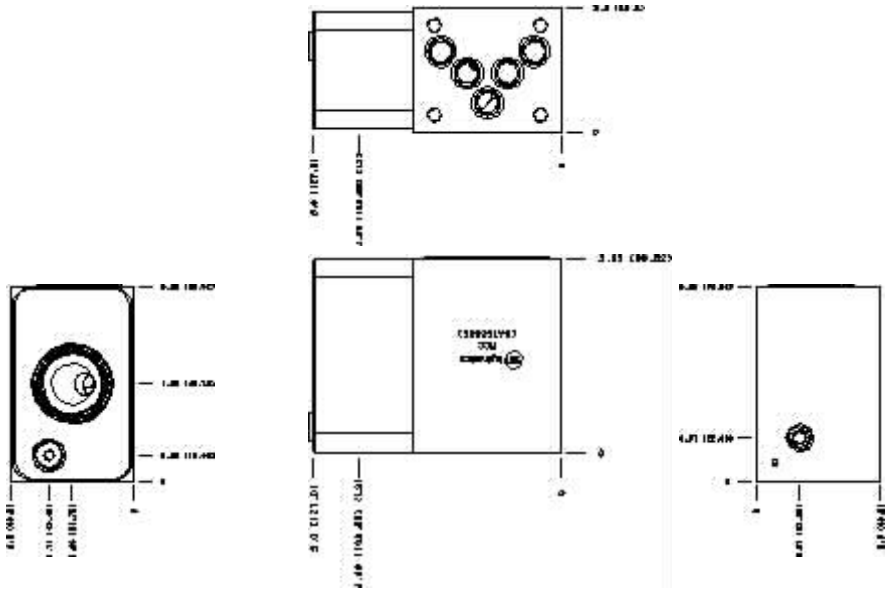

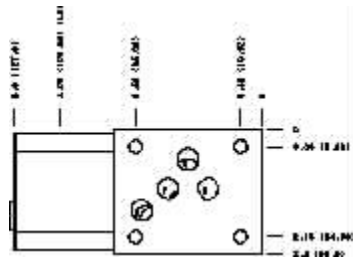

Copyright © 2007-2008 Sun Hydraulics Corporation.
All rights reserved.

[Terms and Conditions](#) - [Statement of Privacy](#)