

Butt Weld Pipe

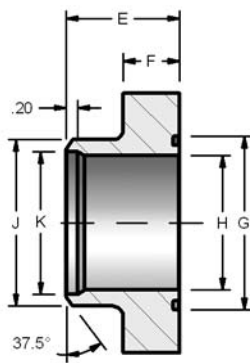
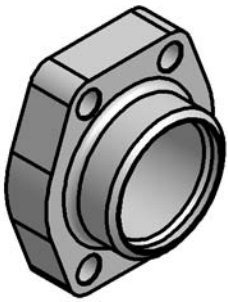

Figure 1

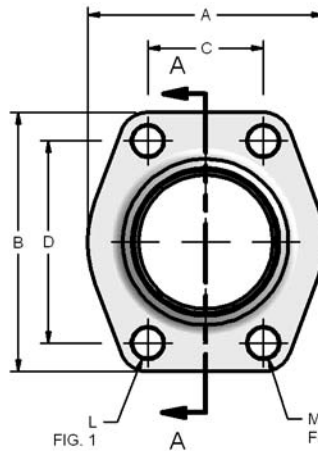

FIG. 1 A M FIG. 2

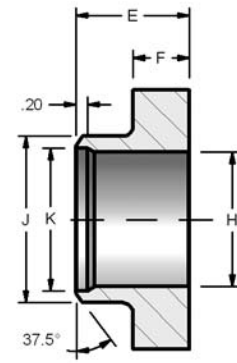

Figure 2

CODE 61 BUTT WELD - SCHEDULE 40 PIPE

PART NO. O-RING FIG. 1	PART NO. FLAT FACE FIG. 2	PIPE SIZE	PAD SIZE	A	B	C	D	E	F	G	H	J	K	L	M UNC-2B	MOUNTING HARDWARE	
																O-RING	SHCS
W35-8	W34-8	.50	.50	1.81	2.13	.688	1.500	1.42	.63	1.000	.548	.840	.624	.344	5/16-18	210	5/16-18X1.25
W35-12	W34-12	.75	.75	1.97	2.56	.875	1.875	1.42	.71	1.250	.744	1.050	.846	.406	3/8-16	214	3/8-16X1.50
W35-16	W34-16	1.00	1.00	2.17	2.75	1.031	2.062	1.50	.71	1.560	.959	1.315	1.051	.406	3/8-16	219	3/8-16X1.50
W35-20	W34-20	1.25	1.25	2.68	3.12	1.188	2.312	1.61	.83	1.750	1.280	1.660	1.382	.469	7/16-14	222	7/16-14X1.75
W35-24	W34-24	1.50	1.50	3.07	3.66	1.406	2.750	1.73	.98	2.115	1.502	1.900	1.612	.531	1/2-13	225	1/2-13X1.75
W35-32	W34-32	2.00	2.00	3.54	4.00	1.688	3.062	1.77	.98	2.490	1.941	2.375	2.069	.531	1/2-13	228	1/2-13X1.75
W35-40	W34-40	2.50	2.50	4.09	4.49	2.000	3.500	1.97	.98	2.995	2.325	2.875	2.471	.531	1/2-13	232	1/2-13X1.75
W35-48	W34-48	3.00	3.00	4.88	5.28	2.438	4.188	1.97	1.06	3.615	2.902	3.500	3.070	.656	5/8-11	237	5/8-11X2.00

CODE 61 BUTT WELD - SCHEDULE 80 PIPE

PART NO. O-RING FIG. 1	PART NO. FLAT FACE FIG. 2	PIPE SIZE	PAD SIZE	A	B	C	D	E	F	G	H	J	K	L	M UNC-2B	MOUNTING HARDWARE	
																O-RING	SHCS
W24-8	W23-8	.50	.50	1.81	2.13	.688	1.500	1.42	.63	1.000	.548	.840	SCHEDULE 40 ONLY	.344	5/16-18	210	5/16-18X1.25
W24-12	W23-12	.75	.75	1.97	2.56	.875	1.875	1.42	.71	1.250	.744	1.050		.406	3/8-16	214	3/8-16X1.50
W24-16	W23-16	1.00	1.00	2.17	2.75	1.031	2.062	1.50	.71	1.560	.959	1.315		.406	3/8-16	219	3/8-16X1.50
W24-20	W23-20	1.25	1.25	2.68	3.12	1.188	2.312	1.61	.83	1.750	1.280	1.660		.469	7/16-14	222	7/16-14X1.75
W24-24	W23-24	1.50	1.50	3.07	3.66	1.406	2.750	1.73	.98	2.115	1.502	1.900		.531	1/2-13	225	1/2-13X1.75
W24-32	W23-32	2.00	2.00	3.54	4.00	1.688	3.062	1.77	.98	2.490	1.941	2.375		.531	1/2-13	228	1/2-13X1.75
W24-40	W23-40	2.50	2.50	4.09	4.49	2.000	3.500	1.97	.98	2.995	2.325	2.875		.531	1/2-13	232	1/2-13X1.75
W24-48	W23-48	3.00	3.00	4.88	5.28	2.438	4.188	1.97	1.06	3.615	2.902	3.500		.656	5/8-11	237	5/8-11X2.00

CODE 61 BUTT WELD - SCHEDULE 160 PIPE

PART NO. O-RING FIG. 1	PART NO. FLAT FACE FIG. 2	PIPE SIZE	PAD SIZE	A	B	C	D	E	F	G	H	J	K	L	M UNC-2B	MOUNTING HARDWARE	
																O-RING	SHCS
W27-8	W25-8	.50	.50	1.81	2.13	.688	1.500	1.42	.63	1.000	.466	.840	SCHEDULE 40 ONLY	.344	5/16-18	210	5/16-18X1.25
W27-12	W25-12	.75	.75	1.97	2.56	.875	1.875	1.42	.71	1.250	.614	1.050		.406	3/8-16	214	3/8-16X1.50
W27-16	W25-16	1.00	1.00	2.17	2.75	1.031	2.062	1.50	.71	1.560	.817	1.315		.406	3/8-16	219	3/8-16X1.50
W27-20	W25-20	1.25	1.25	2.68	3.12	1.188	2.132	1.61	.83	1.750	1.162	1.660		.469	7/16-14	222	7/16-14X1.75
W27-24	W25-24	1.50	1.50	3.07	3.66	1.406	2.750	1.73	.98	2.115	1.340	1.900		.531	1/2-13	225	1/2-13X1.75
W27-32	W25-32	2.00	2.00	3.54	4.00	1.688	3.062	1.77	.98	2.490	1.689	2.375		.531	1/2-13	228	1/2-13X1.75
W27-40	W25-40	2.50	2.50	4.09	4.49	2.000	3.500	1.97	.98	2.995	2.127	2.875		.531	1/2-13	232	1/2-13X1.75
W27-48	W25-48	3.00	3.00	4.88	5.28	2.438	4.188	1.97	1.06	3.615	2.626	3.500		.656	5/8-11	237	5/8-11X2.00

*NOTE: Also available in sizes 3 1/2", 4", and 5". Consult factory for specifications.