

Socket Weld Elbow

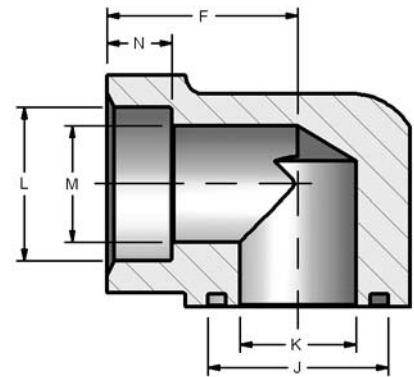
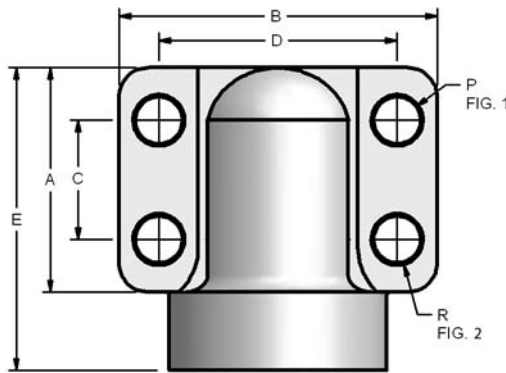
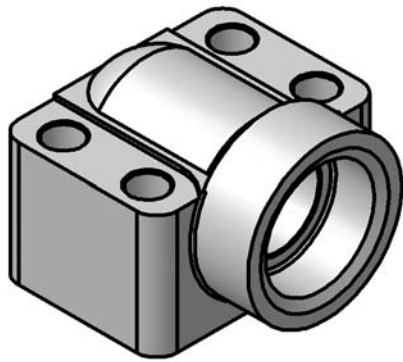

Figure 1

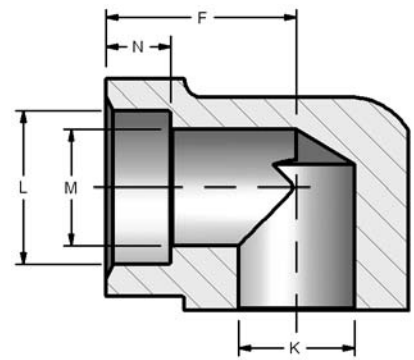
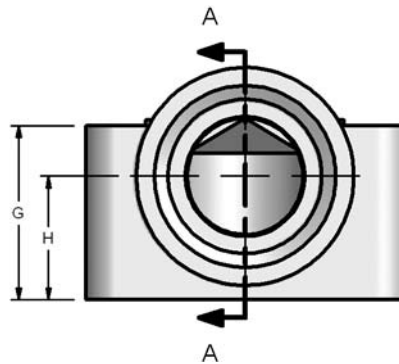

Figure 2

CODE 61 ELBOW SOCKET WELD - PIPE

PART NO. O-RING FIG. 1	PART NO. FLAT FACE FIG. 2	PAD SIZE	A	B	C	D	E	F	G	H	J	K	L	M	N	P	R UNC-2B	MOUNTING HARDWARE	
																		O-RING	SHCS
W176-12-12	W169-12-12	.75	1.69	2.56	.875	1.875	2.28	1.44	1.25	.875	1.250	.752	1.062	.75	.56	.406	3/8-16	214	3/8-16X2.00
W176-16-16	W169-16-16	1.00	1.94	2.75	1.031	2.062	2.62	1.66	1.50	1.062	1.560	1.002	1.328	1.00	.56	.406	3/8-16	219	3/8-16X2.25
W176-20-20	W169-20-20	1.25	2.19	3.12	1.188	2.312	3.00	1.91	1.81	1.188	1.750	1.252	1.672	1.25	.62	.469	7/16-14	222	7/16-14X2.75
W176-24-24	W169-24-24	1.50	2.56	3.69	1.406	2.750	3.33	2.05	2.00	1.312	2.115	1.502	1.922	1.50	.69	.531	1/2-13	225	1/2-13X3.00
W176-32-32	W169-32-32	2.00	3.06	4.33	1.688	3.062	3.81	2.28	2.50	1.656	2.490	2.002	2.406	2.00	.75	.531	1/2-13	228	1/2-13X3.50
W176-40-40	W169-40-40	CONSULT PAGE 45 FOR DIMENSIONS																	
W176-48-48	W169-48-48	CONSULT PAGE 45 FOR DIMENSIONS																	

CODE 61 ELBOW SOCKET WELD - TUBE

PART NO. O-RING FIG. 1	PART NO. FLAT FACE FIG. 2	PAD SIZE	A	B	C	D	E	F	G	H	J	K	L	M	N	P	R UNC-2B	MOUNTING HARDWARE	
																		O-RING	SHCS
W172-12-12	W177-12-12	.75	1.69	2.56	.875	1.875	2.28	1.44	1.25	.875	1.250	.752	.752	.625	.312	.406	3/8-16	214	3/8-16X2.00
W172-16-12	W177-16-12	.75	1.69	2.56	.875	1.875	2.28	1.44	1.25	.875	1.250	.752	1.002	.750	.438	.406	3/8-16	214	3/8-16X2.00
W172-16-16	W177-16-16	1.00	1.94	2.75	1.031	2.062	2.62	1.66	1.50	1.062	1.560	1.002	1.002	.875	.438	.406	3/8-16	219	3/8-16X2.25
W172-20-16	W177-20-16	1.00	1.94	2.75	1.031	2.062	2.62	1.66	1.50	1.062	1.560	1.002	1.252	1.000	.500	.406	3/8-16	219	3/8-16X2.25
W172-20-20	W177-20-20	1.25	2.19	3.12	1.188	2.312	3.00	1.91	1.81	1.188	1.750	1.252	1.252	1.125	.500	.469	7/16-14	222	7/16-14X2.75
W172-24-20	W177-24-20	1.25	2.19	3.12	1.188	2.312	3.00	1.91	1.81	1.188	1.750	1.252	1.502	1.250	.562	.469	7/16-14	222	7/16-14X2.75
W172-24-24	W177-24-24	1.50	2.56	3.69	1.406	2.750	3.33	2.05	2.00	1.312	2.115	1.502	1.502	1.375	.562	.531	1/2-13	225	1/2-13X3.00
W172-28-24	W177-28-24	1.50	2.56	3.69	1.406	2.750	3.33	2.05	2.00	1.312	2.115	1.502	1.752	1.500	.562	.531	1/2-13	225	1/2-13X3.00
W172-32-32	W177-32-32	2.00	3.06	4.33	1.688	3.062	3.81	2.28	2.50	1.656	2.490	2.002	2.002	1.875	.625	.531	1/2-13	228	1/2-13X3.50
W172-36-32	W177-36-32	2.00	3.06	4.33	1.688	3.062	3.81	2.28	2.50	1.656	2.490	2.002	2.252	2.000	.625	.531	1/2-13	228	1/2-13X3.50