

Directional Control Valves

SECTIONAL BODY

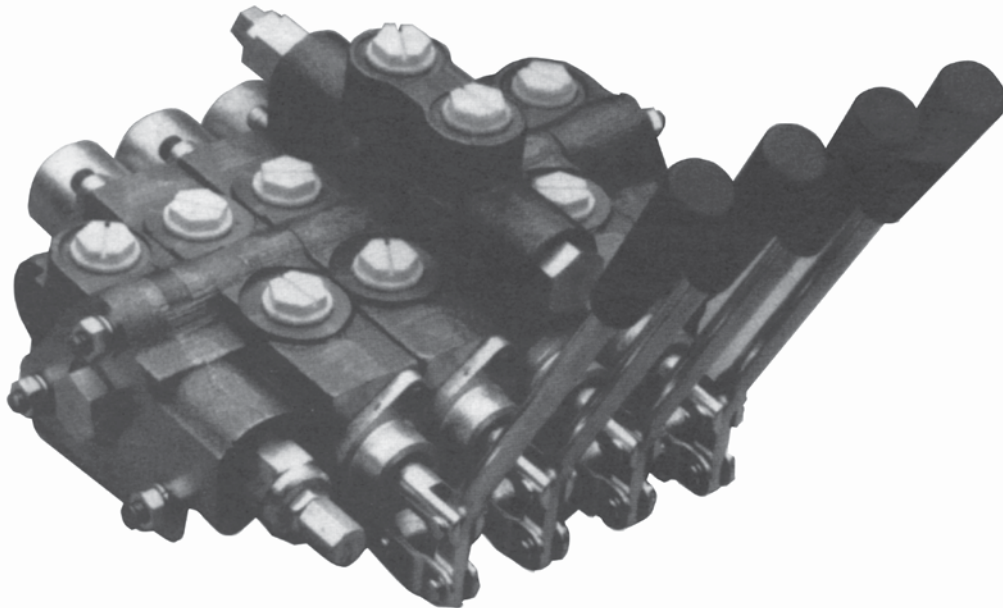

Model SV

STANDARD FEATURES

- 1-10 Sections Per Valve Bank
- Load Checks On Each Section
- Hard Chrome Plated Spools
- Compact Construction
- Enhanced Metering Section Available in both the High and Low Sections
- Differential Poppet Style Relief, Adjustable from 1500 to 3000 psi (Also available in Low Pressure Version Adjustable from 500 to 1500 psi)
- Power Beyond Capability
- Reversible Handle
- Mid-Inlet and Lock Valve Section available
- Flow Control Inlet

SPECIFICATIONS

Parallel or Series Circuit Construction Pressure Rating

Maximum Operating Pressure 3000 psi
Maximum Tank Pressure..... 500 psi

Nominal Flow Rating 12 GPM
Refer to Pressure Drop Curves.

Filtration: For general purpose valves, fluid cleanliness should meet the ISO 4406 19/17/14 level. For extended life or for pilot operated valves, the 18/16/13 fluid cleanliness level is recommended.

Foot Mounting

Maximum Operating Temp. 180°F

Weight Per Section

Inlet Section Approx 3.75 lbs.
Outlet Section Approx 3.75 lbs.
Work Section (Standard) Approx 5.50 lbs.
Work Section (High) Approx 8.00 lbs.

ORDERING INFORMATION:

The following is a listing of valve sections available from stock on a standard basis.
STANDARD SECTIONS AVAILABLE:

INLET SECTIONS ALL HAVE BOTH TOP AND SIDE INLET PORTS

PART NO. RELIEF TYPE AND SETTING

SVI21	No Relief
SVI24	Adjustable Low Pressure Relief Set at 1000 PSI
SVI15	Adjustable High Pressure Relief Set At 2000 PSI
SVI25	Adjustable High Pressure Relief Set at 2000 PSI

PORT SIZE

#10 SAE ORB (7/8-14 THD)
#10 SAE ORB (7/8-14 THD)
#8 SAE ORB (3/4-16 THD)
#10 SAE ORB (7/8-14 THD)

WORK SECTIONS ALL HAVE #8 SAE ORB (3/4-16 THD) PORTS, LOAD CHECK AND STANDARD LEVER HANDLE

PART NO. SPOOL TYPE AND ACTION

SVW1AA1	3-Way Single Acting w/ Spring Center
SVW1BA1	4-Way Double Acting w/ Spring Center (Work Ports Blocked in Neutral)
SVW1BB1	4-Way Double Acting w/ 3 Position Detent (Work Ports Blocked in Neutral)
SVW1CA1	4-Way Motor Spool w/ Spring Center (Work Ports Open to Tank in Neutral)
SVW1CB1	4-Way Motor Spool w/ 3 Position Detent (Work Ports Open to Tank in Neutral)
SVW1DD1	4-Way 4 Position Float w/ Spring Center and Float Detent
SVL1CA1	4-Way Spool w/ Spring Center (with Pilot Operated Checks on Both Work Ports)
SVM1ES1	4-Way Meter Spool w/ Spring Center (Work Ports Blocked in Neutral)

PORT RELIEF WORK SECTIONS ALL HAVE #8 SAE ORB (3/4-16 THD) PORTS, LOAD CHECK AND STANDARD LEVER HANDLE. MODELS WITH RELIEF FACTORY SET AT 2000 PSI AT 3 GPM.

PART NO. SPOOL TYPE AND ACTION

SVH1BA1AA	4-Way Double Acting w/ Spring Center
SVH1BA1GG	4-Way Double Acting w/ Spring Center
SVH1DD1AA	4-Way 4 Position Float w/ Spring Center and Float Detent
SVH1DD1BB	4-Way 4 Position Float w/ Spring Center and Float Detent
SVR1ES1AA	4-Way Meter Spool w/ Spring Center
SVR1ES1GG	4-Way Meter Spool w/ Spring Center
SVS1GA1GG	4-Way Double Acting Series w/ Spring Center
SVS1GA1AA	4-Way Double Acting Series w/ Spring Center

PORT RELIEFS

Port Relief Plugged
Adjustable 1500-3000 PSI
Port Relief Plugged
Shim Adjustable 1500-3000 PSI
Port Relief Plugged
Adjustable 1500-3000 PSI
Adjustable 1500-3000 PSI
Port Relief Plugged

OUTLET SECTIONS ALL HAVE BOTH TOP AND SIDE OUTLET PORTS

PART NO. EXHAUST OPTIONS

SVE11	Open Center Outlet w/ Conversion Plug
SVE21	Open Center Outlet w/ Conversion Plug
SVE22	Power Beyond Outlet w/ #8 SAE Beyond Port
SVE23	Closed Center Outlet
SVE26	Open Center Outlet Pressure Build-up Valve
SVE27	Power Beyond Pressure Build-up Valve

PORT SIZE

#8 SAE ORB (3/4-16 THD)
#10 SAE ORB (7/8-14 THD)
#10 SAE ORB (7/8-14 THD)
#10 SAE ORB (7/8-14 THD)
#10 SAE ORB (7/8-14 THD)
#10 SAE ORB (7/8-14 THD)

TIE ROD KITS

TIE ROD TORQUE
 150in-lbs ± 6in-lbs
 (12 1/2 ft-lbs ± 1/2)

PART NO.

660401001	1 Section*
660401002	2 Sections*
660401003	3 Sections*
660401004	4 Sections*
660401005	5 Sections*

*Number of Work Sections

PART NO.

660401006	6 Sections*
660401007	7 Sections*
660401008	8 Sections*
660401009	9 Sections*
660401010	10 Sections*

SPECIAL INLET AND OUTLET SECTIONS AVAILABLE: Sections other than standard models listed can be made to order. Use order code Matrix below to generate a model number that meets your requirements. If you prefer, contact your Sales Representative with your specific requirements and a model number will be assigned for you. This model number can be used for future orders. A minimum order quantity will apply to special valves. Please consult Sales Representative.

INLET SECTIONS

All inlet sections have top and side inlets.

S V I X X - X X X X

PORT SIZE

- #8 SAE ORB (3/4-16 THD)
- #10 SAE ORB (7/8-14 THD)

RELIEF SETTING (in PSI)

- #### RELIEF OPTION
- No Relief Plug
 - Adj. Low Pressure 500-1500 PSI
 - Adj. High Pressure 1500-3000 PSI
 - Plastic Plug in relief cavity. Use only when cartridge is to be installed at a later date.

OUTLET SECTION

All outlet sections have top and side outlets.

S V E X X

PORT SIZE

- #8 SAE ORB (3/4-16 THD)
- #10 SAE ORB (7/8-14 THD)

EXHAUST OPTION

- Std. Open Center Outlet w/Conversion Plug
- Power Beyond Outlet w/#8 SAE Beyond Port
- Closed Center Outlet⁰
- Open Center Outlet Pressure Build-up
- Power Beyond Pressure Build-up #8 SAE Beyond Port

⁰ Often used with no relief. Review application

VALVE ASSEMBLIES

The Model SV sectional body directional control valve can be ordered as separate sections or as a complete factory tested assembly. This will need to be specified with each order. An assembly number will be assigned at the time of the order. This assembly number can then be used for future orders.

ASSEMBLY MODEL NUMBER SVA-XXXX

XXXX = Sequence of Numbers. This number will be assigned to final valve to be assembled and tested at the factory. Each new order or quote will be assigned a new assembly model number. Please use quotation sheet at the end of SV section.

SPECIAL WORK SECTIONS AVAILABLE: Work Sections other than standard models listed can be made to order. Use order code Matrix below to generate a model number that meets your requirements. If you prefer, contact your Sales Representative with your specific requirements and a model number will be assigned for you. This model number can be used for future orders. A minimum order quantity will apply to special valves. Please consult Sales Representative.

WORK SECTIONS

SECTION TYPE

- W-Std. Work Section
- M-Metering Work Section²
- L-Work Section with Double P.O. Checks¹
- F-Fine Metering³

PORT SIZE

- 1. #8 SAE ORB (3/4-16 THD)
- 2. #6 SAE ORB (9/16-18 THD)

SPOOL TYPE

- A-3-Way 3-Position
- B-4-Way 3-Position
- C-4-Way 3 Position Motor
- D-4-Way 4 Position Float
- E-4-Way 3 Position Metering (SVM only)
- F-3-Way 3 Position Metering (SVM only)
- J-4-Way 3 Position Fine Metering (SVF only)
- 1. Lock Valve Section available only with Spool Option C.
- 2. Metering Section available only with Spool Options E or F.
- 3. Fine Metering available only with Spool Options J.

S V X X X X X

HANDLE OPTION

- 1. Standard Lever Handle
- 2. Less Handle Only
- 3. Less Complete Handle Assembly
- 4. Adjustable Handle
- 5. Tang Spool End Only
- 6. Clevis Spool End Only
- 7. Vertical Handle
- 8. Straight Handle
- 9. Blank for Optional Joystick Handle
- 11. Enclosed Handle
- 12. Extended Enclosed Handle

SPOOL ACTION

- A-Spring Center (SVW & SVL only)
- B-3 Position Detent
- C-Friction Detent
- D-Spring Center w/Float Detent (SVW only)
- E-Light Spring Center
- F-2 Position Detent Neutral and Out (No IN Position)
- G-2 Position (Center and Spool Out) - Spring Loaded to Spool Out (Pressure to B Port) Position
- H-2 Position (Center and Spool In)-Spring Loaded to Spool In (Pressure to A Port) Position
- J-S/C with MicroSwitch Bracket 2-Position (MicroSwitch not provided)
- K-S/C with MicroSwitch Bracket 1-Position (MicroSwitch not provided) (activates on spool out only)
- M-Spring Center Detent In
- N-Spring Center Detent Out
- R-Spring Center Pneumatic Actuator
- S-Spring Center (SVM & SVF)

PORT RELIEF WORK SECTIONS

SECTION TYPE

- H-Port Relief Section
- R-Port Relief Metering Section²
- S-Series Circuit Port Relief Section
- G-Port Relief Fine Metering Section³

PORT SIZE

- 1.#8 SAE ORB (3/4-16 THD)
- 2.#6 SAE ORB (9/16-18 THD)

SPOOL TYPE

- A-3-Way 3-Position
- B-4-Way 3-Position
- C-4-Way 3 Position Motor
- D-4-Way 4 Position Float
- E-4-Way 3 Position Metering (SVR only)
- F-3-Way 3 Position Metering (SVR only)
- G-4-Way 3 Position Series (SVS only)
- H-4-Way 3 Position Motor Series (SVS only)
- J- 4-Way 3 Position Fine Metering (SVG only)

SPOOL ACTION

- A-Spring Center (SVH & SVS only)
- B- 3 Position Detent
- C-Friction Detent
- D- Spring Center w/ Float Detent (SVH only)
- E-Light Spring Center
- F-2 Position Detent Neutral and Out (No IN Position)
- J-S/C with Micro Switch Bracket 2-Position*
- K-S/C with MicroSwitch Bracket 1-Position*
- M-Spring Center Detent In
- N-Spring Center Detent Out
- R-Spring Center Pneumatic Actuator
- S-Spring Center (SVR & SVG)

*MicroSwitch not provided

HANDLE OPTION

- 1. Standard Lever Handle
- 2. Less Handle Only
- 3. Less Complete Handle Assembly
- 4. Adjustable Handle
- 5. Tang Spool End Only
- 6. Clevis Spool End Only
- 7. Vertical Handle
- 9. Blank for Optional Joystick Handle
- 12. Extended Enclosed Handle

S V X X X X X X X

PORT RELIEF "B" OPTION

- A-Relief Cavity Plugged
- B-Non-Adjustable Direct Acting Relief 1500-3000 PSI
- C-Non-Adjustable Direct Acting Relief 500-1500 PSI
- D-Anti-Cavitation Check
- E-Adjustable Combination Port Relief/Anti-Cavitation Check 1000-2500 PSI***
- F-Non-Adjustable Combination Port Relief/Anti-Cavitation Check 1000-2500 PSI***
- G-Adjustable Direct Acting Relief 1500-3000 PSI
- H-Adjustable Direct Acting Relief 500-1500 PSI

PORT RELIEF "A" OPTION

- A-Relief Cavity Plugged
- B-Non-Adjustable Direct Acting Relief 1500-3000 PSI
- C-Non-Adjustable Direct Acting Relief 500-1500 PSI
- D-Anti-Cavitation Check
- **E-Adjustable Combination Port Relief/Anti-Cavitation Check 1000-2500 PSI***
- F-Non-Adjustable Combination Port Relief/Anti-Cavitation Check 1000-2500 PSI***
- **G-Adjustable Direct Acting Relief 1500-3000 PSI
- **H-Adjustable Direct Acting Relief 500-1500 PSI
- ** Cannot be used on work sections with float option due to interference with handle.
- *** Do not use in applications that require low work port leakage. Max allowable leakage 5 in³/min @1000 psi.

For Work Port Relief Settings Other Than Standard SVH1BA1GG-18-25

B PORT RELIEF PRESSURE IN HUNDREDS
EXAMPLE: 25=2500 PSI at 3 GPM
All Port Reliefs set at 3 GPM

A PORT RELIEF PRESSURE IN HUNDREDS
EXAMPLE: 18=1800 PSI at 3 GPM
All Port Reliefs set at 3 GPM

CUSTOM SECTION: For OEM application custom sections can often be designed to meet your specifications. Special handles, spool, and spool actions are often easily made because of the SV valve's flexible design. Consult your sales representative with your specifications.

FIELD CONVERSION KITS, REPAIR KITS AND RELIEF CARTRIDGES

SPOOL ATTACHMENT KITS

- 660180001 Spring Center Kit (except SVM)
- 660180002 3 Position Detent Kit
- 660180003 Friction Detent Kit
- 660180051 Float Detent Kit
- 660180036 Spring Center Detent In
- 660180037 Spring Center Detent Out
- 660180015 S/C w/Micro-Switch, 2 Position*
- 660180016 S/C w/Micro-Switch, 1 Position*

HANDLE KITS

- 660180011 Std. Handle Kit
- 660180032 Clevis Sub-Assy
- 660180005 Complete Handle Kit
- 660180031 Pin Kit
- 660180026 Vertical Handle Kit
- 660180028 Straight Handle Kit
- 660180007 Complete Adjustable Handle Kit

*Bracket only, Micro-Switch is not provided.

- 660180006 Adjustable Handle Kit
- 660180055 Joystick Handle Kit Less Handle
- 660180033 Bent Joystick Handle Kit
- 660180017 Straight Joystick Handle Kit
- 660180018 Offset Joystick Handle Kit

SEAL KITS

- 660580001 SVW/SVM Replacement Seal Kit
- 660580002 Inlet Seal Kit
- 660580003 Outlet Seal Kit
- 660580004 Between Section Seal Kit
- 660580010 SVH/SVR Replacement Seal Kit
- 660580009 SVL Replacement Seal Kit
- 660580011 SVS Replacement Seal Kit

PORT RELIEFS

- 660280004 Port Relief Plug
- 660280003 Shim Adj. Port Relief 1500-3000 PSI
- 660280010 Shim Adj. Port Relief 500-1500 PSI
- 660280012 Adj. Combination Port Relief/Anti-Cav Check 1000-2500 PSI

- 660280008 Shim Adj. Combination Port Relief/Anti-Cav Check 1000-2500 PSI
- 660280005 Anti-Cavitation Check
- 660280009 Adj. Port Relief 1500-3000 PSI
- 660280011 Adj. Port Relief 500-1500 PSI
- 672000101 .015 SHIM
- 672000102 .033 SHIM
- 672000103 .060 SHIM

INLET RELIEFS

- 660250006 Inlet Relief Plug
- 660250003 Low Pressure Inlet Relief
- 660250002 High Pressure Inlet Relief

OUTLET CARTRIDGES

- 200400030 Open Center Plug
- 660280001 #8 SAE Power Beyond Cart.
- 660280002 Closed Center Plug
- 660280018 Open Center Build-Up Cart.
- 660280019 Power Beyond Build-Up Cart.

MISC. KITS

- 660180052 Load Check Kit

PERFORMANCE CURVES

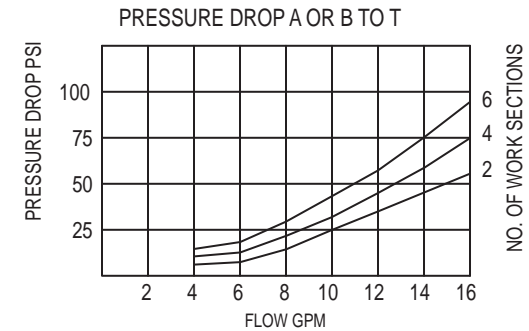
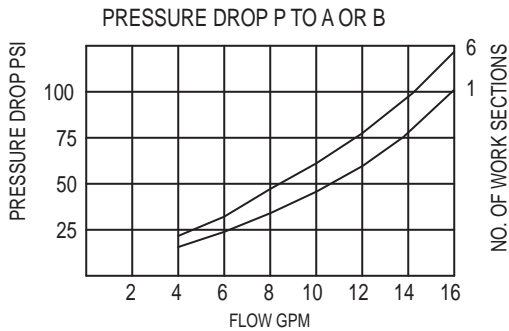
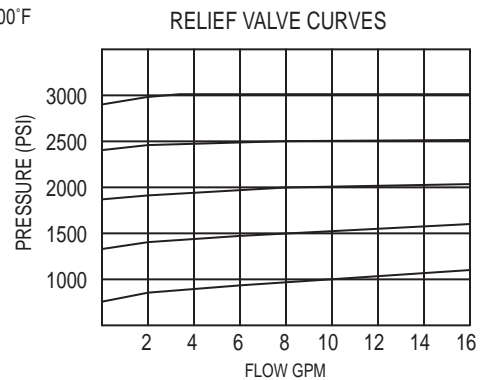
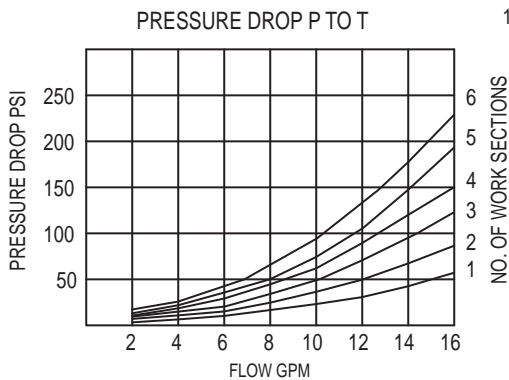

SVS SERIES SECTION TEST DATA

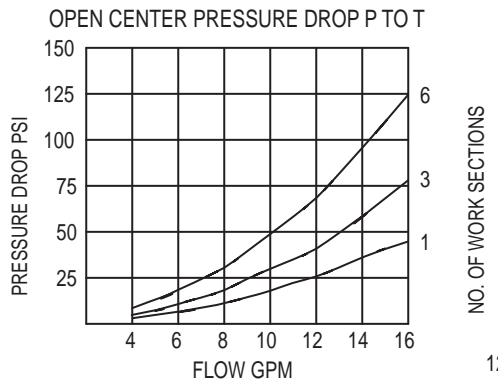

120 SUS OIL AT 100°F

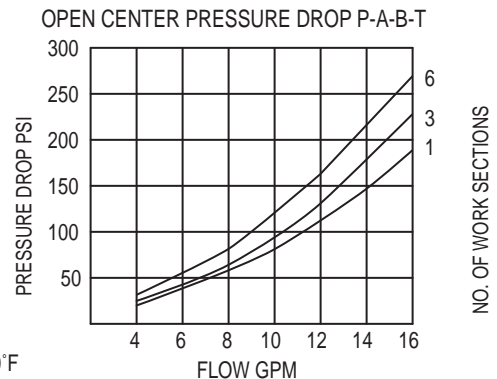

DIMENSIONAL DATA

WORK SECTIONS

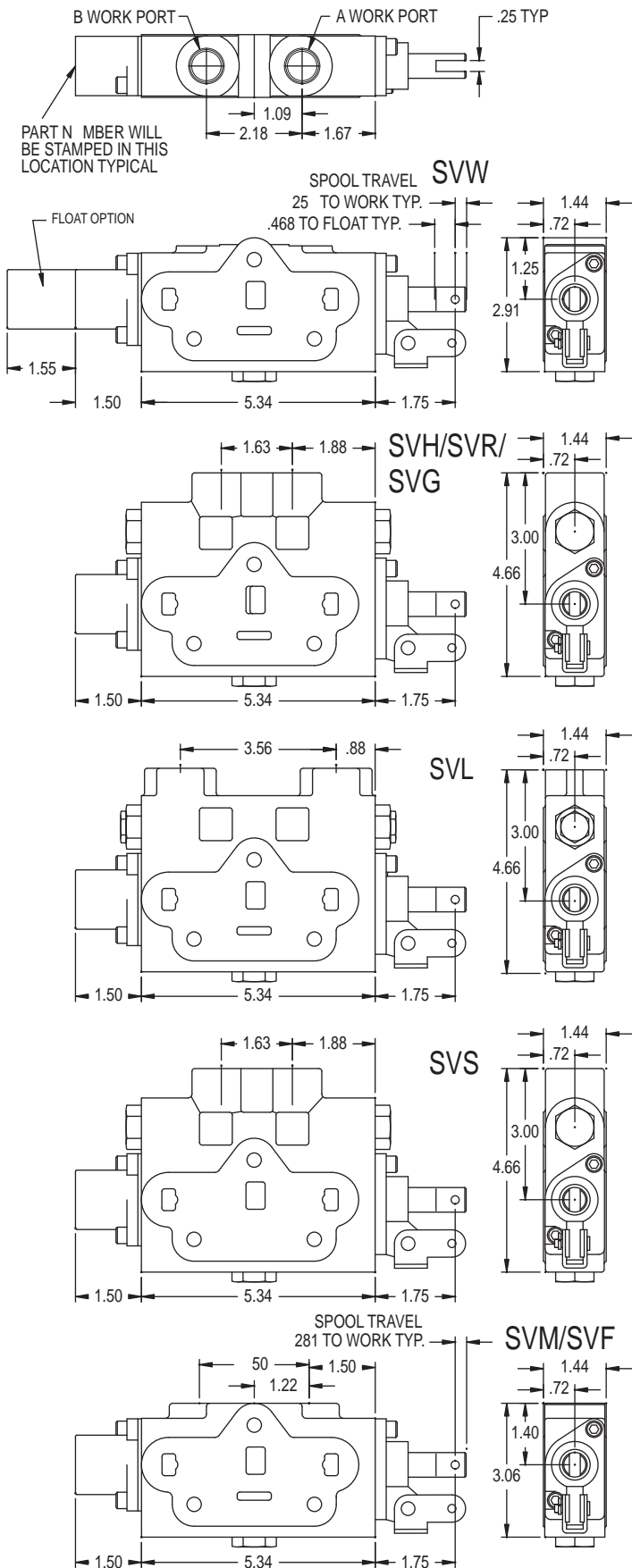

OUTLET COVER

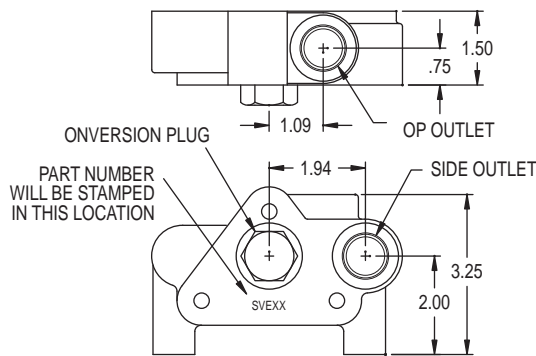

INLET COVER

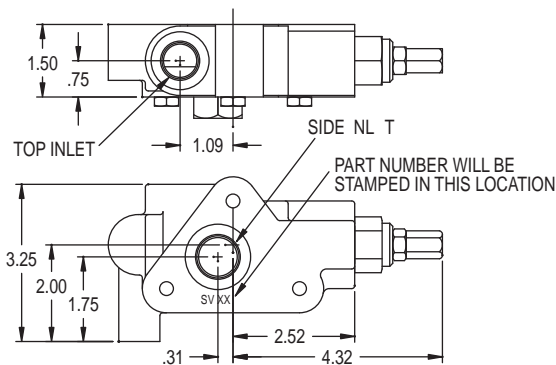

BOTTOM VIEW OF MOUNTING DIMENSIONS

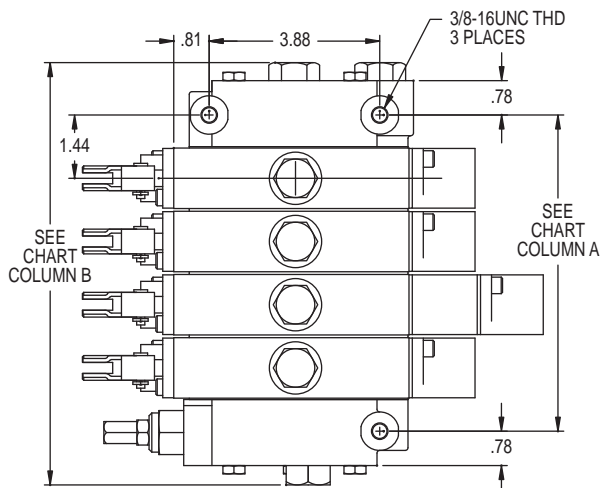

Number of Work Sections "A" "B**"

Number of Work Sections	"A"	"B**"
1	2.875	5.875
2	4.312	7.312
3	5.750	8.750
4	7.187	10.187
5	8.625	11.625
6	10.062	13.062
7	11.500	14.500
8	12.937	15.937
9	14.375	17.375
10	15.812	18.812

*With #10 plug in inlet & power beyond in outlet.

VALVES

TYPICAL STACK DIMENSIONAL DATA

THE ROD TORQUE
 150 in-lbs +6 in - lbs
 (12 1/2 ft - lbs +1/2)

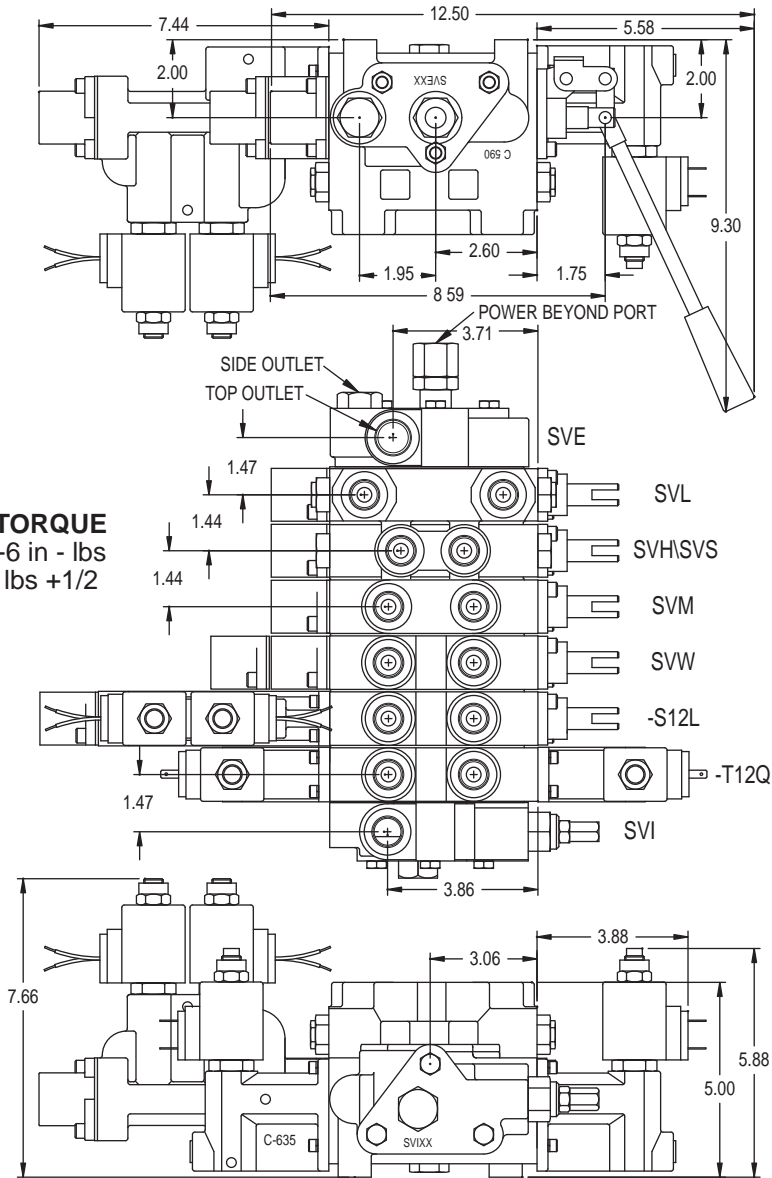

ENCLOSED HANDLE, OPTIONS 11 AND 12

Durable die cast metal housing. Weather and oil resistant rubber boot. Reversible handle can be mounted in either a vertical or horizontal position. The extended handle option provides the necessary clearance for work port relief and lock cartridges. The extended handle option can also be used on the SVW and SVM, work sections when it is desired to keep handles aligned in an assembly with both low and high sections.

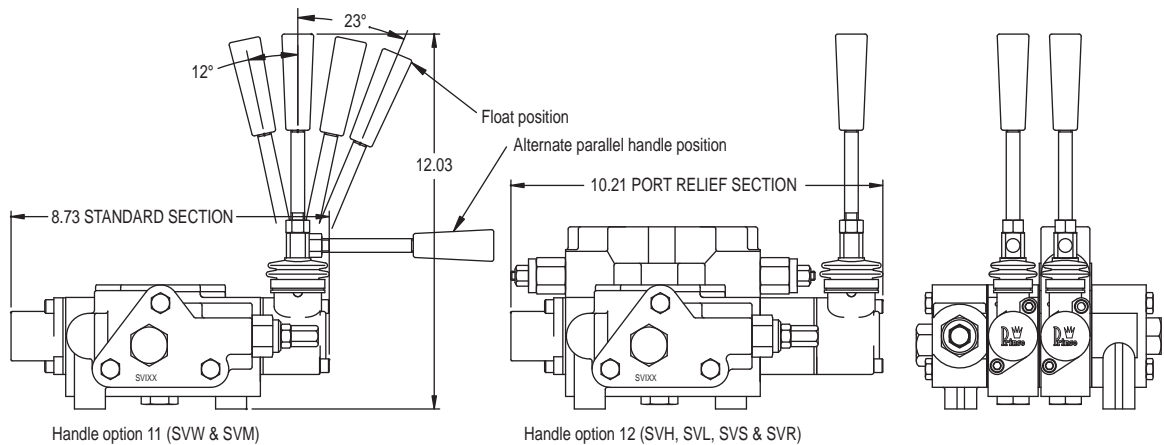

PARALLEL CIRCUIT SVW, SVM, SVF, SVH, SVR, SVG AND SVL WORK SECTIONS

Parallel circuit sections are by far the most common. The SVW, SVM, SVF, SVH, SVR, SVG and SVL are all of parallel circuit construction. They can be combined together in any order in an assembly. When any one of the spools is shifted, it blocks off the open center passage through the valve. The oil then flows into the parallel circuit core making oil available to all spools. If more than one spool is fully shifted, the oil will go to the spool with the lowest pressure requirements. However, it is possible to meter the flow to the spool with the least load and provide flow to two unequal loads.

ENHANCED METERING SECTIONS

The SVM, SVF, SVR and SVG sections have metering notches machined into the spool to allow for better "feathering" of a load. The spool travel for these sections is also a little longer at .281" vs. .250" for the standard sections. In addition to the metering notches in the spool, the lands in the SVF and SVG bodies have been machined to give more precise control over the flow. The metering notches in the SVF and SVG have been optimized for flows of 10 gpm or less. For enhanced metering on higher flows, it is recommended that the SVM or SVR be used.

LOCK SECTIONS

The SVL section combines both a 4-way directional valve and a double pilot operated check valve. This provides very low leakage when the spool is in neutral. When the spool is shifted, oil is directed through a work port check to the cylinder. Pressure on the work port applies pressure to the shuttle spool, opening the opposite check valve and allowing oil to return into the valve. Depending on load pressures, the metering of the spool may be affected. In some cases a one way restrictor in a work port may be beneficial.

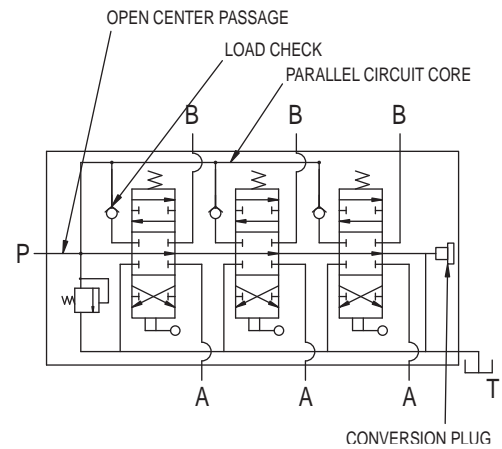

SERIES CIRCUIT SVS WORK SECTIONS

A series circuit valve is most commonly used to control more than one hydraulic component simultaneously. The entire circuit flow is available to each valve section that is actuated. In a two spool series valve with both spools actuated, the oil flows from the inlet to the work port of the first section. The return flow of the first section is directed to the open center core of the second section. (In a parallel valve the return oil from the work port is directed to the tank core.) From the open center core of the second section, the oil flows to the work port with the return oil going to the outlet. In a series circuit valve, the summation of the pressures required for each work section will equal the total pressure required for the circuit. The total pressure required must not exceed the system relief setting or the pump pressure rating. It is not required to have a SV Series section as the last section, unless series flow is required to a downstream valve. In this application, a power beyond plug must be used in the outlet section.

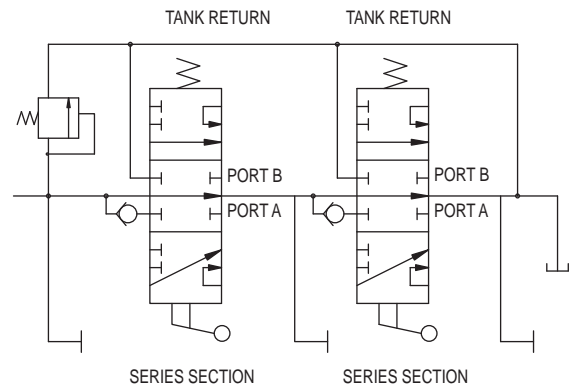

COMBINED SERIES / PARALLEL CIRCUITS

The SV Series circuit valve sections may be stacked with SV parallel circuit valve sections. This allows both series and parallel control in the same valve assembly.

In the valve assembly shown below, the first, third and fourth sections are parallel. The second section is series. The first parallel section has priority over all downstream valves. When the spool of the first parallel section is actuated, the return oil from the work port is directed to the tank core, thus oil flow to downstream sections is cut off. The second and third sections are in series with each other as is the second and fourth sections. The third and fourth sections are in parallel with each other.

SERIES MOTOR SPOOL

The SV Series Motor Spool provides control of reversible hydraulic motors. Both work ports are connected to the open center core in the neutral position. It should be noted that in the neutral position, the work ports will be equally pressurized to the same pressure that is required of any downstream valve sections and that a work port relief in the section will also limit the pressure of any other sections in the valve. The series motor spool should not be used to control a hydraulic cylinder as unwanted cylinder drift may occur in the neutral position.

CLOSED CENTER APPLICATIONS

The SV Series Circuit Valve sections cannot be used in a closed center valve assembly.

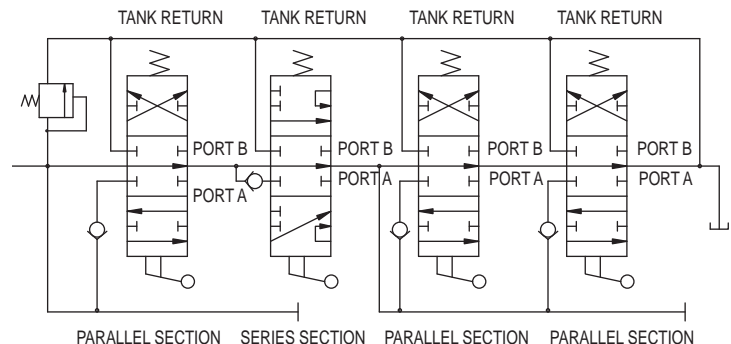

WORK SECTIONS

SPOOL ATTACHMENT OPTION B
3 POSITION DETENT

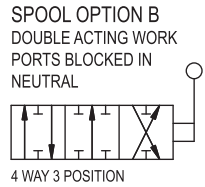
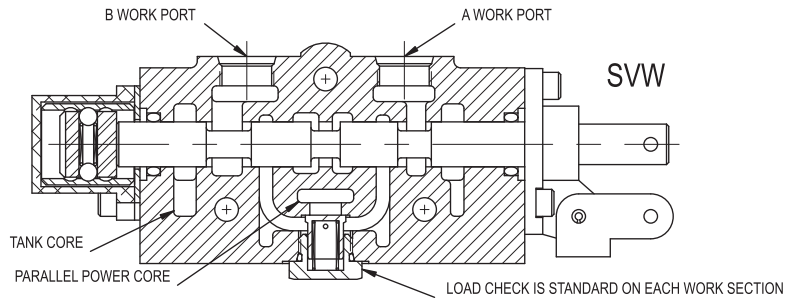

SPOOL ATTACHMENT OPTION S
SPRING CENTER (FINE METERING)

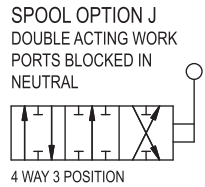
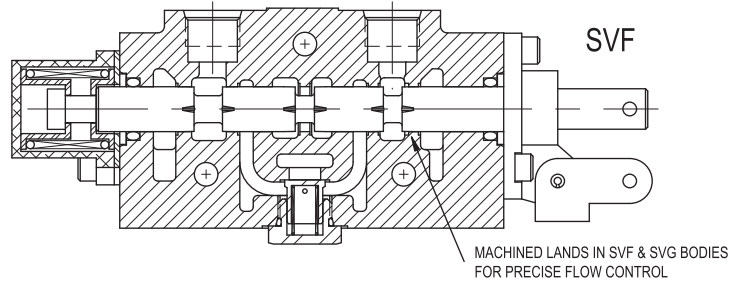

SPOOL ATTACHMENT OPTION A
SPRING CENTER

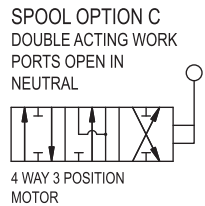
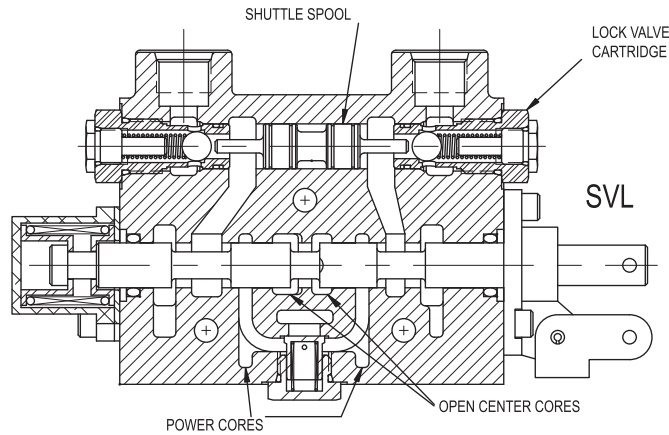

ADJUSTABLE DIRECT
ACTING RELIEF OPTION 'G'

SPOOL ATTACHMENT OPTION D
SPRING CENTER W/FLOAT DETENT

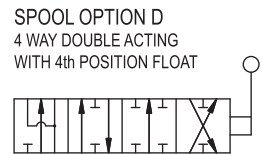
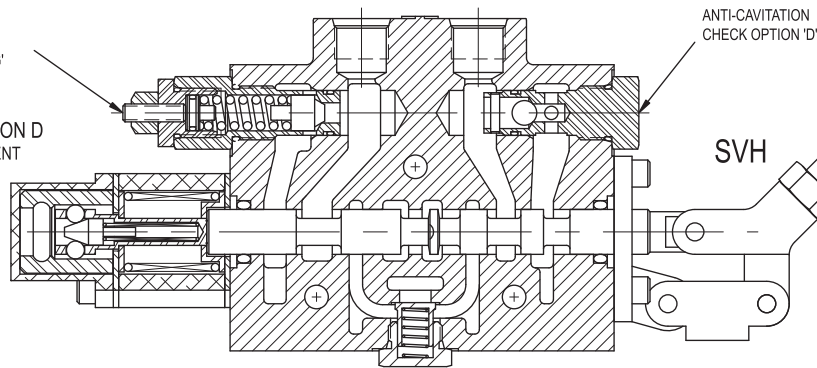

SV WORK PORT RELIEF

SV WORK PORT RELIEFS, OPTION B, C, G, & H CAN BE ORDERED PRETESTED. USE ORDER CODE AT RIGHT

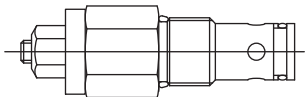

PR	-	0	-	-
MODEL NUMBER	PORT SIZE	RELIEF TYPE	PRESSURE SETTING	
	0 CARTRIDGE ONLY	H- ADJUSTABLE 1500-3000 PSI L- ADJUSTABLE 500-1500 PSI NH- NON-ADJUSTABLE 1500-3000 PSI NL- NON-ADJUSTABLE 500-1500 PSI	SPECIFY RELIEF PRESSURE. LEAVE BLANK FOR STANDARD SETTINGS. STANDARD SETTING: 2000 PSI for H and NH 1000 PSI for L and NL	

VALVES

SV INLET RELIEF OPTIONS

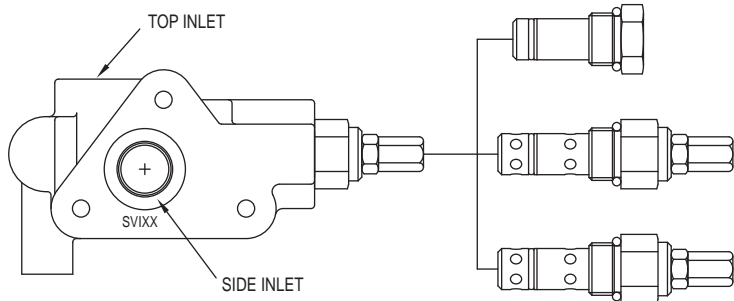

OPTION 1 NO RELIEF

This option provides no built in relief. This is used when a relief is provided elsewhere in the system or in a closed center application. This plug can be replaced with a relief cartridge at a later date.

OPTION 4 LOW PRESSURE ADJUSTABLE RELIEF

This option provides for a differential poppet relief adjustable from 500-1500 PSI. Set at 1000 PSI @ 10 GPM.

OPTION 5 HIGH PRESSURE ADJUSTABLE RELIEF

This option provides for a differential poppet relief adjustable from 1500-3000 PSI. Set at 2000 PSI @ 10 GPM. The differential poppet relief provides smooth quiet operation with high cracking pressure.

RELIEF CARTRIDGES CAN BE ORDERED PRETESTED SEE RV-OX RELIEF, PAGE V65.

SV OUTLET COVER OPTIONS

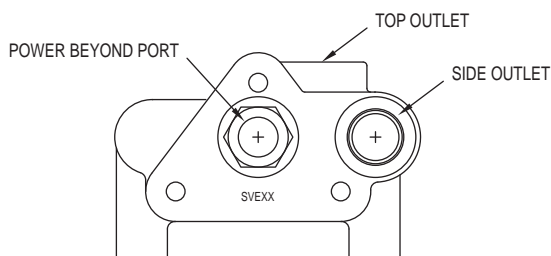

OPTION 3 CLOSED CENTER OUTLET

This option provides for closed center operation. This is typically used with a variable displacement pressure compensated pump or in a system with an unloading valve. When the spools are in neutral the inlet port is blocked. Closed center can also be accomplished by plugging the power beyond port of option 2.

PLEASE NOTE that this closed center option does not provide for the drain off of standby spool leakage. This can allow a very small amount of oil to enter the work ports when in neutral.

OPTION 1 STANDARD OPEN CENTER OUTLET WITH CONVERSION PLUG

This is the standard outlet option. This option allows for conversion in the field for power beyond or closed center applications. When spools are in neutral the inlet is unloaded to tank.

OPTION 6 OPEN CENTER OUTLET PRESSURE BUILD-UP VALVE FOR SOLENOID OPTION

This option directs oil from open center core thru pressure build-up valve and then to tank. See solenoid section for description of operation.

OPTION 2 POWER BEYOND OUTLET WITH #8 SAE BEYOND PORT

This option provides for a high pressure power beyond port. This would be used if a valve is to be added down stream. THE OUTLET PORT MUST STILL BE CONNECTED TO TANK. When spools are in neutral the inlet is connected to the power beyond port.

OPTION 7 POWER BEYOND PRESSURE BUILD-UP VALVE FOR SOLENOID OPTION

This option directs oil from inlet thru pressure build-up valve and then downstream. This pressure build-up valve provides a #8 SAE power beyond port. The outlet must be connected to tank.

VALVES

SV MID-INLET SECTION

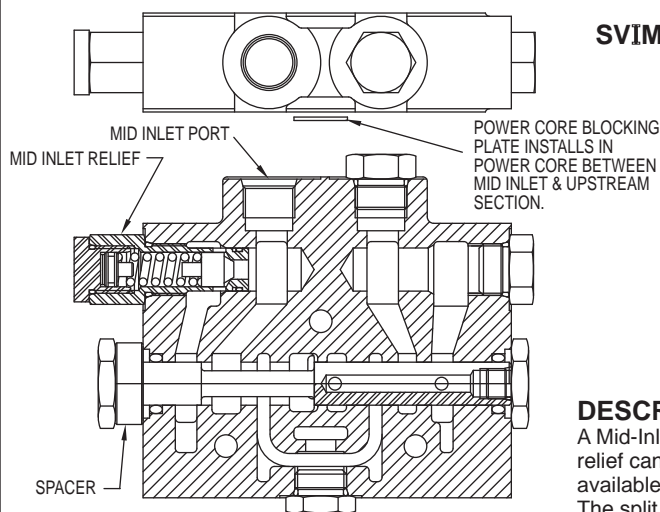

SPLIT MID-INLET SHOWN CAN BE CONVERTED TO COMBINED MID-INLET BY MOVING SPACER TO OPPOSITE END

SVIM 1 X X - X X X X

Last Four Digits Specify
A Non-Standard Relief Pressure.
When blank, refer to standard setting

- 1-No Relief
- 2-SHIM Adjustable 500-1500 PSI Std. Setting 1000 PSI @ 10GPM
- 3-SHIM Adjustable 1500-3000 PSI Std. Setting 2000 PSI @ 10 GPM
- 4-Adjustable 500-1500 PSI Std. Setting 1000 PSI @ 10 GPM
- 5-Adjustable 1500-3000 PSI Std. Setting 2000 PSI @ 10 GPM

C-Combined Flow Mid-Inlet
S-Split Flow Mid-Inlet (not available after a series section)
See Section View at left. Note
Location of Spacer, Part Number 671200035

1. Port Size #8 SAE ORB (3/4-16 THD)

DESCRIPTION:

A Mid-Inlet provides an inlet port for a second pump mid stream in the valve stack. A relief can be provided in this section. With the combined flow the flow from both pumps is available to the downstream sections when all the work sections upstream are in neutral. The split flow completely separates the two pump flows. The common tank passage is all that is shared between the two pump flows. **Note:** Split flow mid inlet is not available when used after a series section and the core block plate is not used after a series section.

SV FLOW CONTROL INLET SECTION

PORT SIZE ————— SVIFXXX

1- Side and End Inlet #10 SAE ORB
2- Side and End Inlet #10 SAE ORB, with #8 SAE ORB External EF Circuit

RELIEF VALVE —————

1- No Relief
2- Direct acting non-adjustable 500-1500 psi set at 1000 psi*
3- Direct acting non-adjustable 1500-3000 psi set at 2000 psi*
4- Direct acting adjustable 500-1500 psi set at 1000 psi*
5- Direct acting adjustable 1500-3000 psi set at 2000 psi*
*for other settings please specify, i.e. SVIF15P12Q-2700 is set at 2700 psi

SOLENOID OPTION
Omit for Flow Control Option M
12Q-12VDC Double Spade Coil
24Q-24VDC Double Spade Coil
12H-12VDC DIN 43650 Coil
24H - 24VDC DIN 43650 Coil
12L-12VDC Double Lead Wire Coil
24L - 24VDC Double Lead Wire Coil
12W - 12VDC Double Lead Wire w/ Weatherpak Connector Coil
24W - 24VDC Double Lead Wire w/ Weatherpak Connector Coil

FLOW CONTROL OPTION
M- Manual Flow Control
P- Electro-Proportional
U- Solenoid Unloading

The SVIF Flow Control Inlet is interchangeable with the standard SV inlet section.

FLOW CONTROL OPTIONS:
P OPTION incorporates a solenoid operated, electrically variable pressure-compensated flow control cartridge. With the solenoid de-energized, all of the inlet flow is diverted to the tank core/EF port. By increasing the current through the solenoid, the flow directed to the power core and downstream sections will be proportionally increased, (the maximum rating of the cartridge is 16 gpm at 1500 mA) Control current is normally provided via a controller card providing, a PWM signal.

U OPTION incorporates a solenoid operated, unloader cartridge. With the solenoid de-energized, all of the inlet flow is diverted to the tank core/EF port. With the solenoid energized all the inlet flow is directed to the power core and downstream sections.

M OPTION incorporates a manually operated pressure-compensated flow control cartridge. With the control knob turned fully in (clockwise), all of the inlet flow is diverted to the tank core/EF port. By turning the flow control knob counter clockwise, the inlet flow directed to the power core and downstream sections is proportionally increased. Approximately 5 revolutions varies flow from no flow to full flow,

PORT OPTION 2 The flow being directed to the tank core/EF port may be utilized by a second circuit by inserting a 1/4 pipe plug into the tank core passage on the seal side of the casting and then connecting the EF port to the second circuit.

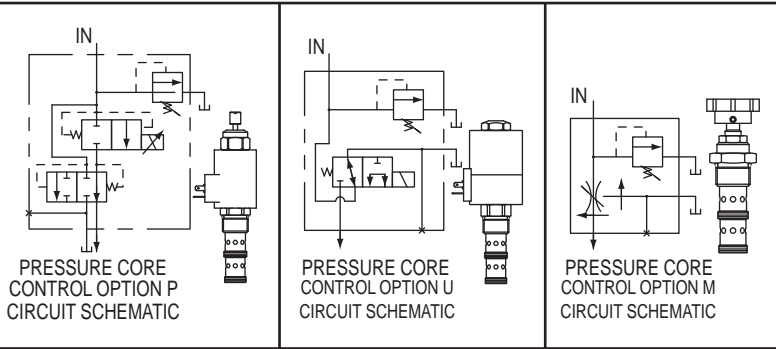
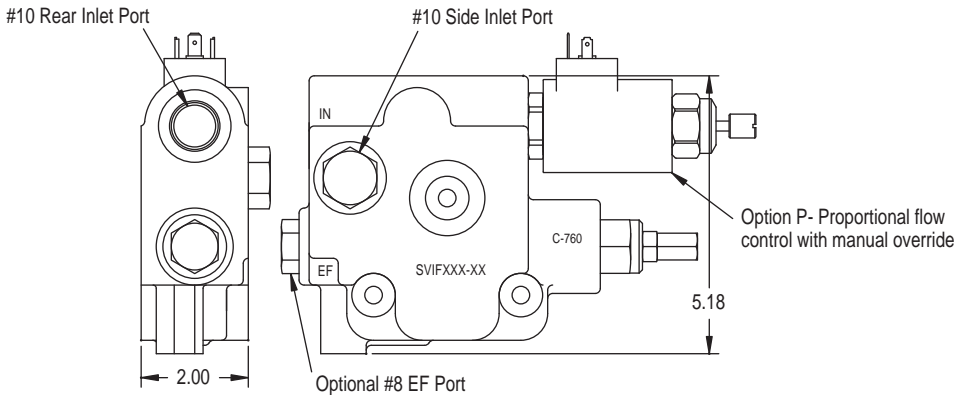

PROPORTIONAL CONTROLLER BOX (for use with SVIFP flow control inlet), PART NO. 67130048

The proportional controller box is used to provide an adjustable electrical signal to a proportional solenoid on the SVIFP inlet. Once the dial is set, the regulated flow through the valve should remain approximately constant regardless of pressure. Within the operating range, flow varies approximately linearly with dial rotation.

CONNECTIONS AND OPERATION:

- *Connect leads to the power supply and solenoid. Power supply should be between 9 and 32 VDC.
- *With the power off, the inlet flow is directed to the tank (or excess flow port).
- *To provide power to the control, move the power switch to ON. (Green LED is ON when control is powered).
- *Minimum flow is directed into the valve when 0 on the dial is aligned with the center mark. Maximum flow is directed into the valve when 10 on the dial is aligned with the center mark.
- *Clockwise rotation increases flow.
- *Typically, no adjustments are needed for operation, (I-min and I-max pots are preset for the normal maximum and minimum flows)

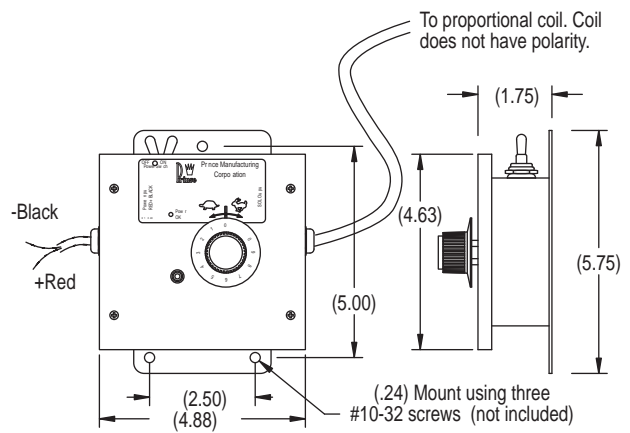

Control comes with 6 ft of cable for power leads and 6 ft of cable for coil leads. Control box protection rating is IP67.

VALVES

JOYSTICK HANDLE FOR MODEL SV STACK VALVE

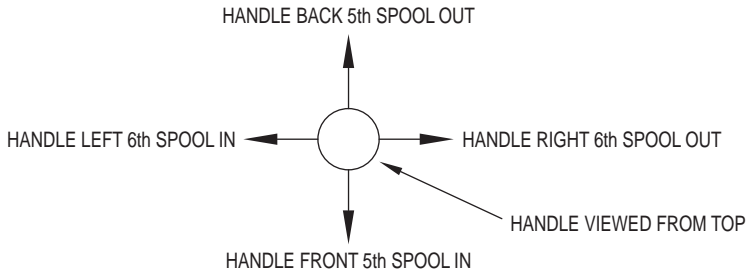

This is a special handle for the model SV stack valve that allows the spools of two adjacent sections to be operated by one common handle. The spools can be operated independently or simultaneously depending on handle movement. The option is normally used on spring center to neutral sections, but can also be used on other sections such as float sections. This handle is normally installed on valves assembled at the factory but can be installed on work sections that have handle option 3 or 9. The drawing at right shows two joysticks with offset handles installed on a six section valve. When two joysticks are installed on the same valve assembly it is recommended that there be two standard sections between them to prevent handle interference. A two section spacer is available, part no. 660380002.

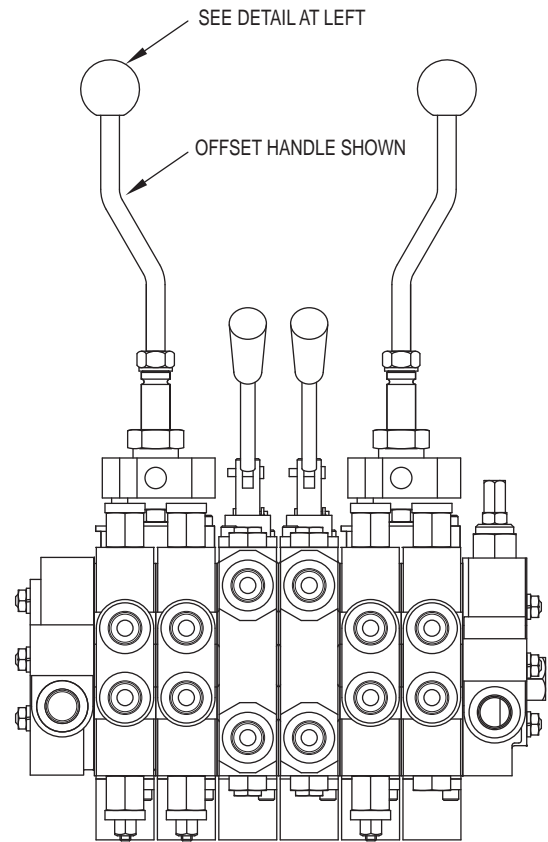

Please refer to these part numbers and state which sections the handle is to be installed on when ordering a valve assembly. This handle can be installed in the field to work sections with handle option 3 (no handle).

- JOYSTICK ASSEMBLY W/STRAIGHT HANDLE:
ASSEMBLED ON VALVE SVJS
KIT 660180017
- JOYSTICK ASSEMBLY W/OFFSET HANDLE:
ASSEMBLED ON VALVE SVJO
KIT 660180018
- JOYSTICK ASSEMBLY W/BENT HANDLE:
ASSEMBLED ON VALVE SVJB
KIT 660180033

A molded rubber boot (671300011) is available for the joystick.

ONE WAY WORK PORT RESTRICTOR FOR SVH, SVM, SVR, & SVL WORK SECTIONS

This restrictor will restrict oil in one direction and allow free flow in the opposite direction. This restrictor consists of an orifice plate that simply drops into the #8 SAE work port of a SVH, SVM, SVR, & SVL work section.

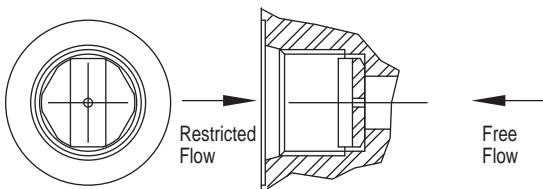

ORDERING INFORMATION

HEX BRASS RESTRICTOR	
#6 SAE 9/16-18 670806XXX	#8 SAE 3/4-16 670805XXX
SQUARE STEEL RESTRICTOR CONICAL SPRING	661181XXX

The last three digits of part number are the orifice size in thousandths of an inch. **EXAMPLE:**

#6 SAE 9/16-18THD	#8 SAE 3/4-16THD	
670806062	670805062	.062 ORIFICE
670806125	670805125	.125 ORIFICE
670806000	670805000	NO ORIFICE

ONE WAY WORK PORT RESTRICTOR FOR SVW WORK SECTIONS

This restrictor will restrict oil in one direction and allow free flow in the opposite direction. This restrictor consists of the orifice plate as described at left and an adapter fitting that allow use in the standard SVW #8 SAE work port.

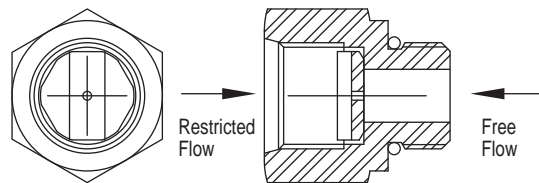

ORDERING INFORMATION

ADAPTER W/HEX BRASS RESTRICTOR	
#6 SAE 9/16-18 661280XXX	#8 SAE 3/4-16 661180XXX
ADAPTER WITH SQUARE STEEL RESTRICTOR AND CONICAL SPRING	661182XXX

The last three digits of part number are the orifice size in thousandths of an inch. **EXAMPLE:**

#6 SAE 9/16-18THD	#8 SAE 3/4-16THD	
661280062	661180062	.062 ORIFICE
661280125	661180125	.125 ORIFICE
661280000	661180000	NO ORIFICE