

Direct-acting sequence valve with reverse flow check

Capacity:
60 gpm (240
L/min.)

Functional Group:

Products : Cartridges : Sequence : 3 Port : Direct Acting with Reverse Flow
Check

Model:
SCGA-LDN

Product Description

Direct-acting sequence valves with reverse-flow check will supply a secondary circuit with flow once the pressure at the inlet (port 1) has exceeded the valve setting. Additionally, these valves incorporate an integral check valve to provide reverse flow from port 2 (sequence) to port 1 (inlet). The pressure setting of a sequence valve controls the pressure at port 1 relative to the pressure at the drain (port 3).

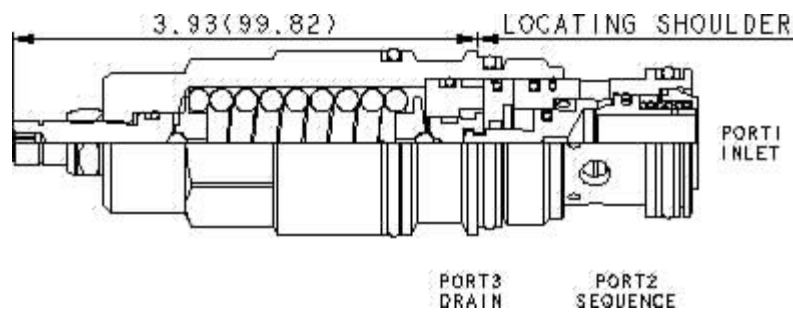
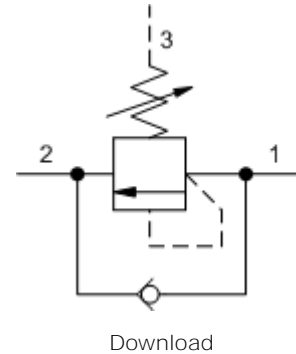

Technical Features

- All 3 port sequence cartridges are physically and functionally interchangeable (i.e. same flow path, same cavity for a given frame size).
- Although this is a zero pilot flow valve, port 3 (drain) must be connected to maintain a pressure reference in the control chamber. If port 3 is blocked, reciprocating seal weepage will cause the valve to malfunction.
- Pressure at port 3 is directly additive to the valve setting at a 1:1 ratio and should not exceed 5000 psi (350 bar).
- Suitable for use in load holding applications.
- Incorporates the Sun floating style construction to minimize the possibility of internal parts binding due to excessive installation torque and/or cavity/cartridge machining variations.

Technical Data

	U.S. Units	Metric Units
Cavity	T-17A	
Capacity	60 gpm	240 L/min.
Adjustment - Number of Clockwise Turns to Increase Setting	5	
Factory Pressure Settings Established at	4 gpm	15 L/min.
Maximum Operating Pressure	5000 psi	350 bar
Maximum Valve Leakage at Reseat	10 drops/min.	0,7 cc/min.

Response Time - Typical	2 ms	
Reverse Flow Check Cracking Pressure	20 psi	1,5 bar
Series (from Cavity)	Series 3	
U.S. Patent #	4,834,135	
Valve Hex Size	1 1/4 in.	31,8 mm
Valve Installation Torque	150 - 160 lbf ft	200 - 215 Nm
Adjustment Screw Hex Socket Size	5/32 in.	4 mm
Adjustment Nut Hex Size	9/16 in.	15 mm
Adjustment Nut Torque	108 lbf in.	12 Nm
Model Weight	1.50 lb	0,70 kg
Seal Kits	Buna: 990-017-007	
Seal Kits	Viton: 990-017-006	

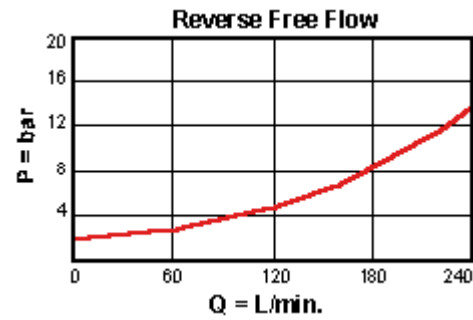
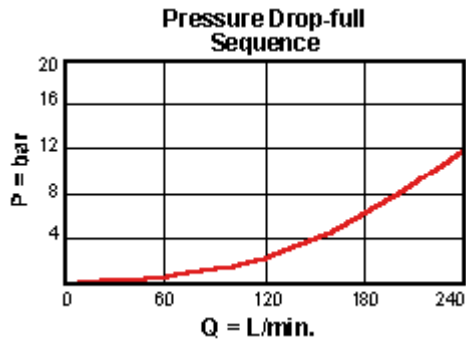
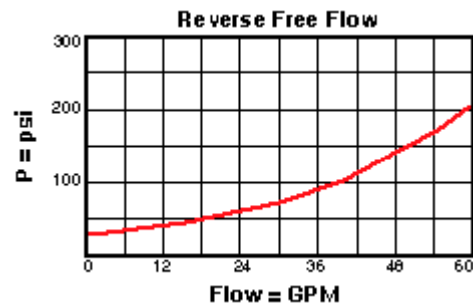
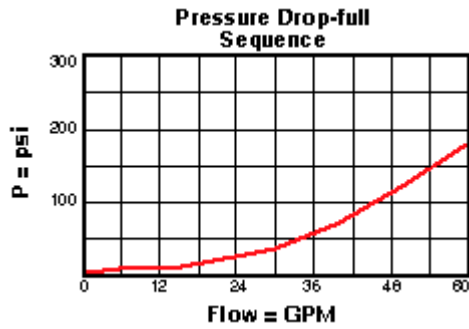

SCGA-LDN

Control

Adjustment Range

External Material/Seal Material

L Standard Screw Adjustment

+0.00 200 - 800 psi (14 - 55 bar), 400 psi (30 bar) Standard Setting

+1.00 N Buna-N +0.00

Customer specified setting stamped on hex \$1.10

- Explanation of Sun cartridge control options - US units.
- Explanation of Sun cartridge control options - metric units.

