

Direct-acting relief valve

Capacity:
50 gpm (200 L/min.)

Functional Group:
Products : Cartridges : Relief : 2 Port : Direct Acting

Model:
RDFA-LAV

Product Description

Direct-acting relief cartridges are normally closed, pressure-limiting valves used to protect hydraulic components from pressure transients. When the pressure at the inlet (port 1) reaches the valve setting, the valve starts to open to tank (port 2), throttling flow to limit the pressure rise. These valves are smooth and quiet, essentially zero leak, dirt tolerant, immune to silting and are very fast.

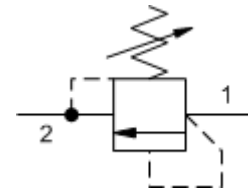

Download

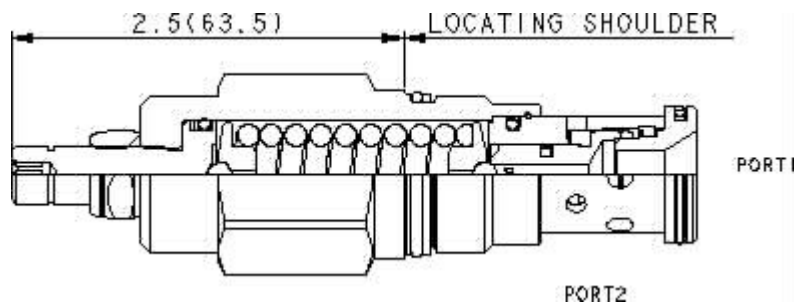

Technical Features

- Will accept maximum pressure at port 2; suitable for use in cross port relief circuits.
- The seals on the adjust screw are exposed to system pressure which means this valve can only be adjusted when the pressure is removed. The setting procedure is; check the setting, remove the pressure, adjust the valve, check the new setting.
- Valve is relatively insensitive to varying oil temperatures and oil borne contamination.
- Select a spring range where the desired relief setting is approximately mid-range between the minimum and maximum pressure to ensure maximum valve repeatability.
- Suitable for use in load holding applications.
- Back pressure on the tank port (port 2) is directly additive to the valve setting at a 1:1 ratio.
- All 2-port relief cartridges (except pilot reliefs) are physically and functionally interchangeable (same flow path, same cavity for a given frame size).
- Incorporates the Sun floating style construction to minimize the possibility of internal parts binding due to excessive installation torque and/or cavity/cartridge machining variations.

Technical Data

	U.S. Units	Metric Units
Cavity		T-3A
Capacity	50 gpm	200 L/min.
Adjustment - Number of Clockwise Turns to Increase Setting		5
Factory Pressure Settings Established at	4 gpm	15 L/min.
Maximum Operating Pressure	5000 psi	350 bar
Maximum Valve Leakage at Reseat	10 drops/min.	0,7 cc/min.
Response Time - Typical		2 ms
Series (from Cavity)		Series 2

U.S. Patent #	4,742,846	
Reseat	>90 % of Set Pressure	
Valve Hex Size	1 1/8 in.	28,6 mm
Valve Installation Torque	45 - 50 lbf ft	60 - 70 Nm
Adjustment Screw Hex Socket Size	5/32 in.	4 mm
Adjustment Nut Hex Size	9/16 in.	15 mm
Adjustment Nut Torque	108 lbf in.	12 Nm
Model Weight	.50 lb	0,25 kg
Seal Kits	Buna: 990-303-007	
Seal Kits	Viton: 990-303-006	

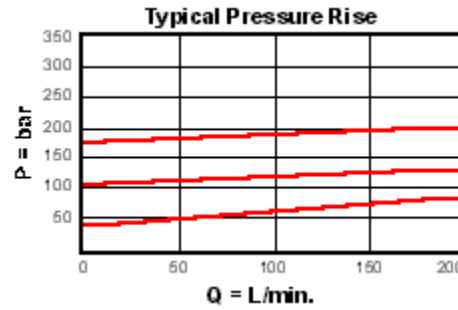
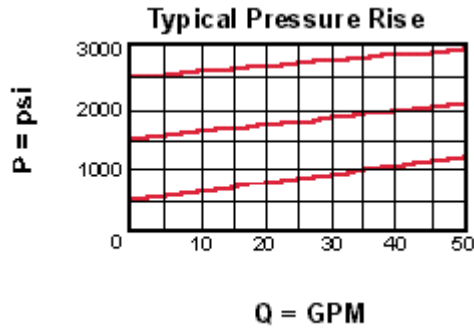

RDFA-LAV

Control

Adjustment Range

External Material/Seal Material

L Standard Screw Adjustment	+0.00	500 - 3000 psi (35 - A 210 bar), 1000 psi (70 bar) Standard Setting	+0.00	V Viton +3.50
-----------------------------	-------	---	-------	---------------

If the control is 3, the range must be A,C or D
 If the control is K, the range must be E or S
 If the material/seal is P, the control must be L or C
 If the material/seal is W, the control must be L or C

Customer specified setting stamped on hex \$1.10

- Explanation of Sun cartridge control options - US units.
- Explanation of Sun cartridge control options - metric units.
- Two-piece, floating cartridge construction.

Copyright © 2007-2008 Sun Hydraulics Corporation. All rights reserved.
 Terms and Conditions - ISO Certification - Statement of Privacy