

MODEL RD-1800 PRESSURE RELIEF MODEL RD-900 SELECTOR VALVE

MODEL RD-1800 BALL/SRING TYPE DIRECT ACTING RELIEF

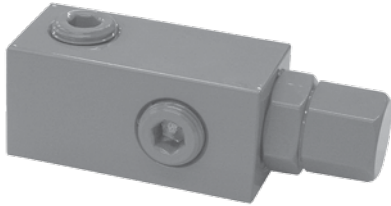

RELIEF VALVE CURVE
AT VARIOUS SET POINTS
110 SUS OIL AT 115°F.

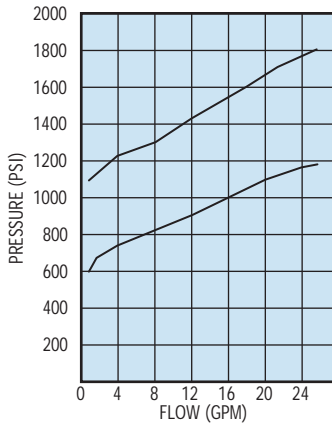

The PRINCE valve model RD-1800 is a direct acting ball/spring type pressure relief. The valve is compact and simple in design. This type relief is fast opening and is well suited for pressure spike protection. The performance curves below indicate the low cracking pressure typical to ball/spring reliefs. Please refer to the model RV relief for a system pressure relief. The valve is available with a standard steel seat, model RD-1800S, or with a hardened seat, model RD-1800H. Both models are externally adjustable.

VALVE SPECIFICATIONS:

Capacity: 20 gpm max inlet flow
Pressure: 2500 psi max
Weight: 2 lb.
Adjustment Range: 1000 PSI to 2500 PSI

SYMBOL

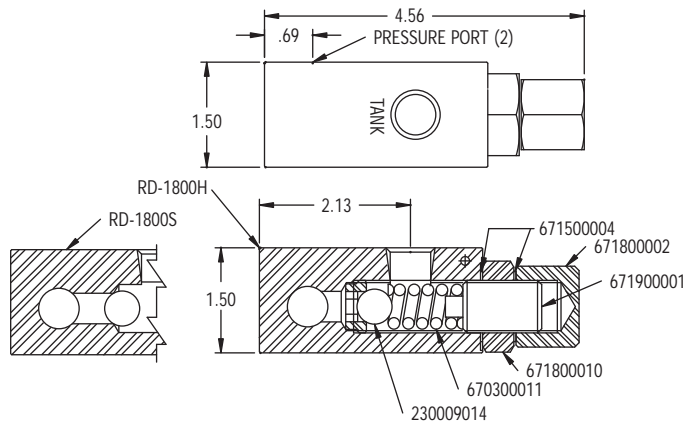
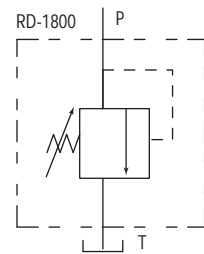

NOTE: Relief settings are 1500 PSI @ 12 GPM.
For non-standard relief settings specify PSI in hundreds and GPM after model number.
EX: RD-1850S-12-10 for 1200 PSI @ 10 GPM

STANDARD MODELS AVAILABLE

MODEL #	PORT SIZES	MAX FLOW
RD-1837S	3/8 NPTF	8 GPM
RD-1850H	1/2 NPTF	16 GPM
RD-1850S	1/2 NPTF	16 GPM
RD-1875S	3/4 NPTF	20 GPM

MODEL RD-900 SELECTOR VALVE

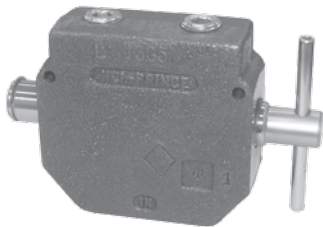

The PRINCE valve model RD-900 is a manual 3-way 2-position selector valve. This valve will allow one pump source to supply two separate circuits. Pushing the handle in diverts oil flow to port away from handle. Pulling the handle out diverts oil flow to port nearest handle.

VALVE SPECIFICATIONS

Capacity: 30 gpm max inlet flow
Pressure: 3000 psi max
Weight: 7 lbs.



SYMBOL

STANDARD MODELS

MODEL #	PORT SIZES
RD-950	1/2 NPTF
RD-975	3/4 NPTF

SEAL KIT 660590025

