

Pilot operated, pressure reducing/relieving valve

Capacity:
10 gpm (40 L/min.)

Functional Group:

Products : Cartridges : Reducing/Relieving : 3 Port : Pilot Operated

Model:

PPDB-LNN

Product Description

Pilot-operated, pressure reducing/relieving valves reduce a high primary pressure at the inlet (port 2) to a constant reduced pressure at port 1, with a full-flow relief function from port 1 to tank (port 3).

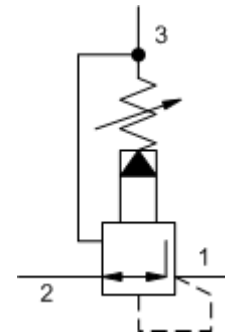

Download

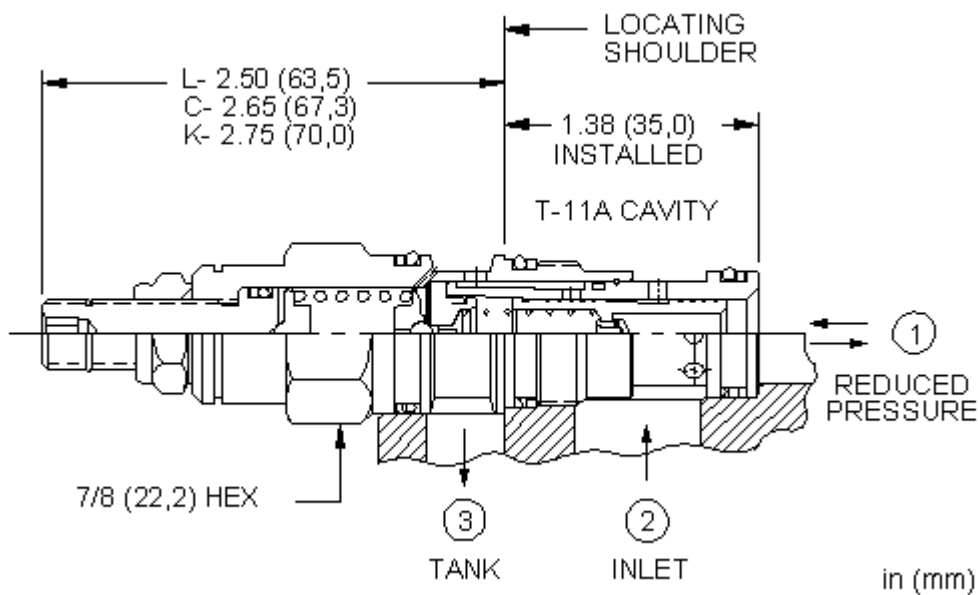

Technical Features

- Full reverse flow from reduced pressure (port 1) to inlet (port 2) may cause the main spool to close. If reverse free flow is required in the circuit, consider adding a separate check valve to the circuit.
- Recommended maximum inlet pressure is determined by the adjustment range. Ranges D, E, N, and Q are tested with a 2000 psi (140 bar) maximum differential between inlet and reduced pressure. Ranges A, B, and H are tested with a 3000 psi (200 bar) maximum differential between inlet and reduced pressure. Ranges C and W are tested with 5000 psi (350 bar) of inlet pressure.
- If pilot flow consumption is critical, consider using direct acting reducing/relieving valves.
- Pilot operated valves exhibit exceptionally flat pressure/flow characteristics, are very stable and have low hysteresis.

- Pressure at port 3 is directly additive to the valve setting at a 1:1 ratio and should not exceed 5000 psi (350 bar).
- All three-port pressure reducing and reducing/relieving cartridges are physically interchangeable (i.e. same flow path, same cavity for a given frame size). When considering mounting configurations, it is sometimes recommended that a full capacity return line (port 3) be used with reducing/relieving cartridges.
- Pilot operated reducing, reducing/relieving valves by nature are not fast acting valves. For superior dynamic response, consider direct acting valves.
- Incorporates the Sun floating style construction to minimize the possibility of internal parts binding due to excessive installation torque and/or cavity/cartridge machining variations.

Technical Data

	U.S. Units	Metric Units
Model Weight	0.32 lb.	0.15 kg.
Cavity	T-11A	
Capacity	10 gpm	40 L/min.
Adjustment - Number of Clockwise Turns to Increase Setting	5	
Control Pilot Flow	7 - 10 in ³ /min.	0,11 - 0,16 L/min.
Factory Pressure Settings Established at	blocked control port (dead headed)	
Maximum Operating Pressure	5000 psi	350 bar
Series (from Cavity)	Series 1	
Valve Hex Size	7/8 in.	22,2 mm
Valve Installation Torque	30 - 35 lbf ft	45 - 50 Nm
Adjustment Screw Hex Socket Size	5/32 in.	4 mm
Adjustment Nut Hex Size	9/16 in.	15 mm
Adjustment Nut Torque	108 lbf in.	12 Nm
Seal Kits	Buna: 990-011-007	
Seal Kits	Viton: 990-011-006	

No Load Pressure Drop with Valve Full Open

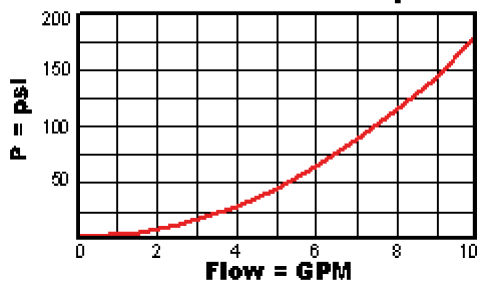

Regulated Pressure

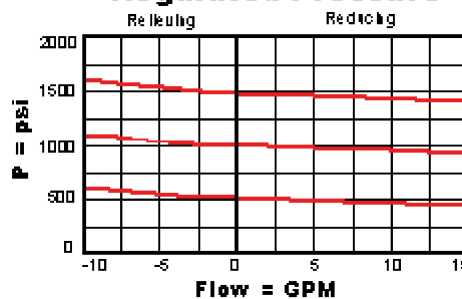

No Load Pressure Drop with Valve Full Open

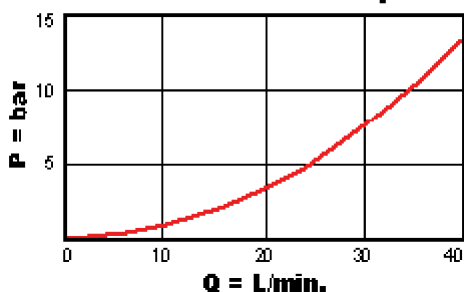

Regulated Pressure

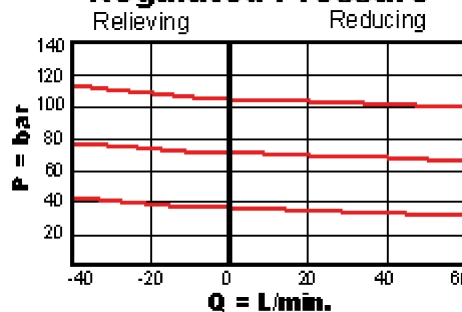

Control

Adjustment Range

External Material/Seal
Material

L Standard Screw Adjustment	+0.00	60 - 800 psi (4 - 55 N bar), 200 psi (14 bar) Standard Setting	+1.00	N Buna-N +0.00
--------------------------------	-------	--	-------	----------------

If the material/seal is P, the control must be L or C
If the material/seal is W, the control must be L or C

* Special Setting required, specify at time of order
Customer specified setting stamped on hex \$1.10

Related Models
PPDB8

- Explanation of Sun cartridge control options - US units.
- Explanation of Sun cartridge control options - metric units.

Copyright © 2007-2008 Sun Hydraulics Corporation. All rights reserved.
Terms and Conditions - ISO Certification - Statement of Privacy