



Donaldson Delivers

Clean Fuel & Lubricant Solutions™



Clean Fluids.
Keep Running.™

Clean Fuel & Lubricant Solutions

For filtration challenges downstream of the refinery, from delivery to the bulk tank right up to the final point of use.

Filter Selection	6
Single-Pass Filtration	7
Clean	
Filters and Filter Heads	8
Manifold Assemblies	9
Protect	
Breather and Air Reservoir Vent	10
Polish	
Point-of-Use Filters and Filter Heads	11
System Design	
Understanding ISO Codes	12
Temperature and Viscosity	13
Flow Rate and Pressure	14
System Sizing	15
Contact Us	16



Why Filter Fuels & Lubricants?

The sophistication of today's equipment, such as the increase in injection pressures on diesel engines, requires higher cleanliness levels than ever before.

Donaldson bulk filtration systems can save on costly component replacement, minimize downtime, and prevent a decrease in fuel efficiency due to injector wear. **In short, Donaldson reduces your total cost of ownership.**



Typical storage tank contaminated with dirt, water, and microbial growth

Fuels and oils are transported from the refinery to the bulk tank storage site by truck, rail or pipeline.



From there it is loaded into another truck and delivered to your site.



Once in storage at your site, it can either be transferred to smaller tanks or dispensed directly into equipment.



Each time fluids are transferred, more contamination can be introduced.



Contaminants and water are the enemies of fuels and lubricants, robbing vehicles and equipment of performance and longevity.

Removing contaminants with bulk filtration prior to pumping fluids into equipment allows on-board filtration systems to do their job better, while supporting the advanced system technology required to meet new regulations.

Clean.

1 Donaldson single-pass filtration on the inlet reduces the risk of contamination in bulk storage tanks and helps maintain desired cleanliness levels.

Compact and easy to replace, Donaldson filters are an important line of defense in maintaining fluid quality, and can be configured for high flow rates while minimizing pressure drop.

Protect.

2 Water absorbing filters, T.R.A.P.[™] breathers and Active Reservoir Vent[™] (ARV) products reduce the risk of moisture and contaminants entering a bulk storage tank so that fluids are kept clean and dry. Used together, they'll help guard fluids from free water, airborne contamination and microbial growth for as long as they stay in storage.

Polish.

3 Because unstable fluids and the tank itself can be a source of contamination, final filtration on the outlet with Donaldson filters ensures that targeted ISO cleanliness levels are achieved.

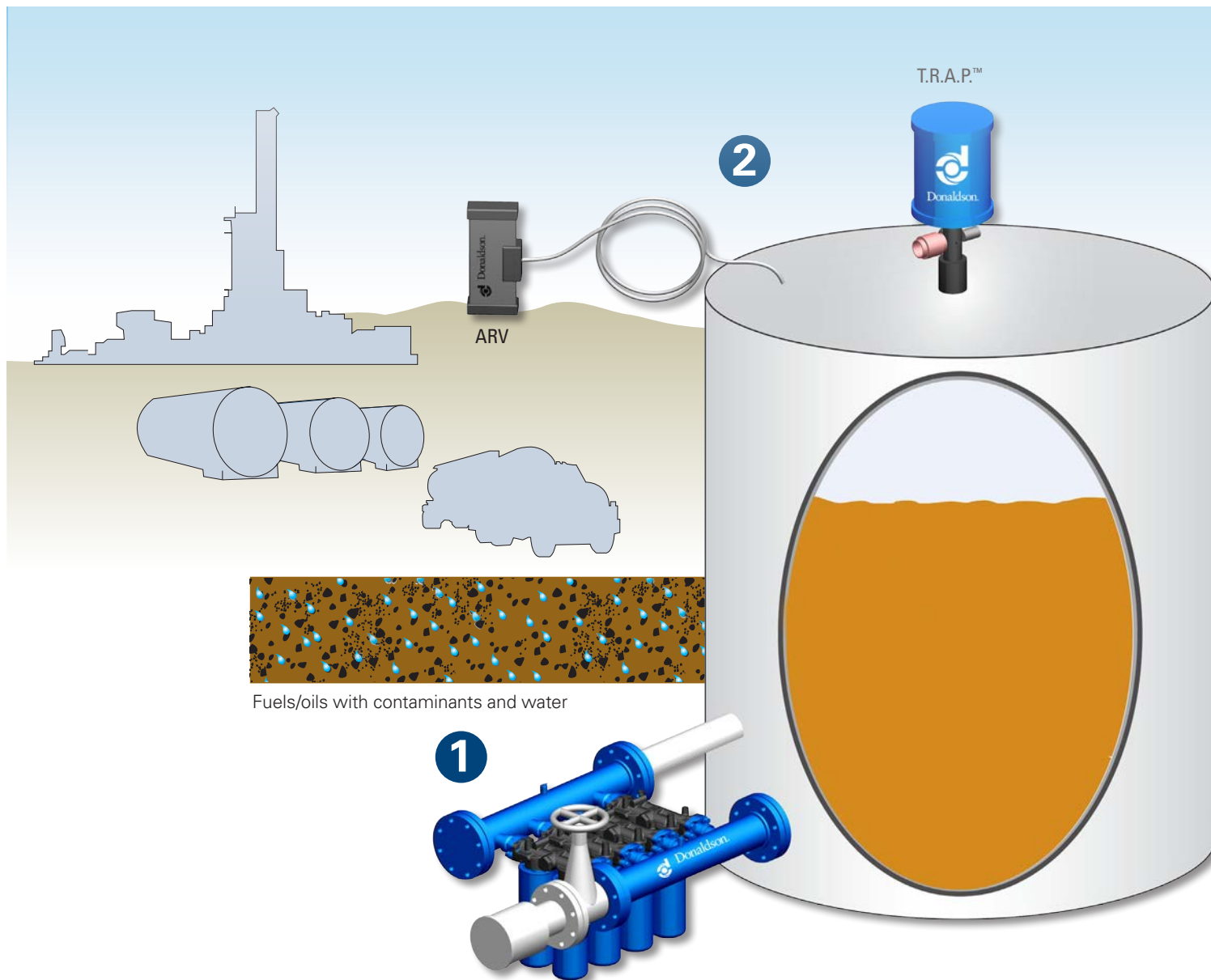



Donaldson Delivers Superior Bulk Fluid Filtration

Increased availability

Lower total cost of ownership

Modular solutions

Custom designs

Compact installation

Low installation costs

Easily serviced

Easily shipped

Variable flow rates

Minimal pressure drop

Material compatibility

Low inventory costs

Maximize Fuel Efficiency

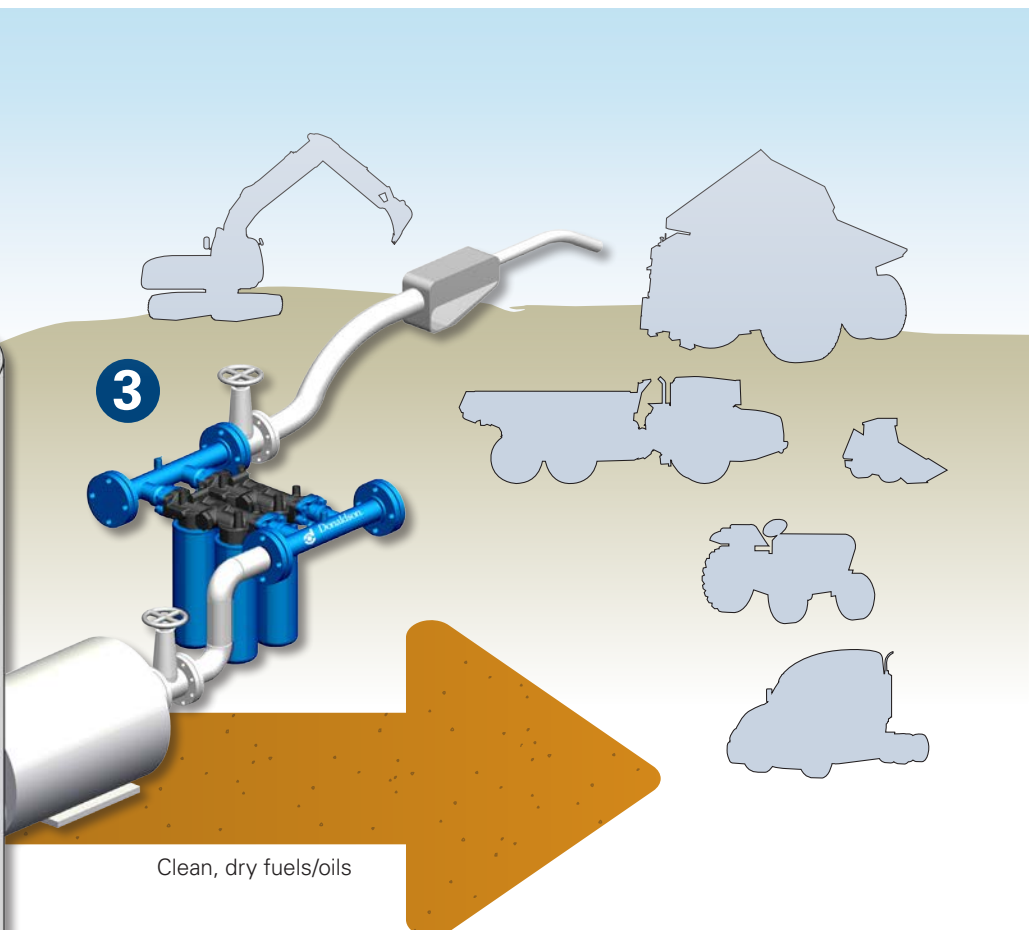

Clean, dry fuels/oils

 **Clean. Protect. Polish.™**

Choosing the Right Filter

Achieving the Target Cleanliness of a Fluid

ISO 4406 contamination codes consist of three numbers corresponding to the number of particles of 4 microns and larger, 6 microns and larger, and 14 microns and larger present in the fluid. This page illustrates what it means to start with a contamination of ISO 22/21/18 and target a cleanliness of ISO 14/13/11.

Sizes of Familiar Particles in Microns

Grain of table salt	100 µm	Talcum powder	10 µm
Human hair	80 µm	Red blood cell	8 µm
Lower limit of visibility	40 µm	Bacteria	2 µm
White blood cell	25 µm	Silt	<5 µm

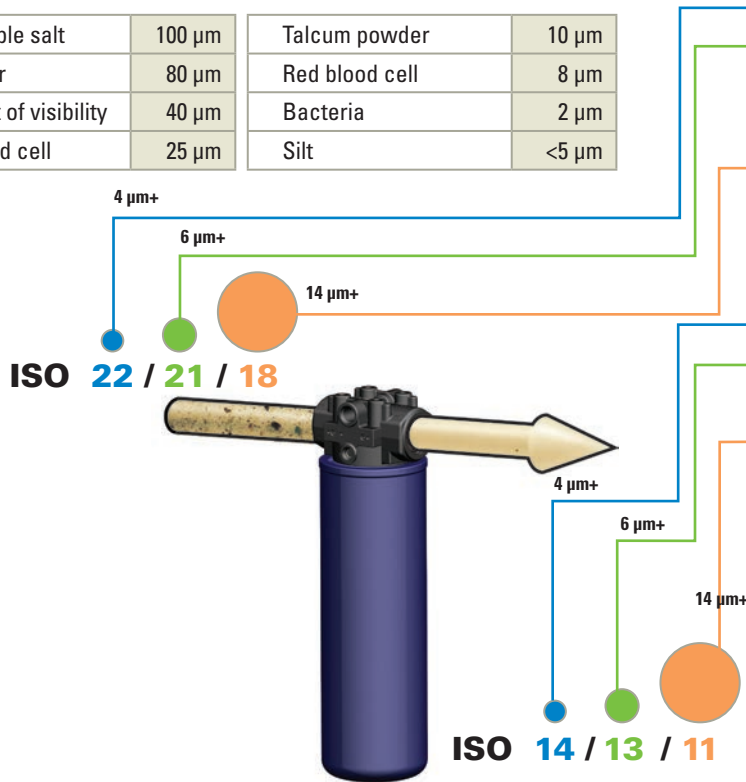

ISO 4406 Contamination Codes

Range of number of particles per milliliter

Code	More Than	Up to & Including
24	8,000,000	16,000,000
23	4,000,000	8,000,000
22	2,000,000	4,000,000
21	1,000,000	2,000,000
20	500,000	1,000,000
19	250,000	500,000
18	130,000	250,000
17	64,000	130,000
16	32,000	64,000
15	16,000	32,000
14	8,000	16,000
13	4,000	8,000
12	2,000	4,000
11	1,000	2,000
10	500	1,000
9	250	500
8	130	250
7	64	130
6	32	64
5	16	32
4	8	16
3	4	8
2	2	4
1	1	2

Donaldson Recommended ISO Cleanliness Ratings

ISO 22/21/18

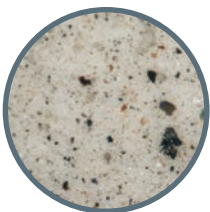

Typical cleanliness of delivered fluids

ISO 18/16/13

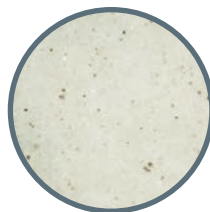

Target rating for heavy gear/engine oils

ISO 16/14/11

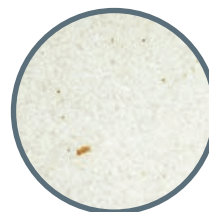

Target rating for hydraulic/transmission oils

ISO 14/13/11



Target rating for diesel fuel

Single Pass Filtration

Designed for systems of any size, with minimal pressure drop

Donaldson bulk assemblies are manufactured and piped in parallel flow configurations to reduce pressure drop across the assembly, providing single-pass filtration performance, resulting in the targeted fluid cleanliness.

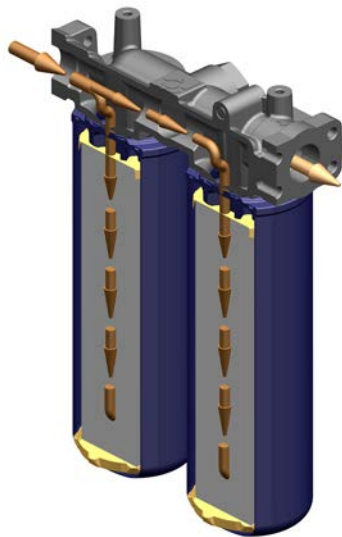

The flow is split between the two filters shown. Half of the flow travels through the first filter and the remaining flow travels through the second filter. Flow does not travel through both filters in sequence.

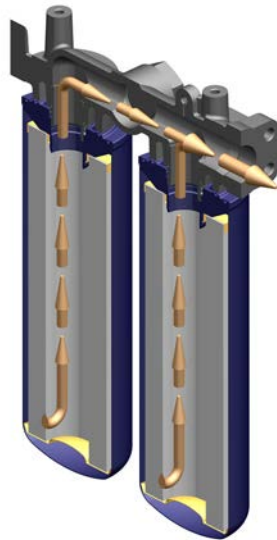

Fluids pass through the media and cleanliness targets are achieved in a single pass.

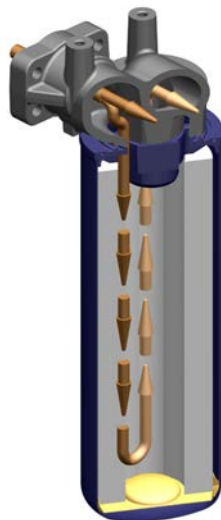

Clean fluid is pushed out of the filter, through the head and out into storage or for use.

*ISO 4406 is a multi-pass system

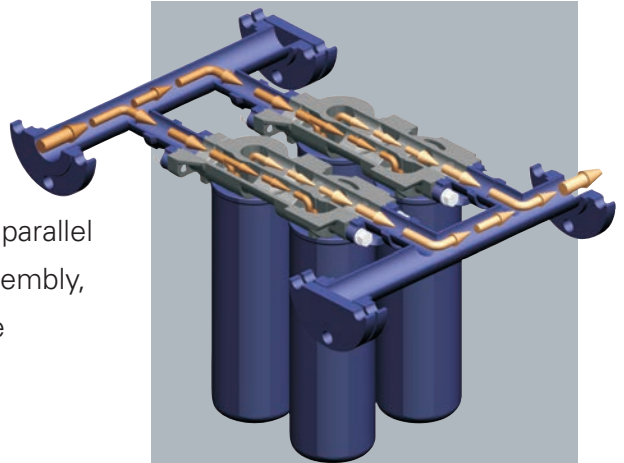

Donaldson Delivers Material Compatibility

Donaldson bulk heads are constructed of aluminum with steel inserts to prevent excessive metal-to-metal bonding, or galling, between the head and the filter.

Viton® seals are used in all designs to maintain compatibility with most fluids. All bulk filter head utilize o-ring seals

Manifolds are constructed of painted carbon steel pipe with SAE 150 flanges. Manifolds are used to plumb together multiple dual heads (P568583) to handle high flow rates.

Viton is a registered trademark of E. I. du Pont de Nemours and Company.

Filters and Filter Heads

Clean fuels and oils on the inlet side to maintain cleanliness levels in bulk storage tanks. These products can also be used on the outlet.

FILTERS	Typical Fluid Applications	Max. Working Pressure	Rated Static Burst	Max. Flow Range	Operating Temperature	Target Iso Cleanliness	ISO Filter Efficiency
P568664	Engine Oil and Gear Oil	350 PSI/24.1 bar	800 PSI/55.2 bar	65 gpm/246 lpm	-40°F-190°F/-40°C -88°C	18/16/13	25 micron@ Beta 2000
P568665	Transmission Oil and Hydraulic Oil					16/14/11	7 micron @Beta 2000
P568666	All Fuels					14/13/11	4 micron@Beta 2000
P570248	Water-Absorbing for Ethanol-Free Fluids*						20 micron@Beta 2000

*Designed with expanding media that prevents water from entering storage or equipment tanks. Not recommended for contamination removal.



P568664

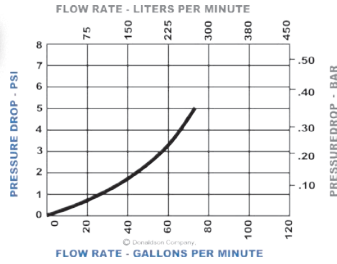

P568666

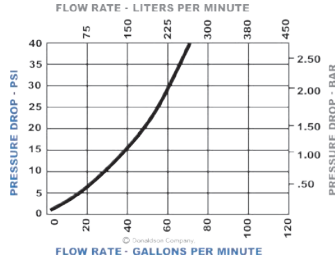

P568665

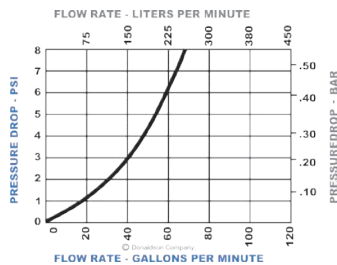

P570248

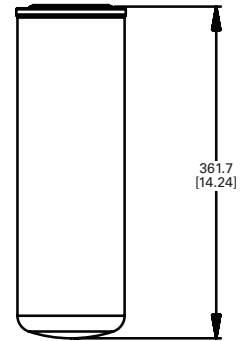
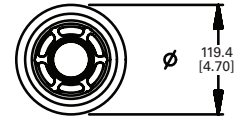
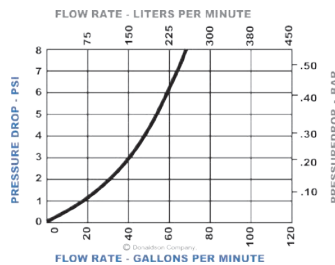

FILTER HEADS

Filter Quantity	Mounting Connection	Max. Working Pressure	Rated Static Burst	Max. Flow Range
P570329	SAE-20 O-Ring	350 PSI/24 bar	800 PSI/55 bar	65 gpm/246 lpm
P570330	1 1/4" NPT			65 gpm/246 lpm
P568583	1 1/2" SAE 4-Bolt			125 gpm/473 lpm

All Filter Heads

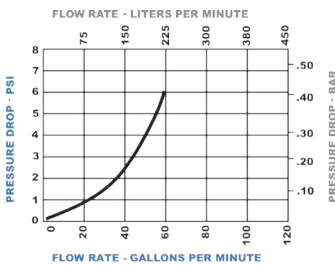

Rotate clockwise to install filter. 2" clearance necessary to change filter

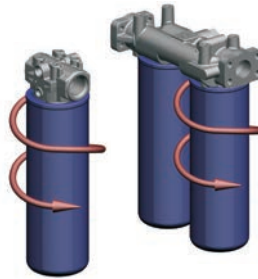

P570329

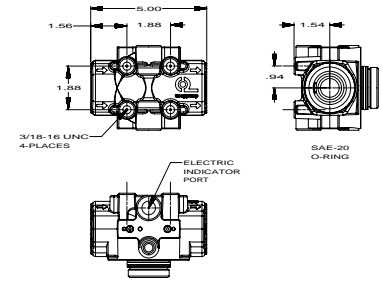

P570330

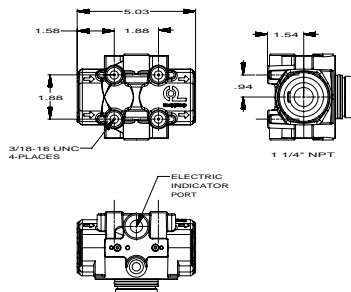

P568583

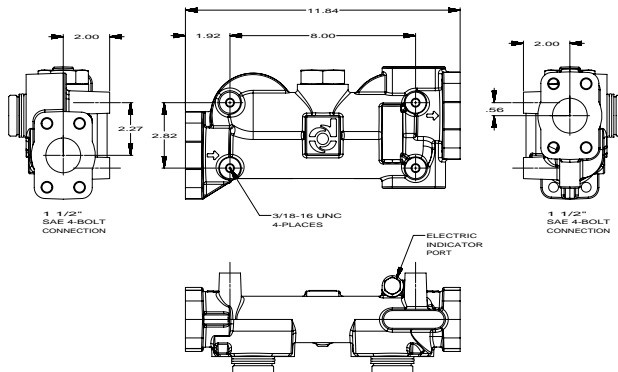

Manifold Assemblies



MANIFOLDS	Filter Quantity	Mounting Connection	Max. Flow Range
P561880	4	2" 150 Flange	250 gpm/946 lpm
P568932	8	4" ANSI 150 Flange	500 gpm/1893 lpm
P568933	10	4" ANSI 150 Flange	600 gpm/2271 lpm

P561880

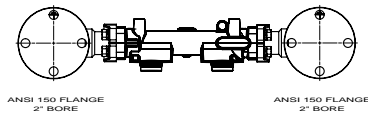
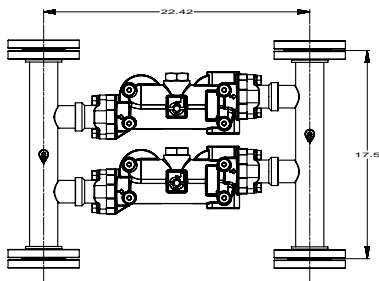
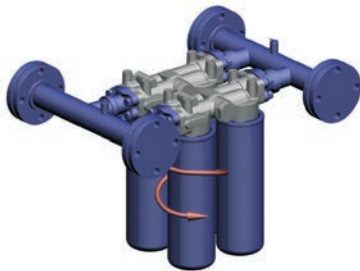
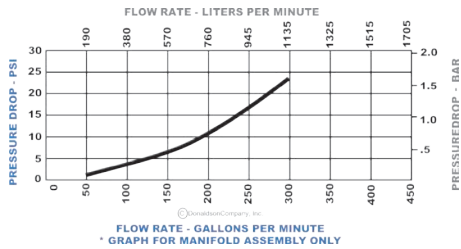

P568932

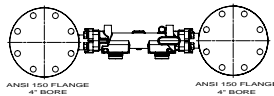
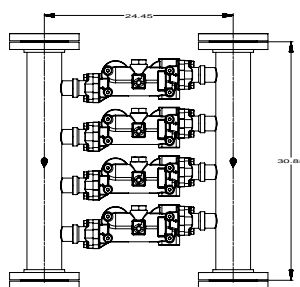
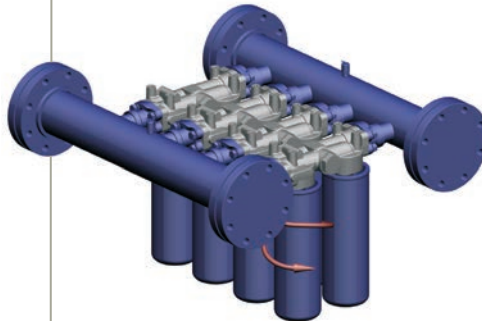
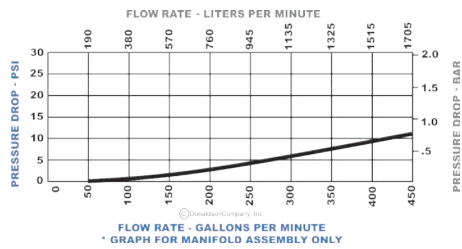

P568933

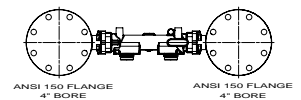
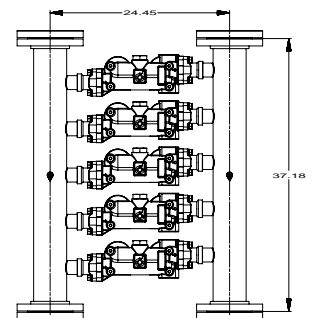
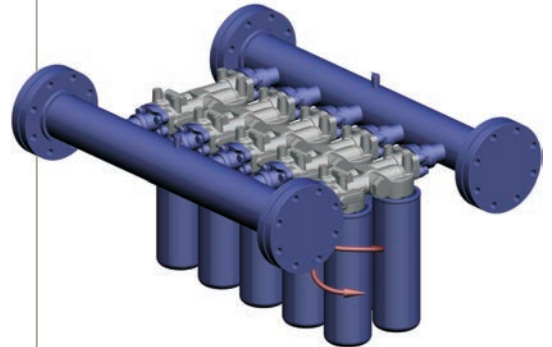
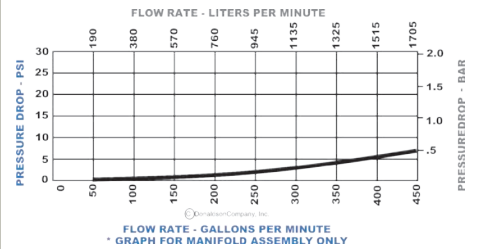

Protect

Protect your investment while it's in storage

The Donaldson T.R.A.P.^{TM1} breather reduces the risk of dust and moisture entering storage tanks from the vent while allowing high flow rates of fluid into and out of the tank.

Protect fluids in storage from moisture with Active Reservoir VentTM (ARV). It draws moisture from fluids with dry compressed air².

¹Thermally Reactive Advanced Protection

²Compressed air and power not provided by Donaldson

An **ARV** blows a blanket of dry air over fluids in storage to remove free and emulsified water.



ARV	Flow Rate (scfm)	Recommended Maximum Reservoir Size	Height	Width	Depth	Weight	Medium	Mounting Connection	Electrical Requirements
P568790	3	10,000 Gal/37,900 Liters	14"/355 mm	12"/300 mm	5"/127 mm	15 lbs/7 kg	Compressed Air/Nitrogen	1/2" NPTF	110 V/50-60 Hz AC, Approx.4W
P568791	10	30,000 Gal/113,700 Liters	35"/889 mm			33 lbs/15 kg			

T.R.A.P.TM breathers prevent dirt and moisture from entering storage tanks from the vent, resulting in cleaner, drier air.

T.R.A.P. BREATHER	Max.Flow Range	Filter Efficiency	Replacement filter	Connection
KYX920006	500 gpm/1893 lpm	>97% at 3 micron	P923075	1.5" NPT Female

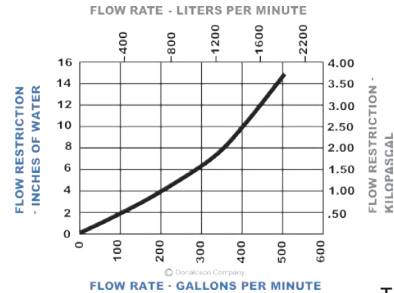

How a T.R.A.P.TM Breather Works

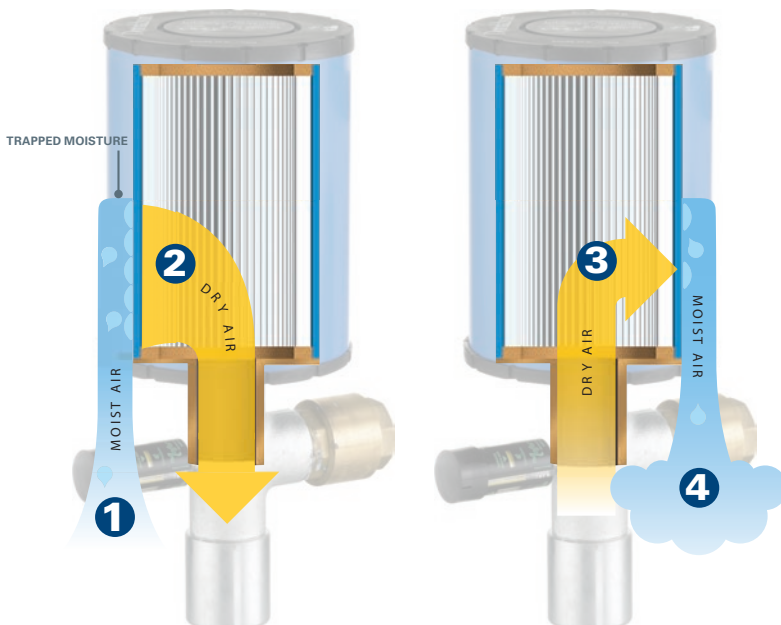

Intake Cycle (Inhalation)

- 1 The circuit "breathes in" air containing moisture vapor.
- 2 The T.R.A.P. breather strips moisture and particulate from the incoming air, allowing only clean, dry air to enter the circuit.

Outflow Cycle (Exhalation)

- 3 During the "exhalation" cycle, The T.R.A.P. breather allows unrestricted airflow outward.
- 4 The outflow of dry air picks up the moisture collected by the T.R.A.P. breather during intake, and "blows it back out" – fully regenerating the T.R.A.P. breather's water-holding capacity.

Polish

Designed for high pressure delivery systems out of bulk storage tanks

Point-of-use products “polish” or remove any contaminants that may have been picked up in storage or during final transfer. Heads, filters and manifolds highlighted in the “Clean” section (on pages 8-9) are also used to polish fluids as they come out of storage. For higher-pressure delivery systems refer to the products below.

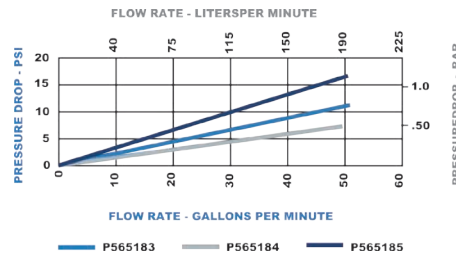

Rotate clockwise to install filter
2" clearance necessary to change filter

POINT-OF-USE FILTERS

Typical Fluid Applications

Filter Model	Typical Fluid Applications	Element Collapse Rating	Max. Working Pressure	Rated Static Burst	Max. Flow Range	Operating Temperature	Micron	Seals
P565183	For Hydraulic, Gear, Transmission and Engine Oils	300 PSI/20 Bar	800 PSI/55 Bar	1700 PSI/117 Bar	50 gpm/189 lpm	-20°F-250°F/-29°C-121°	15	Viton®
P565184							4	
P565185							7	
P569826	For Skydrol®	300 PSI/20 Bar	800 PSI/55 Bar	1700 PSI/117 Bar	50 gpm/189 lpm	-20°F-250°F/-29°C-121°	2	EPDM
P569824							5	
P569823							8	
P569825							14	

POINT-OF-USE FILTER HEADS

Filter Head Model	Max. Working Pressure	Rated Static Burst	Max. Flow Range	Filter Quantity	Operating Temperature	Material	Compatible Filters	Mounting Connection
P566023	800 PSI/55 Bar	1700 PSI/117 Bar	50 gpm/189 lpm	1	-40DF-250DF/-40DC-121 DC	Aluminum head with Viton seals	P565183	Single Head SAE-16 O-Ring
P566024							P565184	Single Head with 50 PSI /3.5 Bar Bypass SAE-16 O-Ring
P569830						Aluminum head with EPDM seals for Skydrol®	P569826	Single Head SAE-16 O-Ring
P569831						P569824	Single Head with 50 PSI /3.5 Bar Bypass SAE-16 O-Ring	
	P569823							
	P569825							

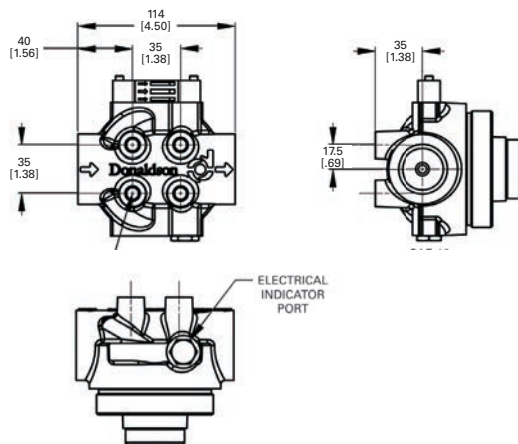
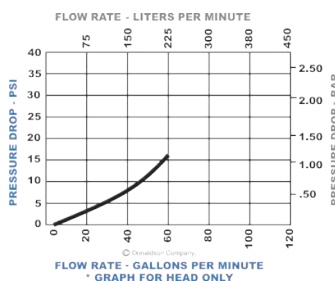

Plastic point-of-use filter cartridges and metal housings are easily separated for recycling.

Skydrol is a registered trademark of Solutia Inc.

Understanding ISO Codes

Choosing the ideal filters for your system doesn't need to be complicated. Just remember a few key principles:

Fluid viscosity plays an important role in restricting the flow through filters. It's crucial to select the proper filter to maintain adequate flow and avoid excessive pressure drops (see page 13 for viscosity data).

Selecting the right micron rating to achieve targeted ISO cleanliness without overbuilding the system will help avoid unnecessary cost.

Different types of oil have different properties. Choose a filter with the most compatible media-to-fluid properties.

Data Necessary for Sizing Filtration Systems

Fluid usage

Fluid properties to determine viscosity at transfer temperature

Flow rate and pressure

Typical Fluid Applications	Viscosity	Target Iso Cleanliness	FILTERS
Diesel Fuel	0-100 cSt	14/13/11	P568666
Transmission Oil Hydraulic Oil Glycols <150°F Hydraulic Based Water Emulsions	0-500 cSt	16/14/13	P568665
Engine Lube Oils Gear Oils Glycols Phosphate Esters	0-6000 cSt	18/16/13	P568664



Donaldson Delivers Water Detection



Are your bulk fluids passing large amounts of free water downstream – contaminating vehicles and equipment?

Water detection filters and systems, constructed with super absorbent media, will help you prevent downstream contamination. Installation of Donaldson's water absorbing filter (P570248) will stop flow if large amounts of free water are detected in your fluids. Designing systems with water detection filters requires careful sizing considerations. A Donaldson specialist will assist in configuring a system that meets your specific needs for flow and pressure drop.

Temperature and Viscosity

The Importance of Temperature in Sizing Your Filtration System

Fluid viscosity, measured in centistokes (cSt) or Saybolt Seconds Universal (SSU or SUS), is the resistance of a fluid to flow (thickness of fluid). Low viscosity fluids pass through filters with less resistance than high viscosity fluids. Higher fluid viscosities have higher pressure drops due to higher resistance passing through the media.

The colder the fluid, the higher the viscosity, so the lowest potential temperature of the fluid is the best measure for sizing a bulk filtration system. Due to the high specific heat capacity of fluids, the lowest ambient temperature may not be an accurate reflection of the actual fluid temperature. Avoid oversizing your system by using the stored fluid temperature and not the lowest ambient temperature, which tends to be lower than the temperature of the fluid in storage or transport.

Data Necessary for Sizing Filtration Systems

Fluid usage

Fluid properties to determine viscosity at transfer temperature

Flow rate and pressure

Fuel/Oil Kinematic Viscosity Combined With Temperature in Centistokes cSt

SAE Gear Oil			75W			80W	85W	90			140		
SAE Engine Oil			5W	10W		20		30	40	50			
ISO Grade			15	22	32	46	68	100	150	220	320	460	680
°F	°C	Diesel											
248	120				3.7	3.5	5.7	7.3	9.3	11.7	14.7	18.2	22.9
230	110				4.4	5.5	7.0	9.0	11.7	14.9	18.9	23.7	30.2
212	100		1	4.5	5.4	6.8	8.8	11.4	15.0	19.4	25.0	31.8	41.1
194	90		3	5.3	6.7	8.5	11.2	14.8	19.8	26.0	34.1	44.0	57.9
176	80		5	6.5	8.5	11.0	14.8	19.9	27.1	36.2	48.2	63.3	84.8
158	70		6.2	8.5	11.1	14.8	20.2	27.7	38.5	52.4	71.1	95.2	130
140	60		8	12	15.1	20.6	28.7	40.2	57.2	79.6	110	151	211
122	50		11	15	21.5	29.9	42.9	61.5	98.7	128	181	254	365
104	40	1	15	22	32	46	68	100	150	220	320	460	680
86	30	2	21	32	50.7	75.6	116	175	271	409	613	907	1380
68	20	3	33	51	86.7	135	214	334	536	838	1290	1980	3130
50	10	4	52	87	162	264	438	711	1190	1920	3070	4870	8020
32	0	5	85	180	340	585	1020	1720	2990	5060	8400	13900	23900
14	-10	9	185	375	820	1500	2770	4880	8890	15700	27200	47000	85000
-4	-20	15	400	800	2350	4650	9120	16800	32300	60000			

Flow Rate and Pressure

Bulk filtration systems need to be designed properly in order to meet a desired cleanliness rating. Choosing the correct filter and applying the right amount of filters for a specific viscosity to maintain minimal pressure drop is critical to configure an efficient system for a given application.

Data Necessary for Sizing Filtration Systems

Fluid usage

Fluid properties to determine viscosity at transfer temperature

Flow rate and pressure

Increased **flow rate** increases resistance as fluids pass through filters, making it harder to maintain ideal system pressure. Combined with viscosity, targeted flow rate is another critical factor in designing filtration systems.

These charts demonstrate the pressure drop experienced by fluids of various viscosities as the flow rate increases through a selected filter. The more vertical the line, the more filters need to be added to the system to distribute the volume of fluid, effectively reducing the flow rate through each filter and maintaining optimal pressure.

P568664 Engine Oil and Gear Oil

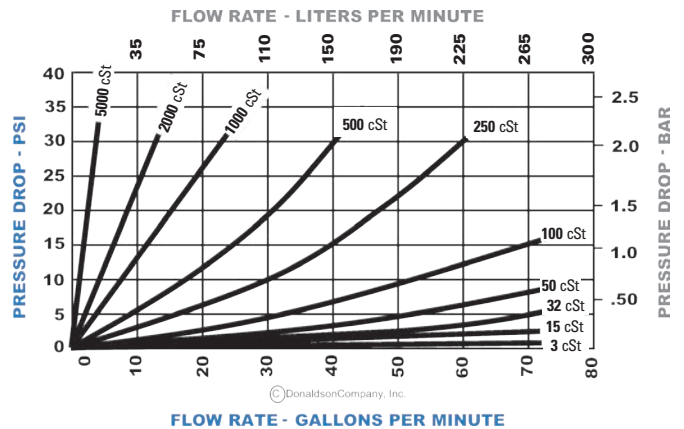

P568665 Transmission Oil and Hydraulic Oil

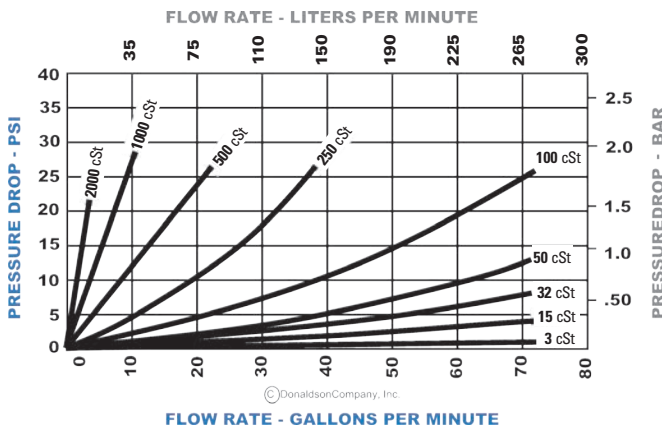

P568666 All Fuels

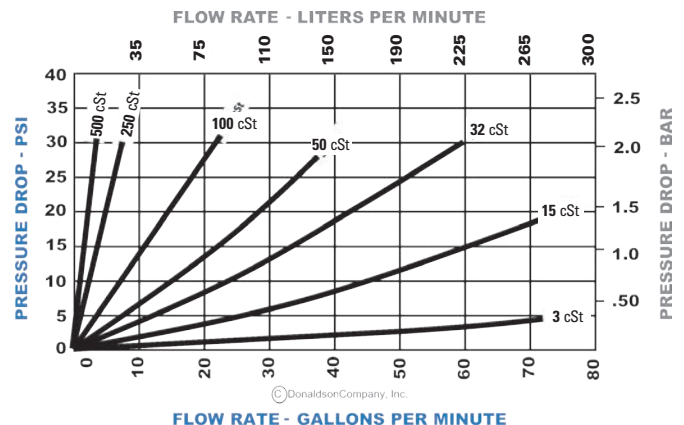

System Sizing

Customizing Your System

Steps to Sizing a Bulk Application

Example

1	Define product flow rate, fluid type and pressure drop restriction. <i>New systems should ideally have less than 15 PSI/1 Bar pressure drop.</i>	Flow rate	40 gpm/151 lpm
		Fluid type	ISO 68 hydraulic/transmission fluid
		System Pressure Drop	10 PSI/.7 Bar
2	Use the table on the previous page to determine fluid viscosity using the fluid type and temperature.	Temperature at transfer	68°F/20°C
		Viscosity of ISO 68 at 68°F/20°C	214 cSt
3	Select the appropriate filter (see pages 8 and 11).	P568665	
4	Determine the pressure drop using the flow rate and the fluid viscosity, according to the appropriate chart. <i>This number will be the pressure drop through one filter.</i>	20 PSI/1.4 Bar is the approximated pressure drop for ISO 68 at 68°F/20°C through a P568665 filter.	
5	Divide the pressure drop resulting from step 4 by the desired system pressure drop. This number is the amount of filters necessary to clean the fluid properly at the determined flow rate.	$\frac{20 \text{ (total PSI)}}{10 \text{ (system pressure drop)}} = 2$ $\frac{1.4 \text{ (total Bar)}}{.7 \text{ (system pressure drop)}} = 2$	
Result: This application requires two P568665 filters.			

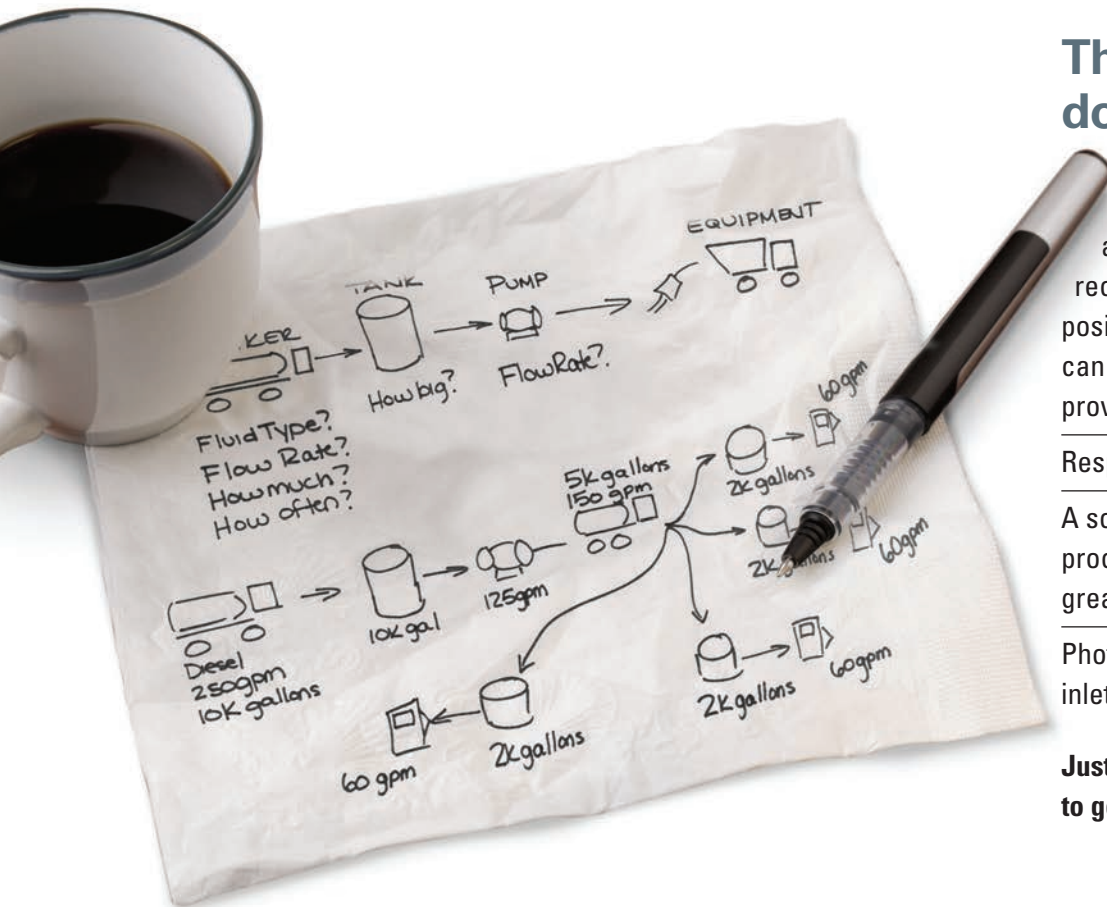

There's no need to do it alone.

Let a Donaldson specialist assist you by providing recommendations on sizing and positioning of Donaldson filters. You can help us design your system by providing:

Responses to steps 1-5 above.

A schematic of your fluid transfer process (hand sketches work great), and/or

Photographs of your site (tanks, inlets and outlets).

Just call the number on the back to get started.



Global Presence with Local Touch

Donaldson has established a global distribution network to serve our customers locally as well as worldwide. We operate as a global company with a network for primary distribution locations that support a mature hub of regional distribution centers and warehouses.

Donaldson distribution centers are strategically located to quickly and accurately deliver filtration and exhaust products wherever replacement products are needed. We work with a

network of transportation, third party logistics companies, consolidators, and cross-docking facilities to meet or exceed our customers' requirements.

All regions of the world benefit from our global umbrella of distribution centers. We focus our efforts on local support and the capabilities of our staff. We continue to make significant investments in facilities, systems, supply chain relationships and staffing to offer the best order fulfillment options available.

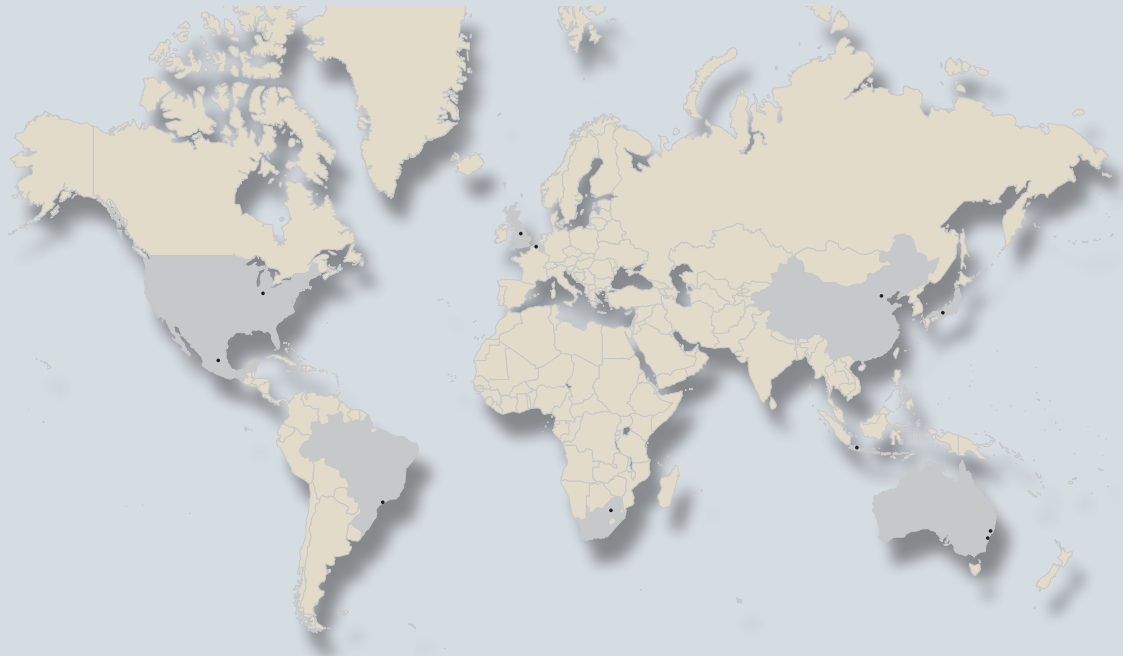

Donaldson Company, Inc.
PO Box 1299
Minneapolis, MN
55440-1299

www.buydonaldson.com
www.donaldsonbulkfiltration.com

Brochure No. F111500 (8/12)

© 2011 Donaldson Company, Inc. All rights reserved. Donaldson Company, Inc. reserves the right to change or discontinue any model or specification at any time and without notice. Printed in the U.S.A.

bulk.filtration@donaldson.com

North America 800-374-1374

Mexico, Latin America &
Caribbean 52-449-910-6150

Brazil 55-11-2119-1604

Europe 32-16-38-3811

South Africa 27-11-997-6000

South East Asia 65-6311-7373

Greater China 852-2405-8388

Japan 81-42-540-4112

Korea 82-2-517-3333

Australia 61-02-4350-2033

India 91-124-2290060