

FIK In-Tank, High Flow Filter

Working Pressures to: 145 *psi*
1000 kPa
10 bar

Rated Static Burst to: 217 *psi*
1500 kPa
15 bar

Flow Ranges to: 211 *gpm*
800 *l/min*

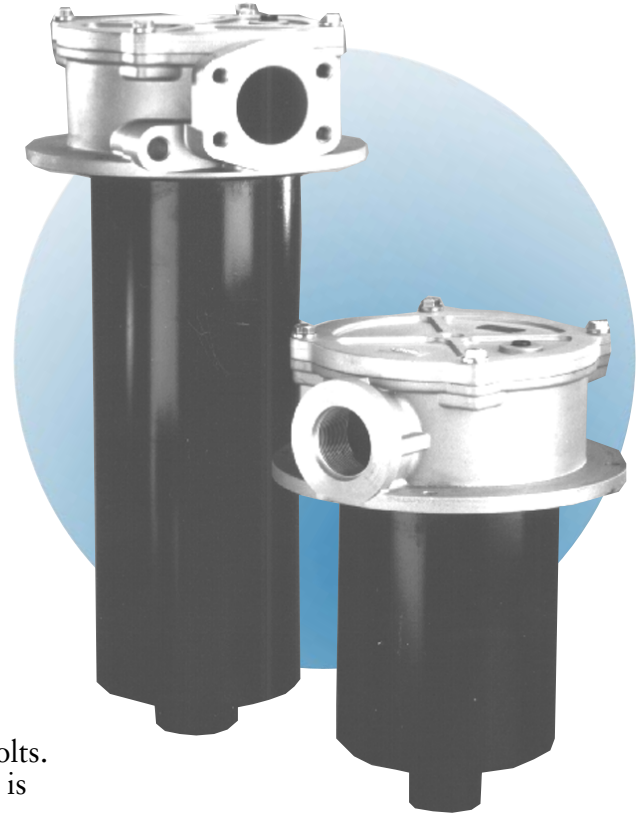

Features

Space-saving FIK low-pressure filters have heavy-duty aluminum heads and secure to a reservoir top by 2 or 4 bolts. Steel canisters provide maximum durability. Element flow is outside to inside.

Each of the five FIK standard assemblies contains a cartridge made with cellulose filter media rated at $\beta_{10}=75$. Replacement cartridges are offered in a range of media types and performance ratings.

Three service indicators are available optionally — pressure gauge, visual indicator and electrical indicator.

Beta Rating

- Performance to $\beta_{10}=75$

Porting Sizes

- SAE-16, -20, -24 O-Ring
- 2" SAE 4-Bolt Flange

Length

- 5 sizes, ranging from 8.5" / 216mm to 20" / 510mm

Standard Bypass Rating

- 22 *psi* / 150 kPa / 1.5 bar

Operating Temperatures

- -4°F to 194°F / -20°C to 90°C

Element Collapse Ratings

- 145 *psid* / 1000 kPa / 10 bar

Assembly - Side View

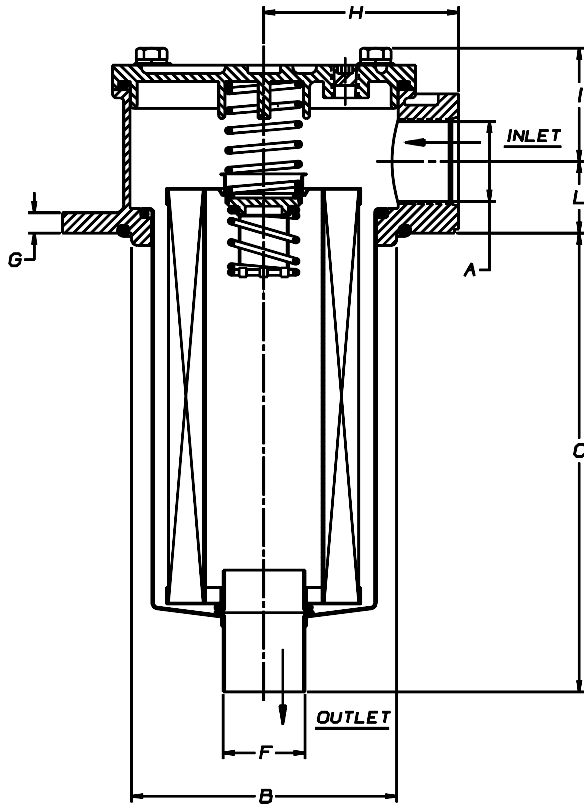

for:
 Cooling Circuits
 Process Systems
 Return-Line/Side-Loop
 Fluid Conditioning
 Lube Oil Systems
 Case Drains

FIK Model	K040799	K051204	K070248	K070249	K070250
A	1-inch SAE O-Ring	1 1/4-inch SAE O-Ring	1 1/2-inch SAE O-Ring	2-inch SAE 4-bolt flange	2-inch SAE 4-bolt flange
B	3.54 in. 90 mm	5.2 in. 131 mm	6.9 in. 175 mm	6.8 in. 174 mm	6.8 in. 174 mm
C	5.7 in. 145 mm	9 in. 230 mm	9.5 in. 242 mm	11.7 in. 297 mm	15.9 in. 405 mm
D	4.52 in. 115 mm	6.9 in. 175 mm	8.66 in. 220 mm	8.66 in. 220 mm	8.66 in. 220 mm
E	0.33 in. 8.4 mm	0.4 in. 10.5 mm	0.4 in. 10.5 mm	0.4 in. 10.5 mm	0.4 in. 10.5 mm
F	1.1 in. 28 mm	1.57 in. 40 mm	1.97 in. 50 mm	2.5 in. 63.5 mm	2.5 in. 63.5 mm
G	0.4 in. 10 mm	0.4 in. 10 mm	0.4 in. 10 mm	0.4 in. 10 mm	0.4 in. 10 mm
H	2.6 in. 66 mm	3.7 in. 95 mm	4.7 in. 119 mm	4.7 in. 119 mm	4.7 in. 119 mm
I	1.7 in. 43 mm	2.1 in. 53 mm	2.5 in. 64 mm	2.5 in. 64 mm	2.5 in. 64 mm
L	1.1 in. 28 mm	1.4 in. 35 mm	1.6 in. 41 mm	1.6 in. 41 mm	1.6 in. 41 mm
Weight	2.1 lbs .95 kg	7.0 lbs 3.2 kg	10.0 lbs 4.5 kg	13.1 lbs 5.9 kg	18.6 lbs 8.4 kg

Head - Top View

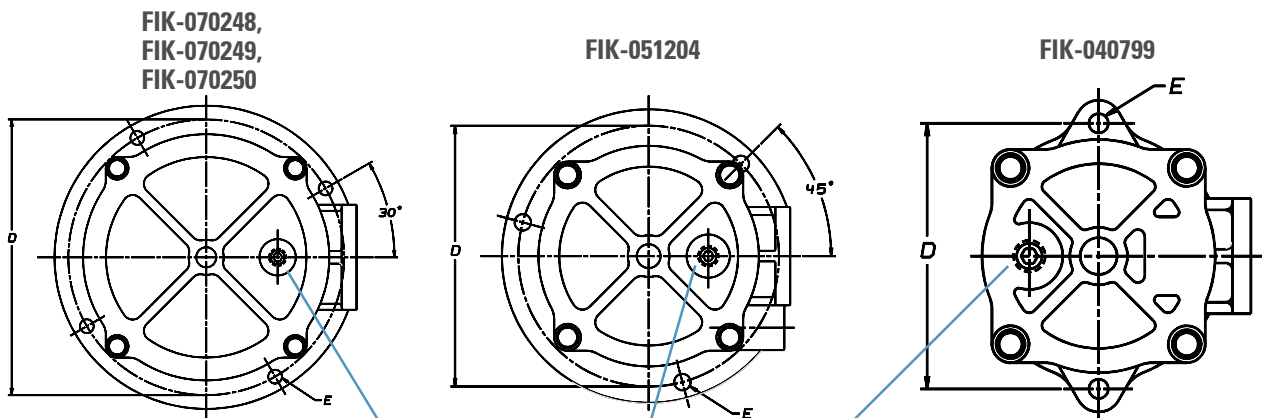

Port for Service Indicator (1/8" - 19 BSP)

All dimensions above are shown in inches [millimeters]

FIK Components



Service Indicator Options

Pressure Gauge P171953

-14.5 to 72 *psi*
-1 to +5 bar



Visual Indicator P171958

17 *psi*
1.2 bar



AC/DC Electrical Indicator P171966

17 *psi*
1.2 bar

In-Stock FIK Models

Port Size	Bypass Rating	Service Indicator	Beta Rating	FIK Assembly Model	Standard Service Element
1" SAE O-Ring	22 psi 1.5 bar	Port Available	$\beta_{10}=2$	K040799	P171533
1¼" SAE O-Ring				K051204	P171539
1½" SAE O-Ring				K070248	P171557
2" SAE 4-Bolt Flange				K070249	P171575
	K070250	P171581			

Replacement Element Choices

Media Technology	Beta Rating	-----Element Part Numbers per FIK Model-----				
		K040799	K051204	K070248	K070249	K070250
Synthetic	$\beta_{10}=75$	P171531	P171537	P171555	P171573	P171579
Synthetic	$\beta_{25}=75$	P171532	P171538	P171556	P171574	P171580
Cellulose	$\beta_{10}=2$	P171533	P171539	P171557	P171575	P171581
Cellulose	$\beta_{25}=2$	P171534	P171540	P171558	P171576	P171582
Wiremesh	60 Absolute	P171535	P171541			P171583
Wiremesh	90 Absolute	P171530	P171536		P171572	

Performance Data

For a full explanation of how our performance curves were derived, see page 100.

K040799 Assembly

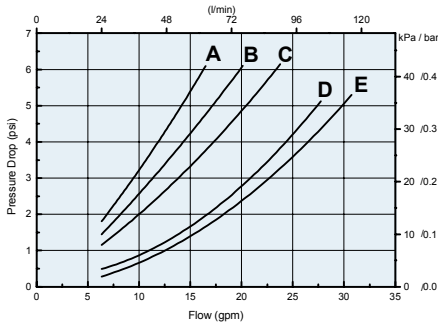

- Service Element Part Numbers
- A. P171531 (Synthetic)
 - B. P171532 (Synthetic)
 - C. P171533* (Cellulose)
 - D. P171534 (Cellulose)
 - E. P171535, P171530 (Wiremesh)

K051204 Assembly

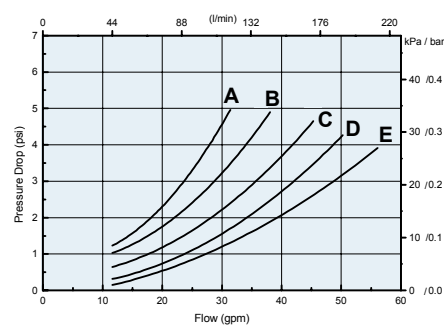

- Service Element Part Numbers
- A. P171537 (Synthetic)
 - B. P171538 (Synthetic)
 - C. P171539* (Cellulose)
 - D. P171540 (Hvy Duty Cellulose)
 - E. P171541, P171536 (Wiremesh)

K070249 Assembly

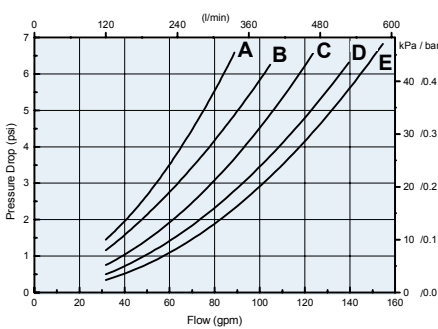

- Service Element Part Numbers
- A. P171573 (Synthetic)
 - B. P171574 (Synthetic)
 - C. P171575* (Cellulose)
 - D. P171576 (Cellulose)
 - E. P171572 (Wiremesh)

K070250 Assembly

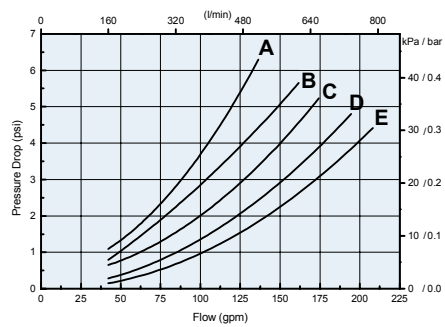

- Service Element Part Numbers
- A. P171579 (Synthetic)
 - B. P171580 (Synthetic)
 - C. P171581* (Cellulose)
 - D. P171582 (Cellulose)
 - E. P171583 (Wiremesh)

K070248 Assembly

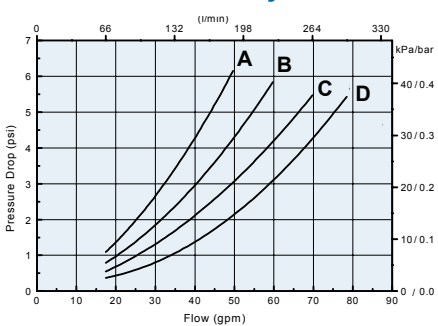

- Service Element Part Numbers
- A. P171555 (Synthetic)
 - B. P171556 (Synthetic)
 - C. P171557* (Cellulose)
 - D. P171558 (Cellulose)