



Magnaloy is the original lightweight, heavy-duty flexible drive coupling. Light weight magnesium construction makes Magnaloy couplings 76% lighter than cast iron and 36% lighter than aluminum units... and they're stronger than either!

The benefits are many... Reduced loads on bearings, shafts and pumps, for longer component life. Easier handling and installation. Rust proof and corrosion resistant.

Magnaloy's close machining tolerances (TIR of .002") assures vibration - free operation and easy, accurate alignment without need for special tools. Solid magnesium alloy permanent mold castings are heat treated and offer the highest strength-to-weight ratio available.

Coupling Performance Specifications

Coupling Model	Maximum Bore	Wr ² lb.- ft. ²	Insert Number	Rated Torque lb.- in.	Torsional Rigidity lb-in/Deg	Horse Power Rating@		
						100 rpm	1200 rpm	1800 rpm
100	1-1/8	.0046	170N	340.7	42	.55	6.5	9.8
			170U	511.0	53	.82	9.8	14.7
			170H	1,022.1	182	1.65	19.8	29.7
200	1-3/8	.0068	270N	398.3	55	.64	7.6	11.5
			270U	597.4	68	.96	11.5	17.2
			270H	1,194.9	234	1.92	23.0	34.5
300	1-5/8	.022	370N	701.4	81	1.12	13.5	20.2
			370U	1,052.1	148	1.68	20.2	30.3
			370H	2,104.2	336	3.36	40.4	60.6
400	1-7/8	.031	470N	1,056.3	138	1.69	20.3	30.4
			470U	1,584.5	310	2.5	30.4	45.6
			470H	3,168.9	488	5.1	60.8	91.3
500	2-3/8	.071	570N	2,194.8	314	3.5	42.1	63.2
			570U	3,292.2	695	5.3	63.2	94.8
			570H	6,584.4	1,571	10.5	126.4	189.6
600	2-5/8	.16	670N	4,946.7	676	7.9	94.9	142.5
			670U	7,420.1	1,510	11.9	142.5	213.7
			670H	14,840.1	2,960	23.7	284.9	427.4
700	2-7/8	.34	770N	11,639.8	1,805	18.6	223.5	335.2
			770U	17,459.7	2,104	27.9	335.2	502.8
			770H	29,099.5	-	46.5	558.75	838.0
800	3-7/8	.95	870N	21,889.4	3,680	35.0	420.3	630.4
			870U	32,834.1	-	52.5	630.4	945.6
			870H	47,062.2	-	75.2	903.0	1,354.5
900	4-3/4	4.20	970N	47,842.3	8,428	76.5	918.6	1,377.9
			970U	71,763.5	-	114.8	1,377.9	2,066.8

Magnaloy Coupling Dimensional Specifications

Models 100, 200, 300, 400

	100	200	300	400
A	2.54	3.10	3.58	4.24
B	2.600	2.900	3.450	3.980
C	2.00	2.25	2.90	3.05
D	0.56	0.68	0.78	1.00
E	0.68	0.84	0.96	1.06
F	0.42	0.42	0.44	0.54
G	0.31	0.43	0.56	0.73
W	1/16	1/16	1/16	1/16
X	0.90	0.90	0.98	1.20
T	1/4-20	5/16-18	5/16-18	3/8-16

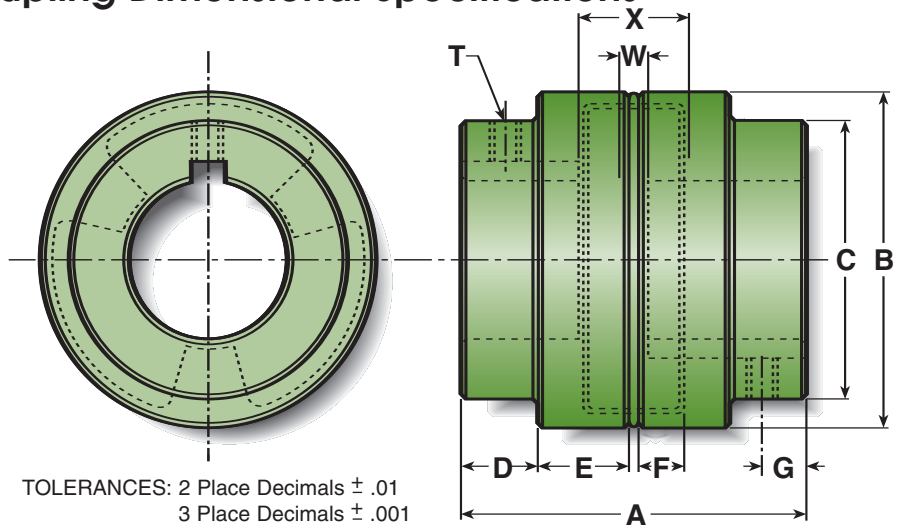

Model 500

	500
A	4.67
B	4.800
C	4.00
D	1.04
E	1.23
F	0.64
G	0.70
W	1/16
X	1.41
T	3/8-16

X*: Maximum Space between shaft ends to allow full shaft engagement in Hub Bore.

W*: Minimum spacing between shaft ends.

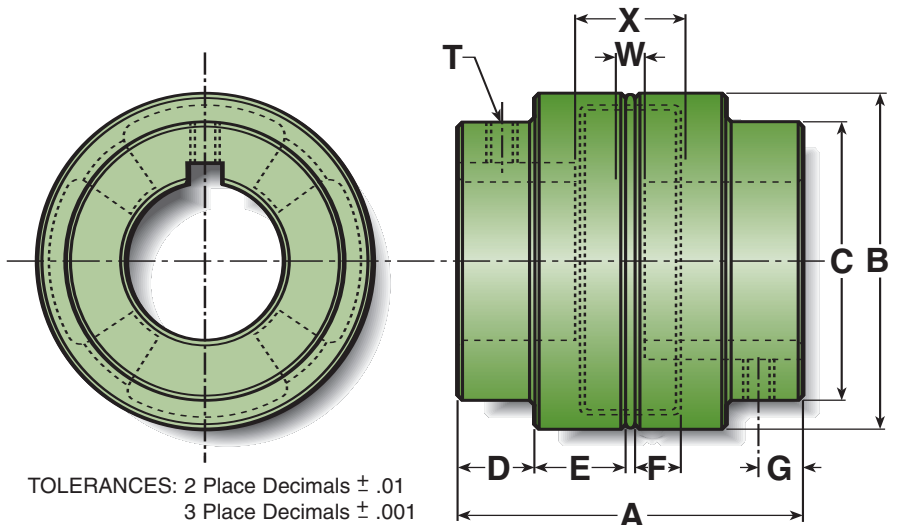

* Given for reference only.

Models 600, 700, 800, 900

	600	700	800	900
A	5.98	6.99	7.99	10.15
B	5.975	6.900	8.600	11.400
C	4.50	5.19	7.00	8.30
D	1.60	2.08	2.25	2.75
E	1.33	1.32	1.62	2.20
F	0.62	0.89	1.00	1.32
G	1.13	1.13	1.58	1.88
W	1/16	1/16	1/16	1/16
X	1.36	1.97	2.25	2.89
T	3/8-16	1/2-13	1/2-13	3/4-10

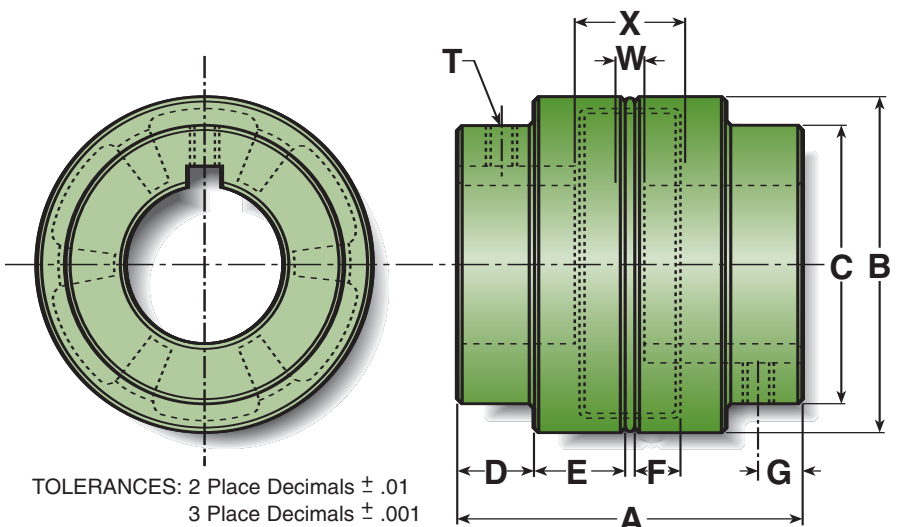

Standard Bore and Keyway Combinations

Magnaloy "Standard" Bore & Key Combinations												
Model Code	Bore/Key Code	Model →		100	200	300	400	500	600	700	800	900
		Bore	Key									
M	01203	3/8 x 3/32		•	•							
M	01403	7/16 x 3/32		•	•							
M	01404	7/16 x 1/8		•	•							
M	01604	1/2 x 1/8		•	•	•						
M	01804	9/16 x 1/8		•	•	•						
M	02005	5/8 x 5/32		•	•	•						
M	02006	5/8 x 3/16		•	•	•						
M	02206	11/16 x 3/16		•	•	•	•					
M	02404	3/4 x 1/8		•	•	•						
M	02406	3/4 x 3/16		•	•	•	•	•				
M	02806	7/8 x 3/16		•	•	•	•	•	•			
M	02808	7/8 x 1/4		•	•	•	•	•				
M	03008	15/16 x 1/4		•	•	•						
M	10006	1 x 3/16		•	•	•	•	•				
M	10008	1 x 1/4		•	•	•	•	•				
M	10408	1 1/8 x 1/4		•	•	•	•	•				
M	10608	1 3/16 x 1/4				•		•				
M	10808	1 1/4 x 1/4			•	•	•	•				
M	10810	1 1/4 x 5/16			•	•	•	•	•			
M	11210	1 3/8 x 5/16			•	•	•	•	•			
M	11212	1 3/8 x 3/8				•						
M	11412	1 7/16 x 3/8				•	•	•				
M	11610	1 1/2 x 5/16					•	•				
M	11612	1 1/2 x 3/8				•	•	•	•			
M	12012	1 5/8 x 3/8				•	•	•	•	•		
M	12412	1 3/4 x 3/8					•	•	•	•		

Magnaloy "Standard" Bore & Key Combinations												
Model Code	Bore/Key Code	Model →		100	200	300	400	500	600	700	800	900
		Bore	Key									
M	12414	1 3/4 x 7/16						•	•	•	•	•
M	12816	1 7/8 x 1/2						•	•	•	•	•
M	13016	1 15/16 x 1/2							•	•		
M	20016	2 x 1/2							•	•	•	•
M	20416	2 1/8 x 1/2							•	•	•	•
M	20816	2 1/4 x 1/2							•	•	•	•
M	21220	2 3/8 x 5/8							•	•	•	•
M	21620	2 1/2 x 5/8								•	•	•
M	22020	2 5/8 x 5/8								•	•	•
M	22420	2 3/4 x 5/8									•	•
M	22824	2 7/8 x 3/4									•	•
M	30024	3 x 3/4										•
M	30824	3 1/4 x 3/4										•
M	31228	3 3/8 x 7/8										•
M	31628	3 1/2 x 7/8										•
M	32028	3 5/8 x 7/8										•
M	32428	3 3/4 x 7/8										•
M	32832	3 7/8 x 1										•
M	40032	4 x 1										•
M	40432	4 1/8 x 1										•
M	40832	4 1/4 x 1										•
M	41232	4 3/8 x 1										•
M	41632	4 1/2 x 1										•
M	41640	4 1/2 x 1 1/4										•
M	42040	4 5/8 x 1 1/4										•
M	42440	4 3/4 x 1 1/4										•

Shaded Area: AGMA semi-standard bore key combinations.

Part Number Usage: Magnaloy Coupling Hub part numbers may be specified using the following format: Start with letter "M" designating Magnaloy, followed by 3 digit Model Code (100, 200, etc.), then the specific 5 digit Bore Key Code.

Example: Model 500 hub with a 1 3/8 bore and 5/16 keyway would be specified as: M50011210 - No bore hubs are designated as 'R' code, ie: M500R.

Bore Tolerances

Over	Include	Tolerance
--	1	+0.0008/ +0.0003
1	2	+0.0013/ +0.0005
2	3	+0.0018/ +0.0008
3	4	+0.0020/ +0.0010
4	5	+0.0023/ +0.0010

Additional Coupling Specifications

Model Number	100	200	300	400	500	600	700	800	900
Maximum Bore	1-1/8	1-3/8	1-5/8	1-7/8	2-3/8	2-5/8	2-7/8	3-7/8	4-3/4
Complete Coupling Approx. Wght. (Solid Hub)	3/4	1	2	3	4	7	12	18	38
Number of Drive Lugs	3	3	3	3	4	6	6	6	6
Hub Movement for Insert Removal	.74	.74	.75	.98	1.12	1.02	1.50	1.63	2.27
Basic Insert Number	170	270	370	470	570	670	770	870	970