

LIQUID LEVEL GAGE - FRONT MOUNT, CARD THERMOMETER

Low profile body with wide sight openings is machined from extruded aluminum bar stock NOT a composite of a stamping and molded plastic parts. Gage may be mounted from front if reservoir wall is heavy enough to tap for mounting bolt. Otherwise use nuts furnished on 1/2-20 and 1/2-13 mountings to tighten on interior wall of reservoir. Furnished complete with all O-ring seals and nuts. A .06 (1.52mm) alignment adjustment at each end facilitates mounting. 3.00 (76.20mm) centerline gage has 60°F (15.6°C) to 180°F (82.2°C) thermometer scale, 5.00 (127.00mm) and longer centerline gage has 0°F to 220°F (104.4°C) thermometer scale.

STANDARD MATERIALS:

- Aluminum construction
- Buna N seals
- Crystal clear borosilicate sight for maximum fluid compatibility and will not discolor with time or temperature

OPERATING CONDITIONS:

- Maximum working pressure up to 20 PSI (137.9 kPa) at 150°F (65.6°C), no corrosion

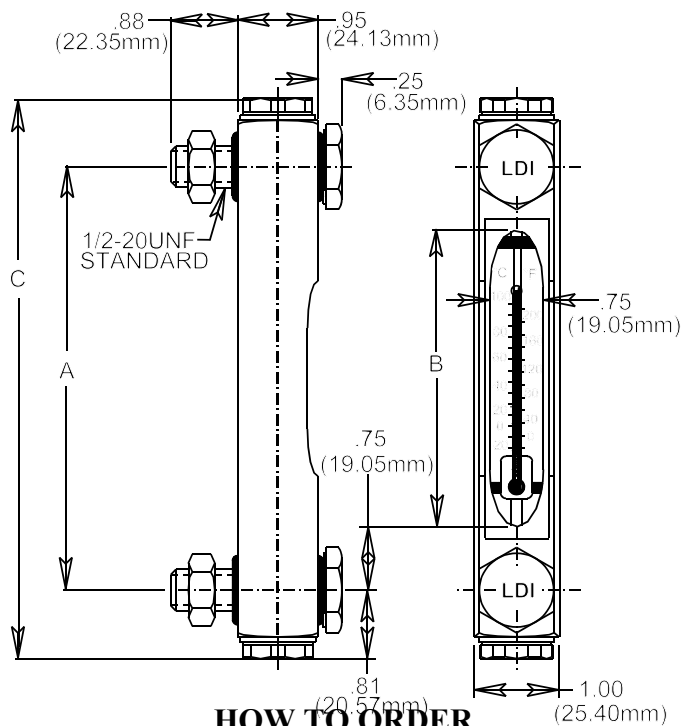

HOW TO ORDER

Select catalog number as shown:

EXAMPLE:

G1615-10-A-1 — Buna N seals (standard)
 — Aluminum construction only
 — 10.00 (254.00mm) centers
 — Gage series

OPTIONS:

- **EPDM SEALS** - Specify -4 in place of -1 or -3 in catalog number.
- **1/2-13 COARSE THREAD FOR MOUNTING** - Specify "C" after the seal number.
- **M12 x 1.75 THREAD FOR MOUNTING** - Specify "M" after seal number.
- **CONTACT FACTORY FOR AVAILABILITY & PRICE ON BLUE FLUID IN THERMOMETER** - Specify "B" after seal number. (Not available for 3.00 [76.20mm] centers.)

BUNA N SEALS			
CATALOG NUMBER	A CENTERS INCHES (mm)	B SIGHT INCHES (mm)	C LENGTH INCHES (mm)
G1615-03-A-1	3.00 (76.20)	1.50 (38.10)	4.62 (117.35)
G1615-05-A-1	5.00 (127.00)	3.50 (88.90)	6.62 (168.15)
G1615-10-A-1	10.00 (254.00)	8.50 (215.90)	11.62 (295.15)
VITON A® SEALS			
G1615-03-A-3	3.00 (76.20)	1.50 (38.10)	4.62 (117.35)
G1615-05-A-3	5.00 (127.00)	3.50 (88.90)	6.62 (168.15)
G1615-10-A-3	10.00 (254.00)	8.50 (215.90)	11.62 (295.15)



LUBE DEVICES, INC.

1864 NAGLE AVE., P.O. BOX 1810, MANITOWOC, WI 54221-1810
 PHONE: (920) 682-6877 FAX: (920) 684-7210
 E-MAIL: sales@lubedevices.com WEBSITE: www.lubedevices.com

LIQUID LEVEL GAGE - FRONT MOUNT, CARD THERMOMETER

3/04 BULLETIN F327-1615