

Closed center, flow divider-combiner valve

Capacity:
1.5 - 8 gpm (6 - 32
L/min.)

Functional Group:
Products : Cartridges : Flow Divider : Divider/Combiner : Closed
Center

Model:
FSCA-XAN

Product Description

Closed-center flow divider/combiners are sliding-spool, pressure-compensated devices used to split flow in one direction and combine flow in the opposite direction. These valves may be used to accurately control two or more cylinders or hydraulic motors where bidirectional operation is required.

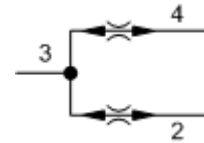

Download

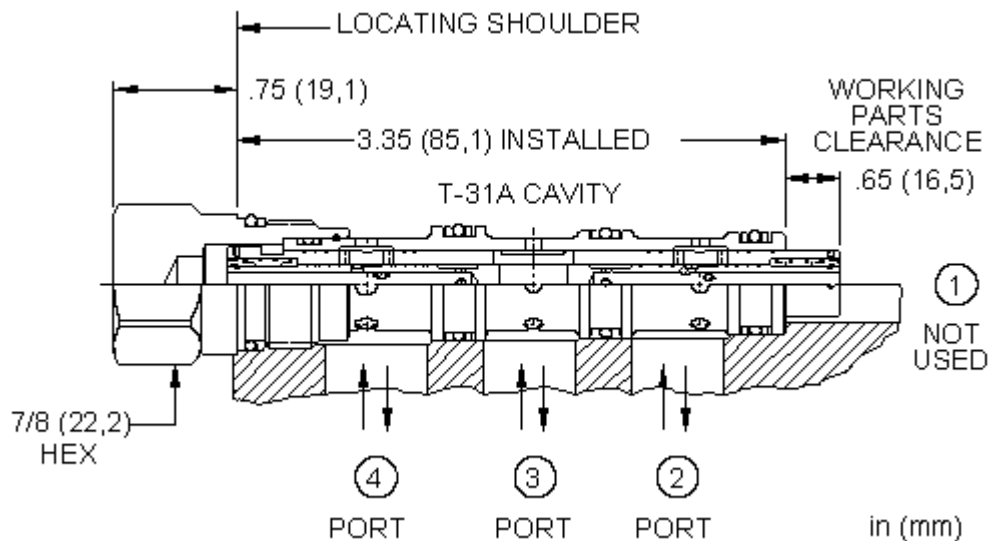

Technical Features

- Operating characteristics cause the leg of the circuit with the greatest load to receive the higher percentage of flow in dividing mode. If a rigid mechanism is used to tie actuators together, the lead actuator may pull the lagging actuator and cause it to cavitate.
- In applications involving rigid mechanisms between multiple actuators, operating inaccuracy will cause the eventual lock-up of the system. If the mechanical structure is not designed to allow for the operating inaccuracy inherent in the valve, damage may occur.
- Variations in speed and lock-up can be attributed to differences in motor displacement, motor leakage, wheel diameter variance and friction of wheels on the driving surface.
- Flow between ports is limited to spool leakage. This does not provide leak proof holding capability, but can be useful in minimizing cross flow and
- In combining mode, compensating characteristics will cause the leg of the circuit with the lowest load to receive the higher percentage of flow. If a synchronization feature is not included, an additive accuracy error will be experienced with each full stroke of the actuator.
- In motor circuits, rigid frames or mechanisms that tie motors together, and/or complete mechanical synchronized motion of the output shaft of the motors, either by wheels to the pavement or sprockets to conveyors, will contribute to cavitation, lock-up and/or pressure intensification.
- Extreme pressure intensification can occur on multiple wheel drive vehicles.
- Divisional and combining accuracy are equal.

drift.

- Below the minimum flow rating there is not enough flow for the valve to modulate. It is effectively a tee. If flow starts at zero and rises, there will be no dividing or combining control until the flow reaches the minimum rating.
- Incorporates the Sun floating style construction to minimize the possibility of internal parts binding due to excessive installation torque and/or cavity/cartridge machining variations.
- All flow divider and divider/combiner cartridges are physically interchangeable (i.e. same flow path, same cavity for a given frame size).

Technical Data

	U.S. Units	Metric Units
Model Weight	0.35 lb.	0.16 kg.
Cavity	T-31A	
Capacity	1.5 - 8 gpm	6 - 32 L/min.
Divisional Accuracy at Max Input Flow	50% ±2.5%	
Divisional Accuracy at Minimum Input Flow	50% ±4.5%	
Maximum Operating Pressure	5000 psi	350 bar
Pressure Drop at Maximum Rated Input Flow	350 psi	24 bar
Pressure Drop at Minimum Rated Input Flow	15 psi	1 bar
Series (from Cavity)	Series 1	
Valve Hex Size	7/8 in.	22,2 mm
Valve Installation Torque	30 - 35 lbf ft	45 - 50 Nm
Seal Kits	Buna: 990-031-007	
Seal Kits	Viton: 990-031-006	

Split	Input Flow		Rated Accuracy	Maximum Possible Flow Variation
	Max Rated			
50:50	Max Rated	8 gpm	±2.5%	3.80 - 4.20 gpm
		30 L/min		14,3 - 15,8 L/min
	Min rated	1.5 gpm	±4.5%	.68 - .82 gpm
		6 L/min		2,73 - 3,27 L/min

The maximum possible variation is at 5000 psi (350 bar) differential between legs with the high pressure leg being the higher flow in dividing mode and the lower flow in combining mode.

FSCA-XAN

Control

Flow Split

External Material/Seal Material

X Not Adjustable +0.00

A 50/50 +0.00

N Buna-N +0.00

