

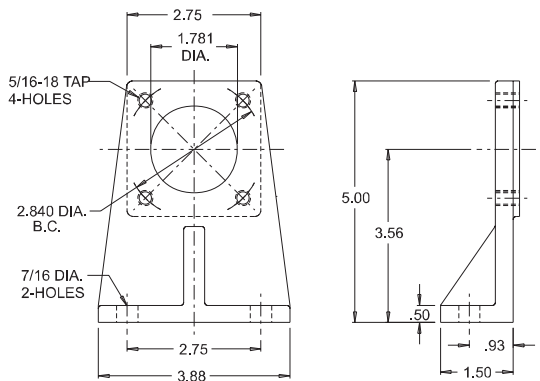

FOOT MOUNT BRACKETS



- For pumps and motors with USA/SAE mounting flanges
- Lightweight, high-strength aluminum casting
- Readily available from stock



Vescor Part Number	Description
FM100	USAF17 4-Bolt Foot Bracket

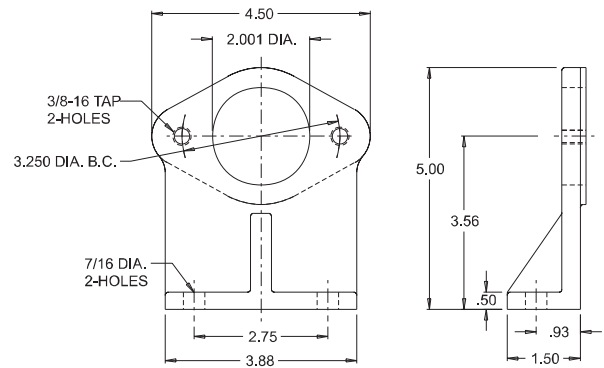

Vescor Part Number	Description
FM150	SAE AA 2-Bolt Foot Bracket

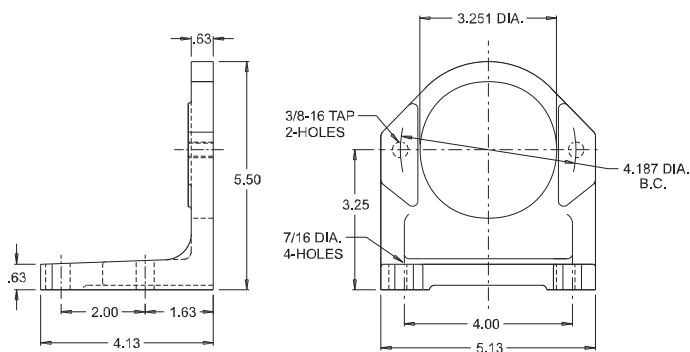

Vescor Part Number	Description
FM200	SAE A 2-Bolt Foot Bracket

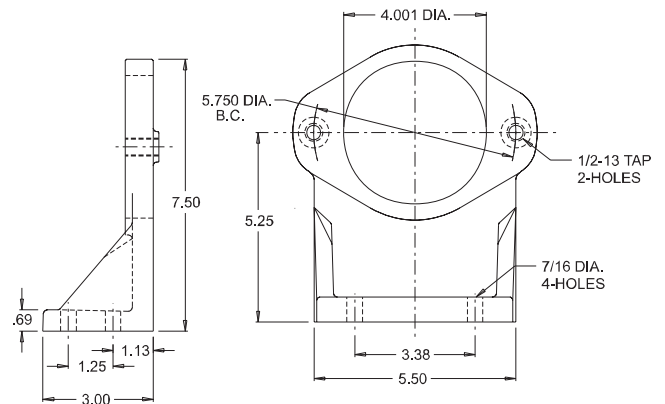

Vescor Part Number	Description
FM300	SAE B 2-Bolt Foot Bracket



2/4 BOLT FOOT MOUNT BRACKETS

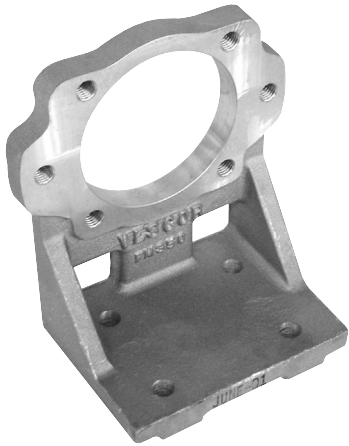

- For pumps and motors with SAE B (2) or (4) bolt mounting flanges
- Lightweight, high-strength aluminum casting
- Readily available from stock

Vescor Part Number	Description
FM350	SAE B 2/4-Bolt Foot Bracket

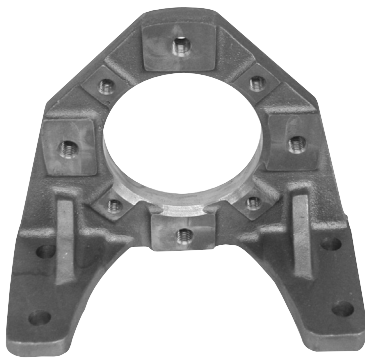
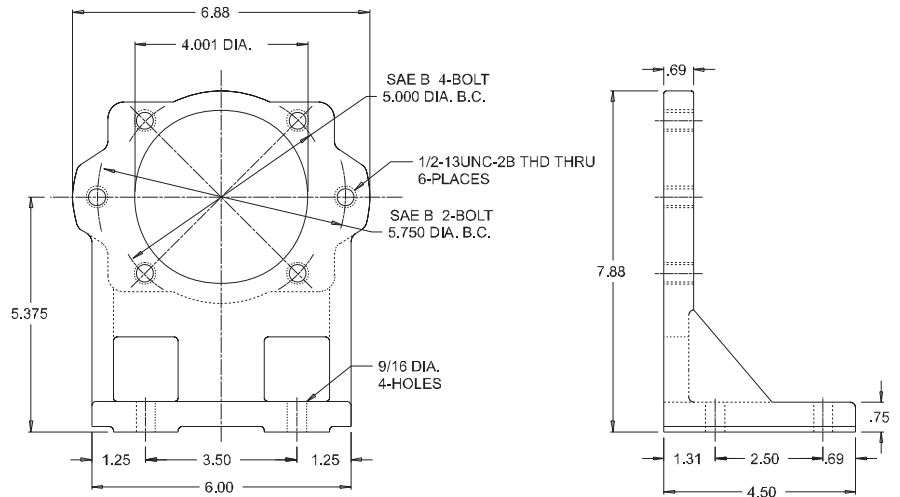

- For pumps and motors with SAE C (2) or (4) bolt mounting flanges
- Material Cast Iron
- Readily available from stock

Vescor Part Number	Description
FM400	SAE C 2/4-Bolt Foot Bracket

