

CONFIGURATION

/S Modifier 65-45-12 Ductile Iron, Buna-N, Blackened

TECHNICAL DATA

Body Type	Line mount
Interface	None
Body Features	Ninety degree
Mounting Hole Diameter	.34 in.
Mounting Hole Depth	Through
Mounting Hole Quantity	1
Open Cavities	1
Cavity	T-10A
Port Size	SAE 6
Model Weight	1.00 lb.

NOTES

Important: Carefully consider the maximum system pressure. The pressure rating of the manifold is dependent on the manifold material, with the port type/size a secondary consideration. Manifolds constructed of aluminum are not rated for pressures higher than 3000 psi (210 bar), regardless of the port type/size specified.

PORT DESIGNATORS

Modifiers	Ports
FAI, /S	All Ports: SAE 6;

CONFIGURATION OPTIONS
Model Code Example: FAI/S

MODIFIER _____ **(/S)**
/S 65-45-12 Ductile Iron, Buna-N, Blackened
 6061-T651 Aluminum, Buna-N

MANIFOLD FACES

FACE GRID



5	6	7	8
9	10	11	12

Face 2

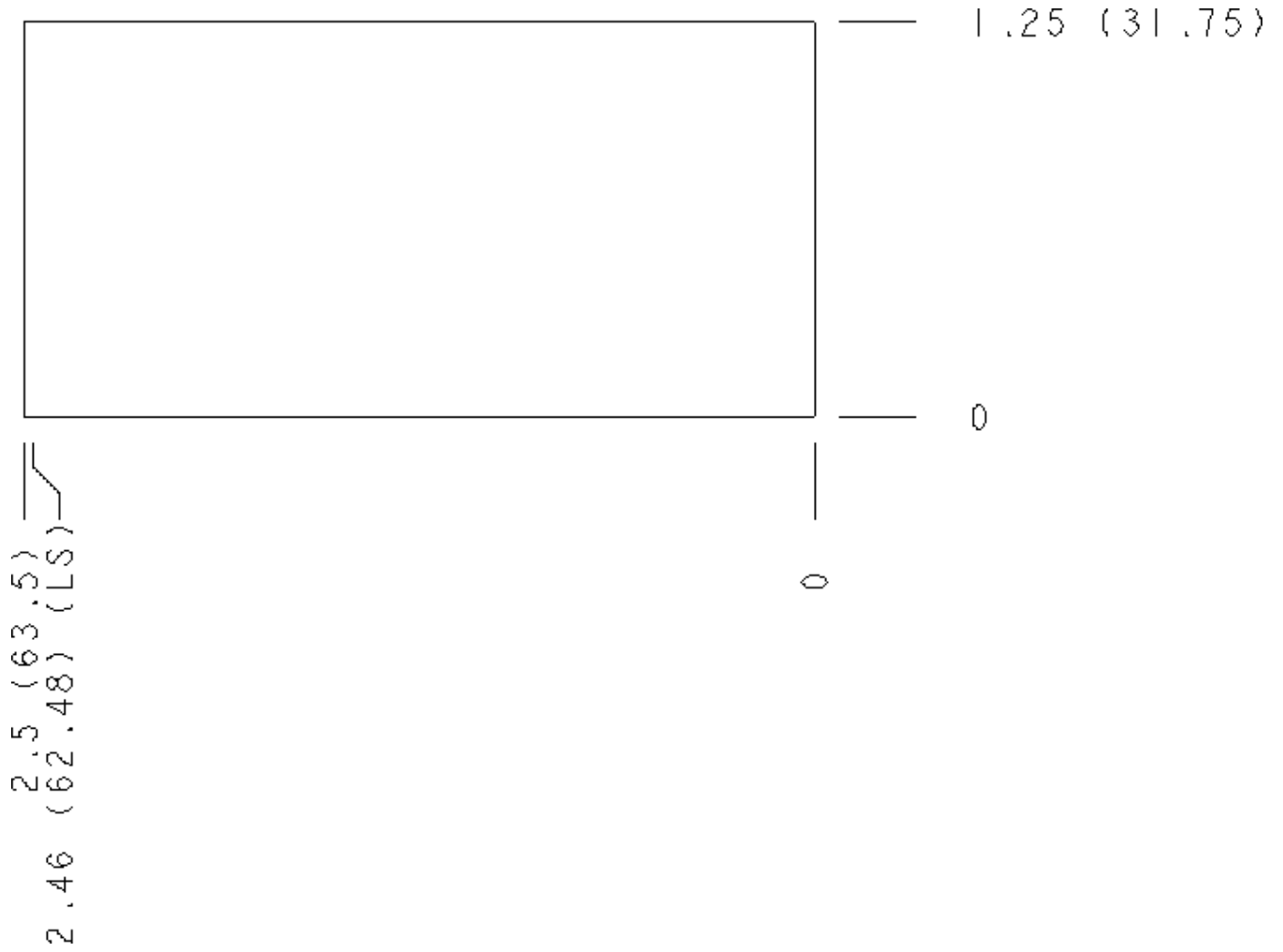

Face 5

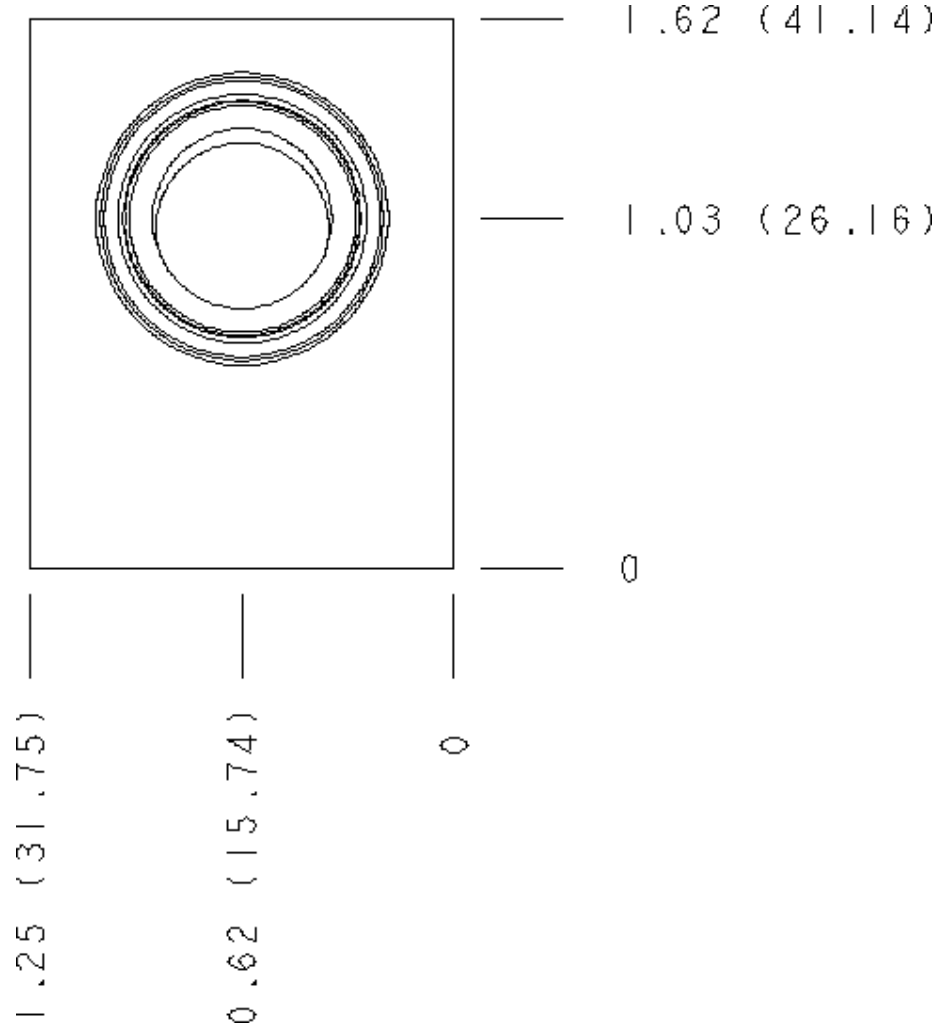

Face 6

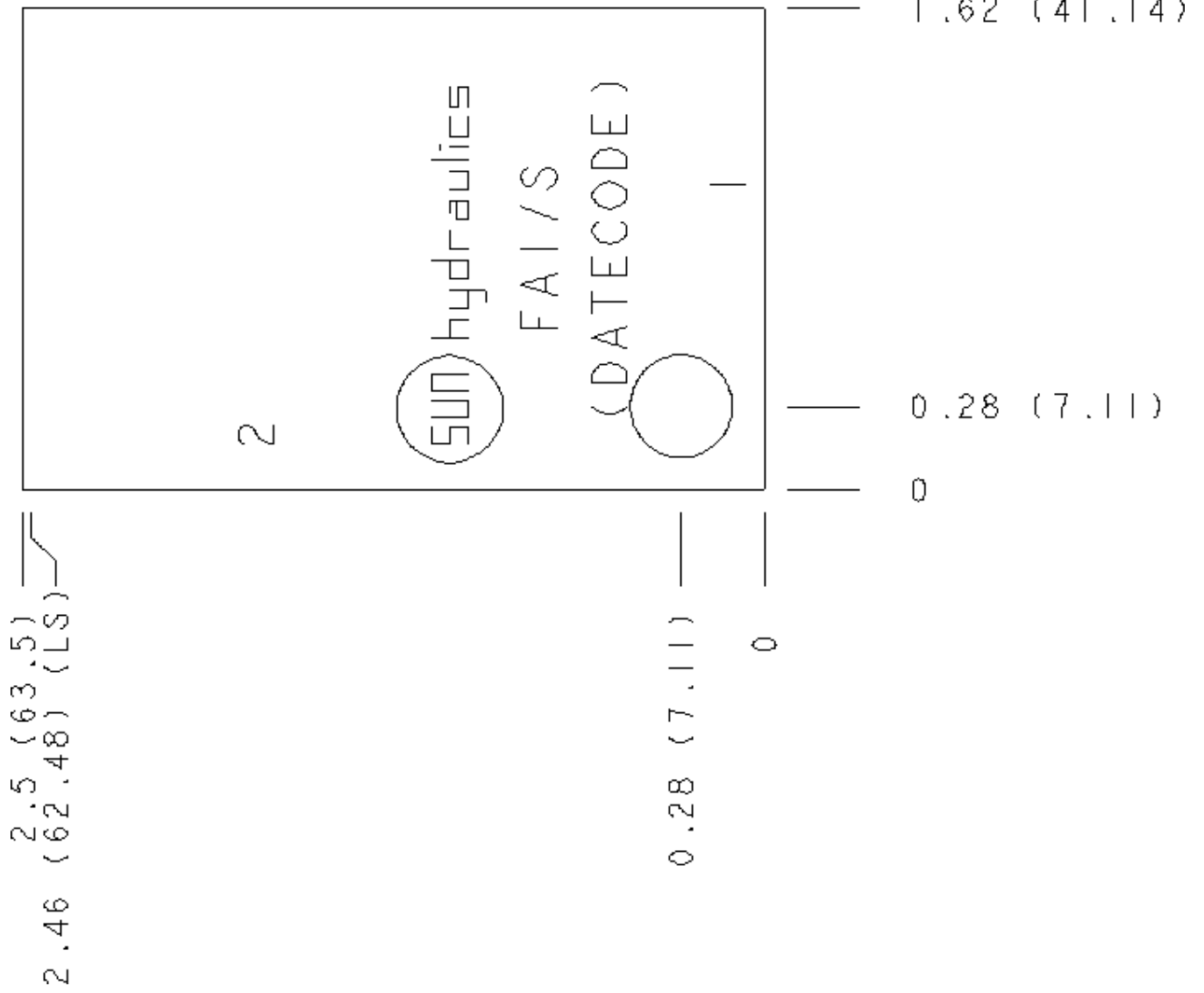

Face 7

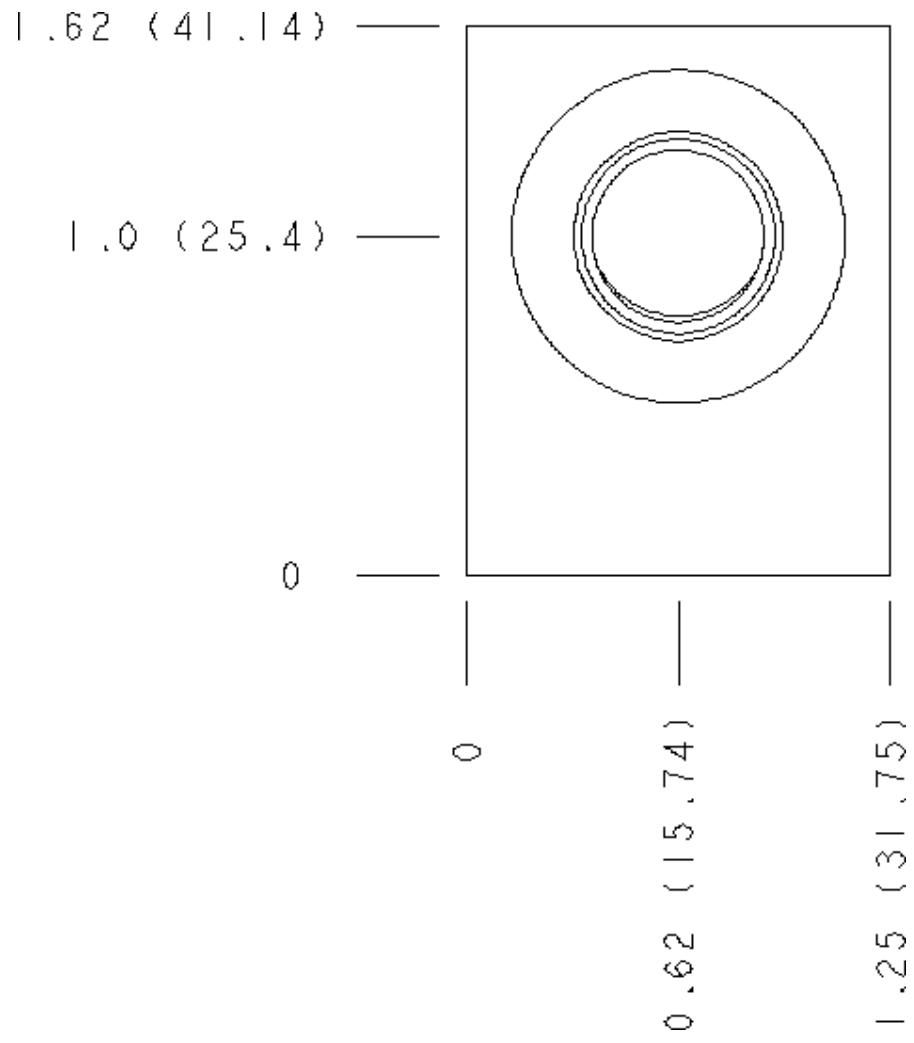

Face 8

1.62 (41.14)

0

0

2.46 (62.48) (LS)
2.5 (63.5)

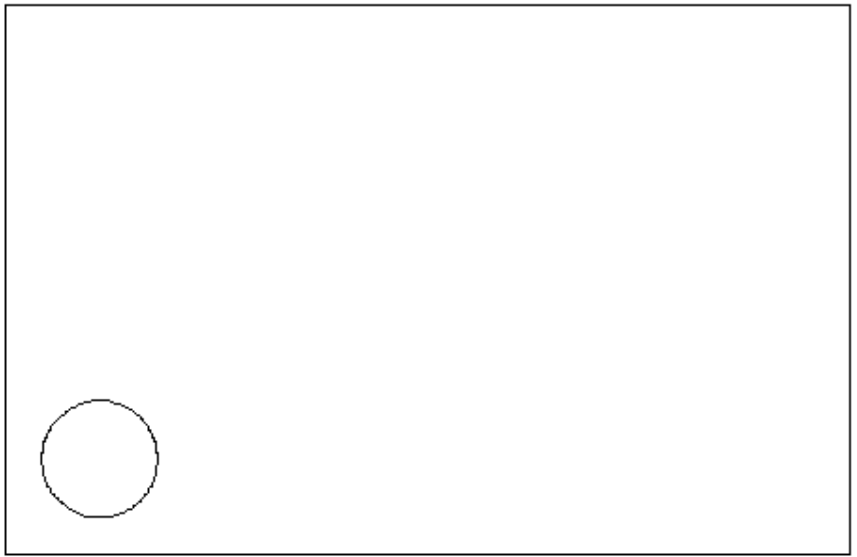

Face 10

