

CONFIGURATION

/S Modifier 65-45-12 Ductile Iron, Buna-N, Chem. Black

TECHNICAL DATA

Body Type	Line mount
Interface	None
Body Features	Ninety degree
Mounting Hole Diameter	.34 in.
Mounting Hole Depth	Through
Mounting Hole Quantity	2
Open Cavities	1
Cavity	T-11A
Port Size	SAE 8
Model Weight	1.86 lb.

NOTES

Important: Carefully consider the maximum system pressure. The pressure rating of the manifold is dependent on the manifold material, with the port type/size a secondary consideration. Manifolds constructed of aluminum are not rated for pressures higher than 3000 psi (210 bar), regardless of the port type/size specified.

PORT DESIGNATORS

Modifiers	Ports
ECJ, /10, /11, /S, /S3	Ports 1 & 2: SAE 8; Port 3: SAE 6;

CONFIGURATION OPTIONS

Model Code Example: ECJ/S

MODIFIER (S)

- /S** 65-45-12 Ductile Iron, Buna-N, Chem. Black
- 6061-T651 Aluminum, Buna-N
- /11** 6061-T651 Aluminum, Buna-N, Clear Anodize - Per MIL SPEC 8625F Type II, Class I
- /10** 6061-T651 Aluminum, Buna-N, Black Anodize - Per MIL SPEC 8625F Type II, Class II
- /S3** 65-45-12 Ductile Iron, Buna-N, Trivalent Clear Zinc with Top Sealer

MANIFOLD FACES

FACE GRID



5	6	7	8
9	10	11	12

Face 2

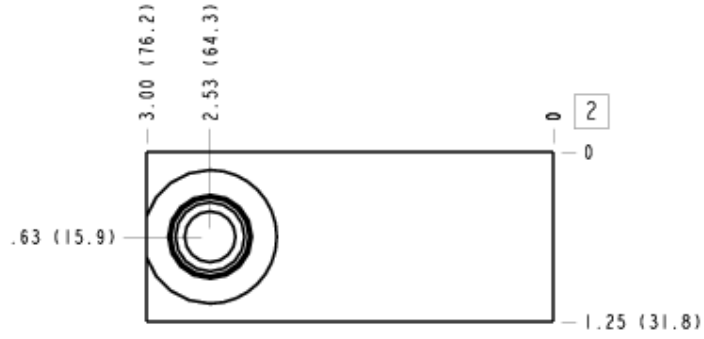

Face 5

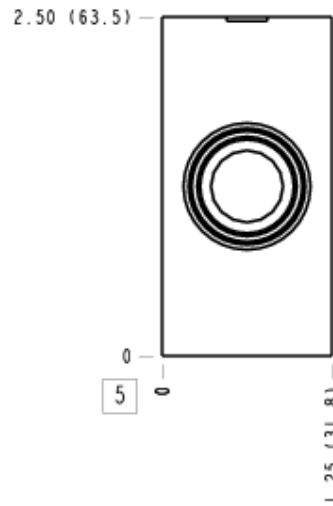

Face 6

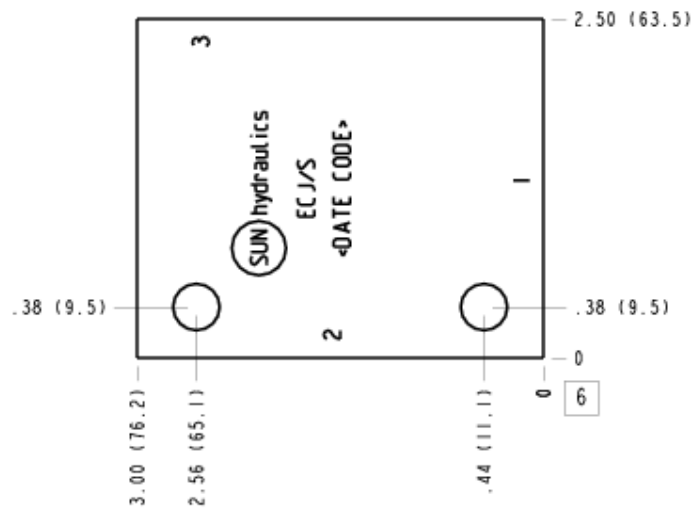

Face 7

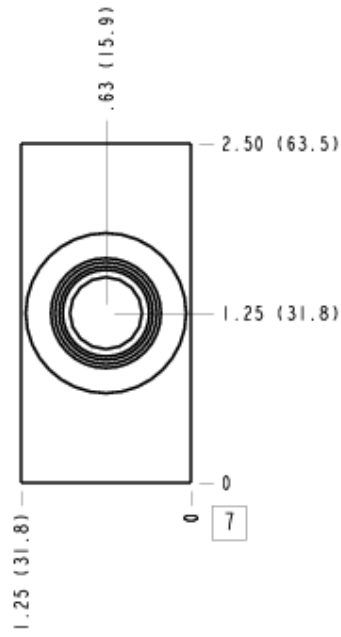

Face 10

