

Functional Group:

Products : Manifolds : Sandwich : Check : ISO 07 : On P

Model:

DKP

Face : 7

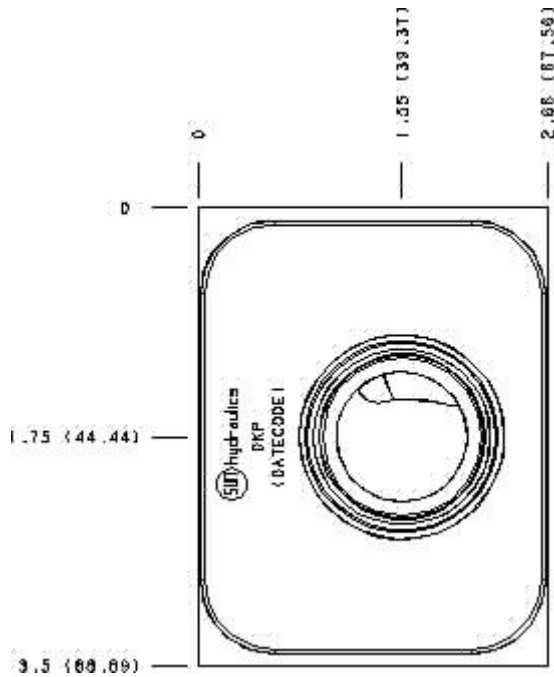

Cartridge extension measurement is to the centerline of the cartridge.

Function

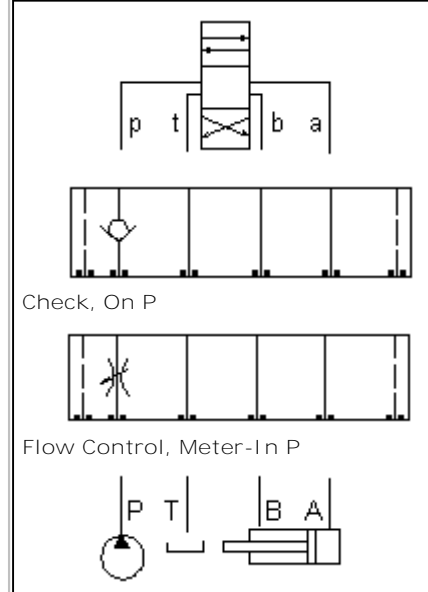

Aluminum Body Pressure Rating: **3000 psi (210 bar)**

Ductile Iron Body Pressure Rating: **5000 psi (350 bar)**

Technical Data

	U.S. Units	Metric Units
Model Weight	3.94 lb.	1.79 kg.
Cavity	T-16A	
Body Features	Into P	
Body Type	Sandwich	
Interface	ISO 07	
Open Cavity Quantity	1	
Stack Height	2.74 in.	70 mm

Option Selection:

Model Code	Description
DKP	Aluminum, Buna-N, U.S. Units
DKP/S	Ductile Iron, Buna-N, U.S. Units
DKP/V	Aluminum, Viton, U.S. Units
DKP/Y	Ductile Iron, Viton, U.S. Units

Special Notes :

- For check valve application, use only with CX*A check valves - free flow nose to side.



Functional Group:
Products : Manifolds : Sandwich : Check : ISO 07 : On P

Model:
DKP

Face : 2

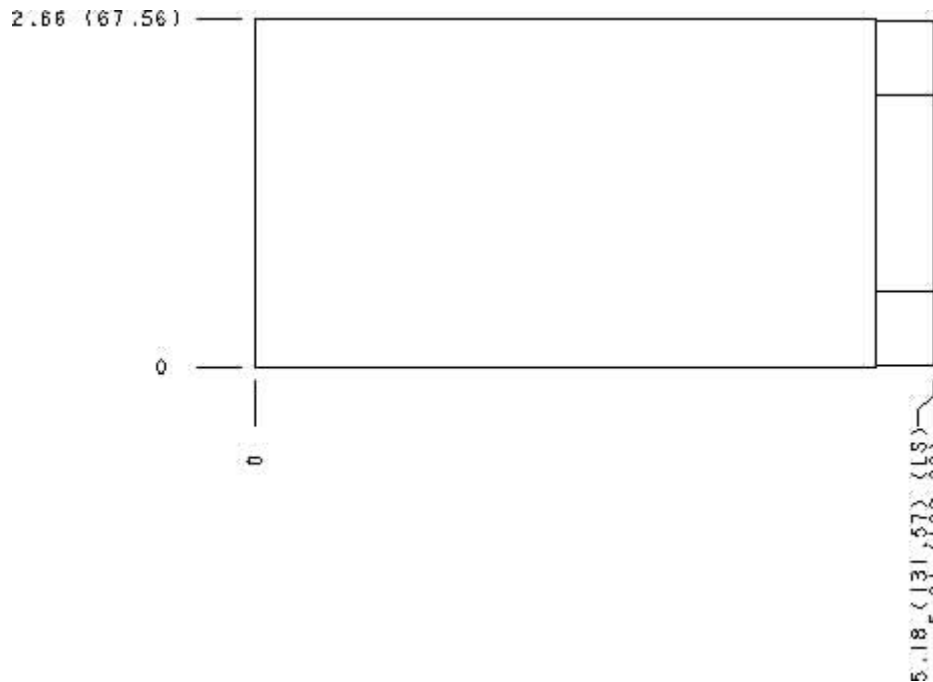

Cartridge extension measurement is to the centerline of the cartridge.



Face : 5

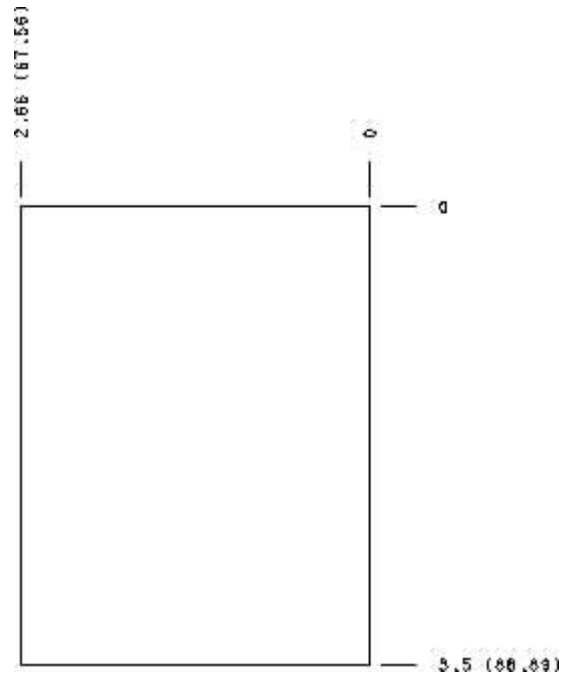

Cartridge extension measurement is to the centerline of the cartridge.



Face : 6

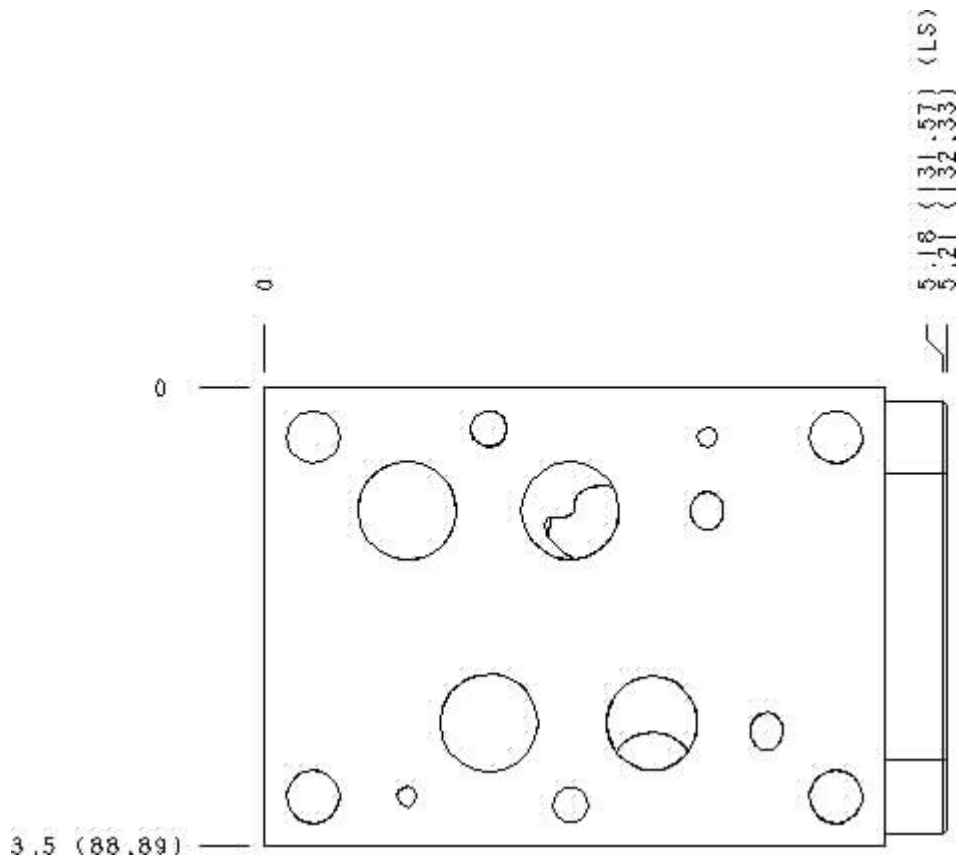

Cartridge extension measurement is to the centerline of the cartridge.



Functional Group:
 Products : Manifolds : Sandwich : Check : ISO 07 : On P

Model:
 DKP

Face : 8

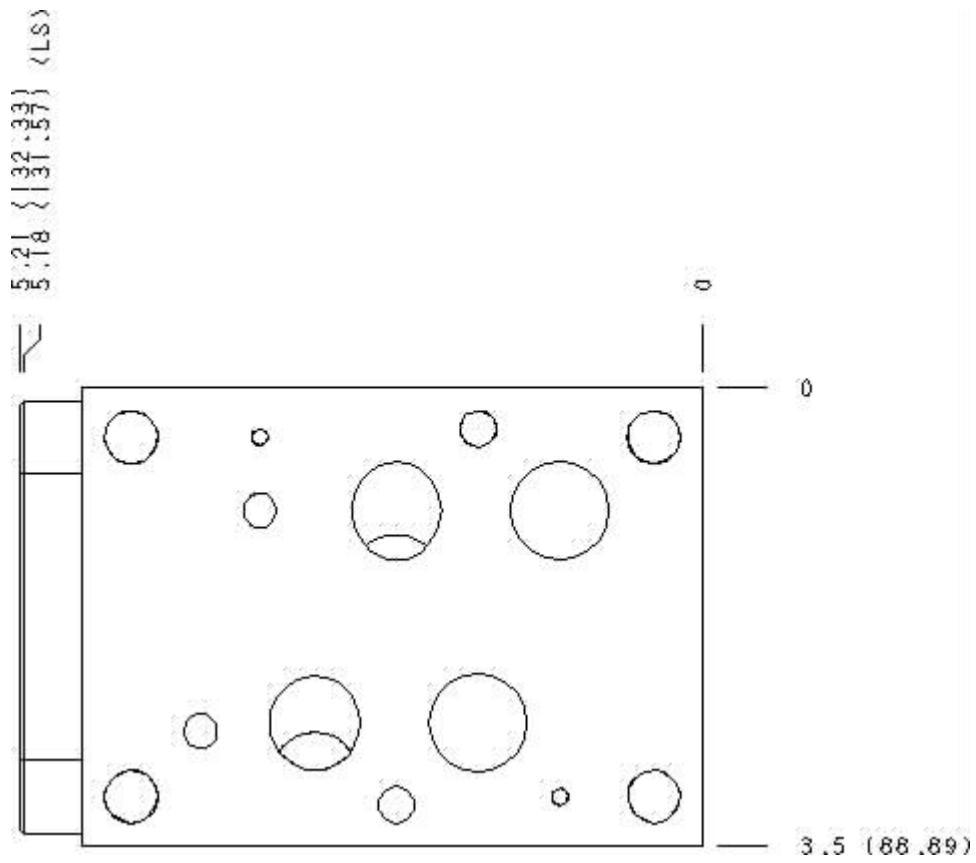

Cartridge extension measurement is to the centerline of the cartridge.



Functional Group:
 Products : Manifolds : Sandwich : Check : ISO 07 : On P

Model:
 DKP

Face : 10

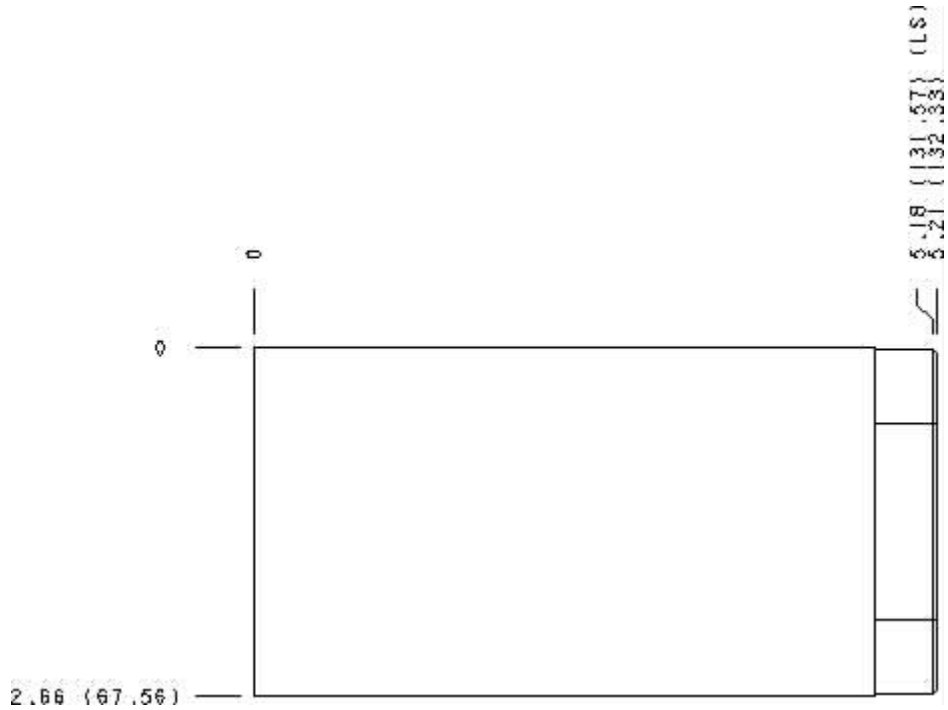

Cartridge extension measurement is to the centerline of the cartridge.



Functional Group:

Products : Manifolds : Sandwich : Check : ISO 07 : On P

Model:
DKP

Projection Type

All Dimensions in Inches(mm)

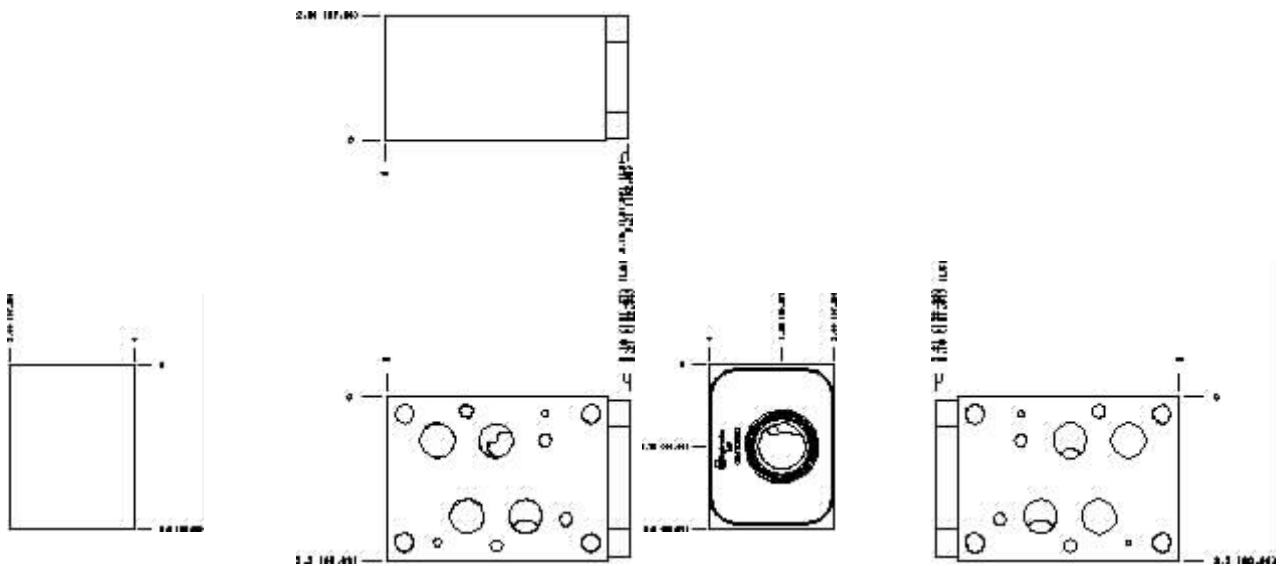

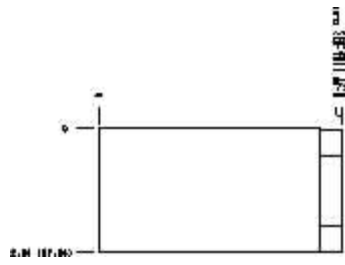

Copyright © 2007-2008 Sun Hydraulics Corporation.
All rights reserved.

[Terms and Conditions](#) - [Statement of Privacy](#)