

Functional Group:

Model:

Products : Manifolds : Sandwich : Flow Control : ISO 05 : Meter out T

DBT

Face : 6

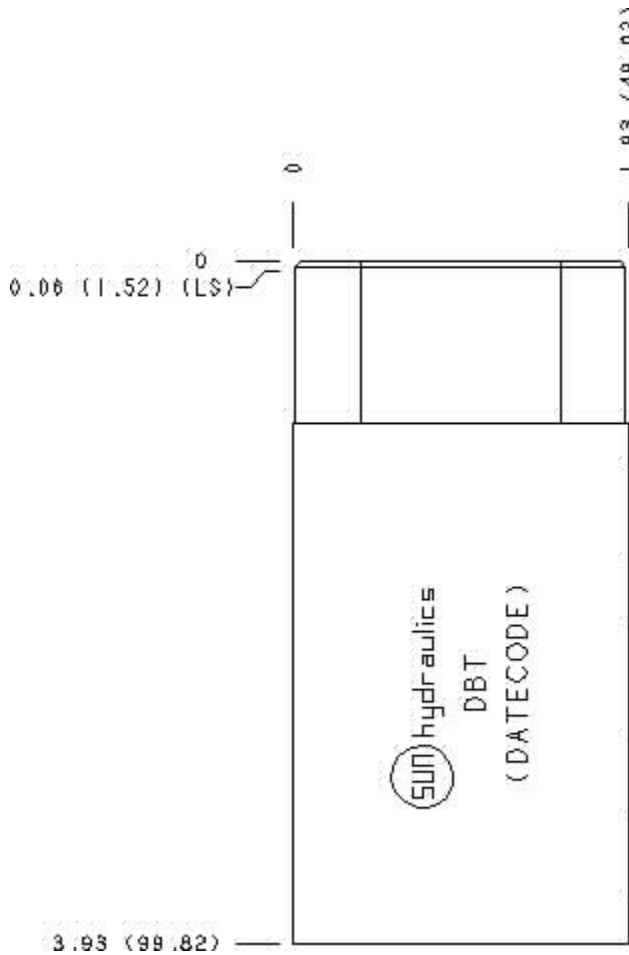

Cartridge extension measurement is to the centerline of the cartridge.

Function

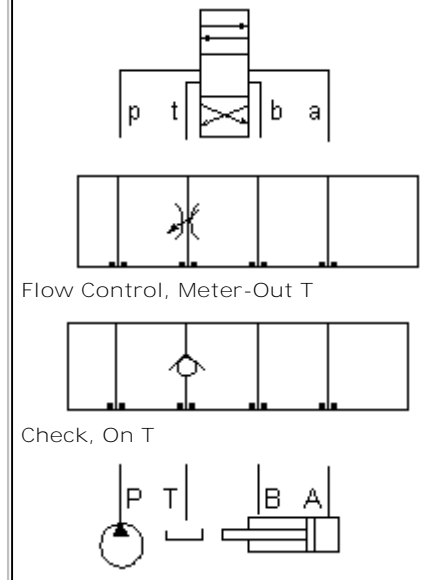

Flow Control, Meter-Out T

Check, On T

Aluminum Body Pressure Rating: **3000 psi (210 bar)**

Ductile Iron Body Pressure Rating: **5000 psi (350 bar)**

Technical Data

	U.S. Units	Metric Units
<b>Model Weight</b>	1.55 lb.	0.70 kg.
<b>Cavity</b>	T-5A	
<b>Body Features</b>	Out of T	
<b>Body Type</b>	Sandwich	
<b>Interface</b>	ISO 05	
<b>Open Cavity Quantity</b>	1	
<b>Stack Height</b>	1.94 in.	49 mm

---

Option Selection:

Model Code	Description
DBT	Aluminum, Buna-N, U.S. Units
DBT/S	Ductile Iron, Buna-N, U.S. Units
DBT/V	Aluminum, Viton, U.S. Units
DBT/Y	Ductile Iron, Viton, U.S. Units

---

Special Notes :

- | For check valve application, use only with CX\*A check valves - free flow nose to side.

---

Related Information :

- | [Studnuts and Studrods for sandwich bodies - metric units.](#)
- | [Studnuts and Studrods for sandwich bodies - US units](#)



Functional Group:  
Products : Manifolds : Sandwich : Flow Control : ISO 05 : Meter out T

Model:  
DBT

Face : 2

---

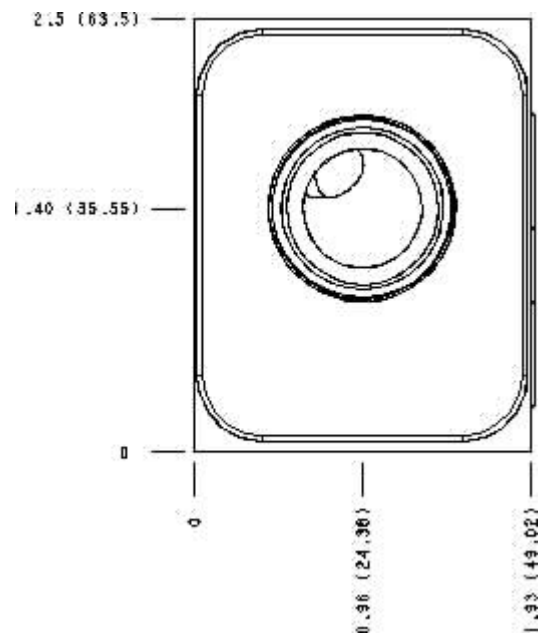

Cartridge extension measurement is to the centerline of the cartridge.

---



Functional Group:  
Products : Manifolds : Sandwich : Flow Control : ISO 05 : Meter out T

Model:  
DBT

Face : 5

---

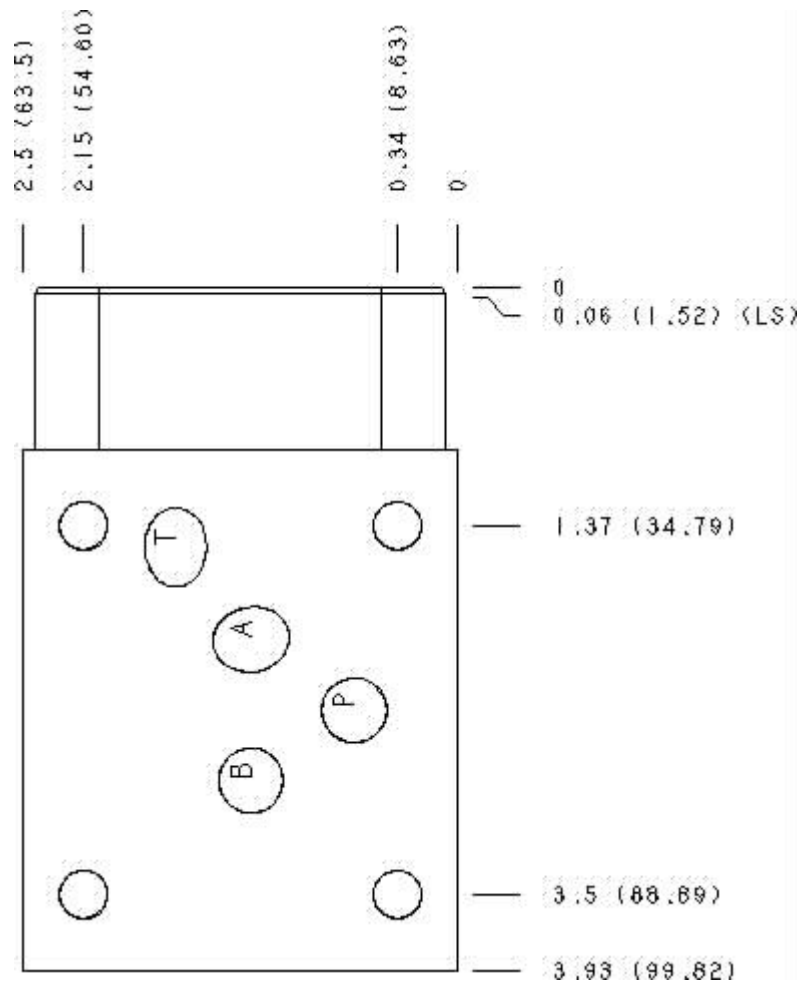

Cartridge extension measurement is to the centerline of the cartridge.



Functional Group:  
 Products : Manifolds : Sandwich : Flow Control : ISO 05 : Meter out T

Model:  
 DBT

Face : 7

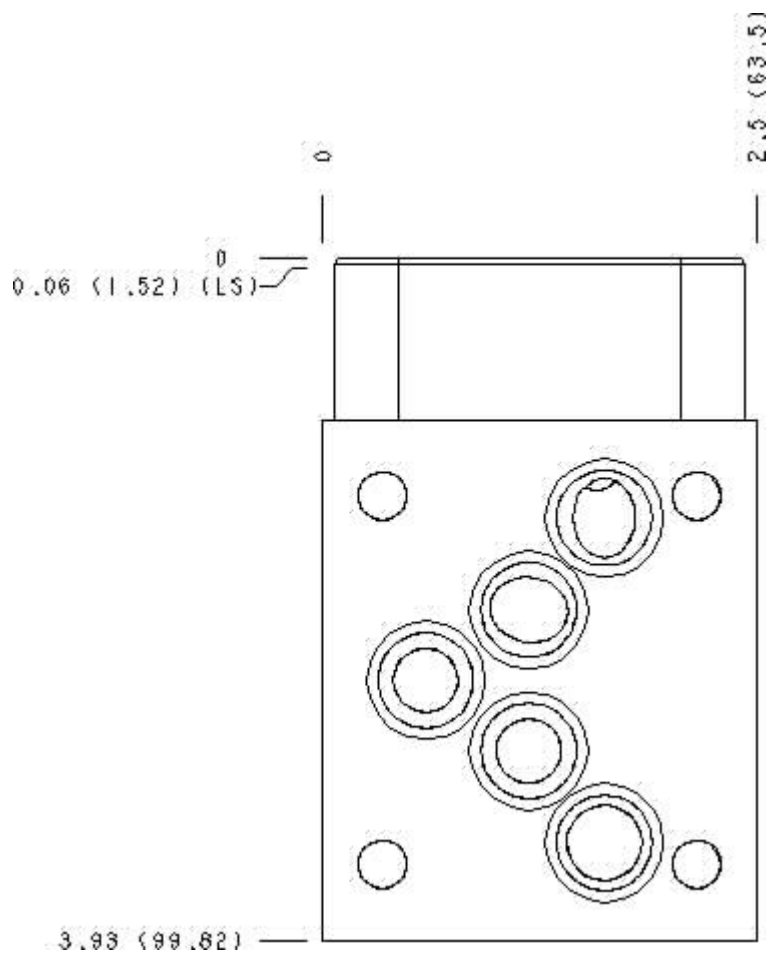

Cartridge extension measurement is to the centerline of the cartridge.



Functional Group:  
 Products : Manifolds : Sandwich : Flow Control : ISO 05 : Meter out T

Model:  
 DBT

Face : 8

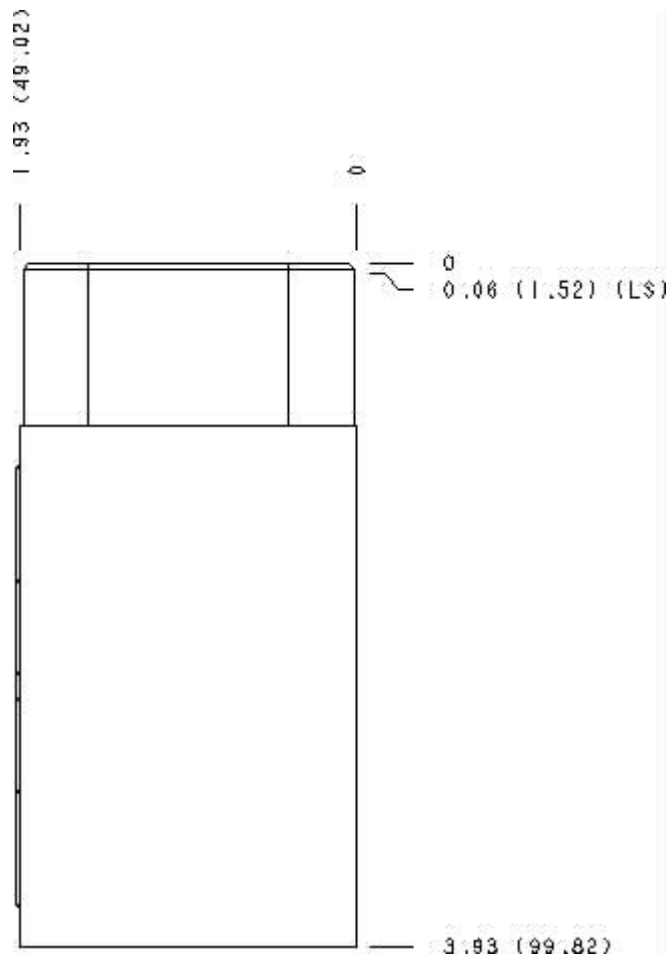

Cartridge extension measurement is to the centerline of the cartridge.



Functional Group:  
 Products : Manifolds : Sandwich : Flow Control : ISO 05 : Meter out T

Model:  
 DBT

Face : 10

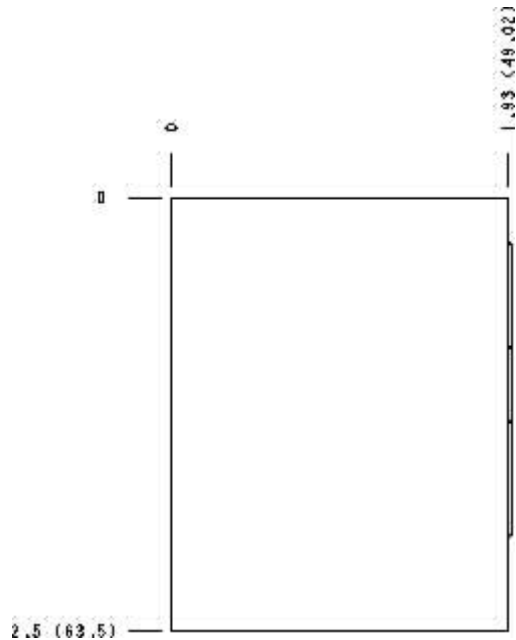

Cartridge extension measurement is to the centerline of the cartridge.



Functional Group:

Products : Manifolds : Sandwich : Flow Control : ISO  
05 : Meter out T

Model:  
DBT

Projection Type

All Dimensions in Inches(mm)

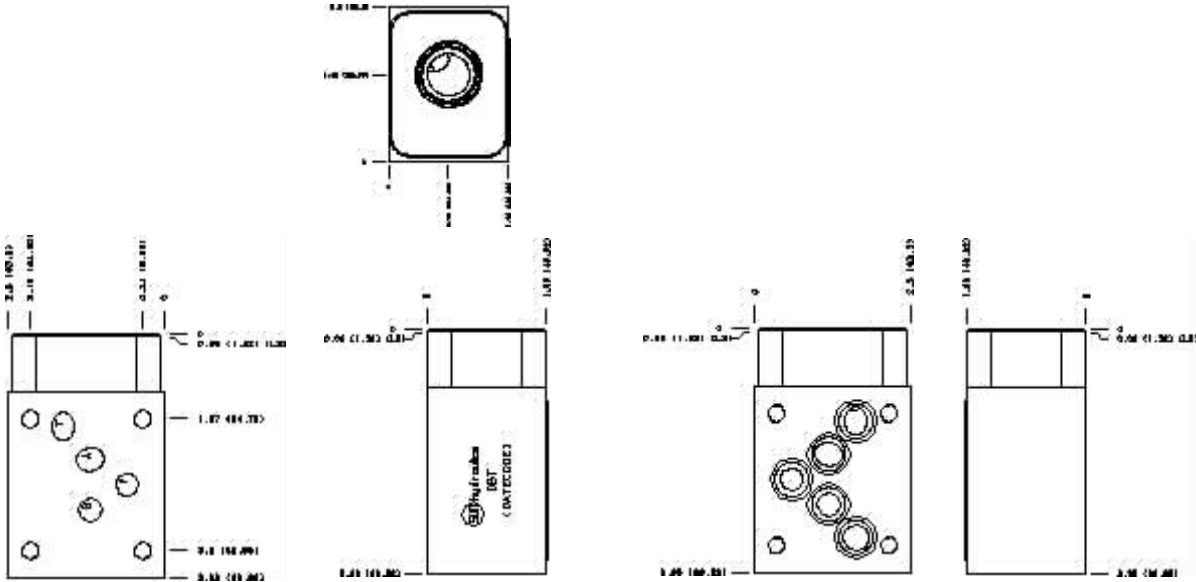

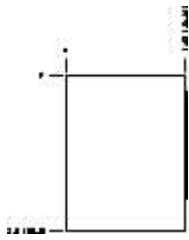

---

Copyright © 2007-2008 Sun Hydraulics Corporation.  
All rights reserved.

[Terms and Conditions](#) - [Statement of Privacy](#)