

Functional Group:

Model:

Products : Manifolds : Subplate : Relief : ISO 08 : P to T, side ports

CSM

Face : 10

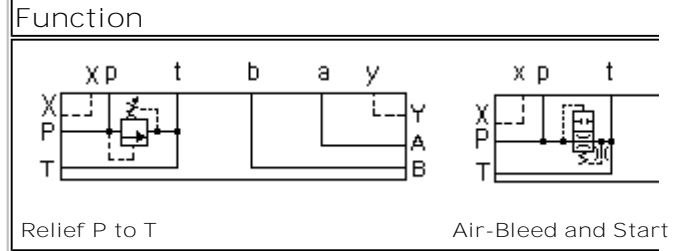
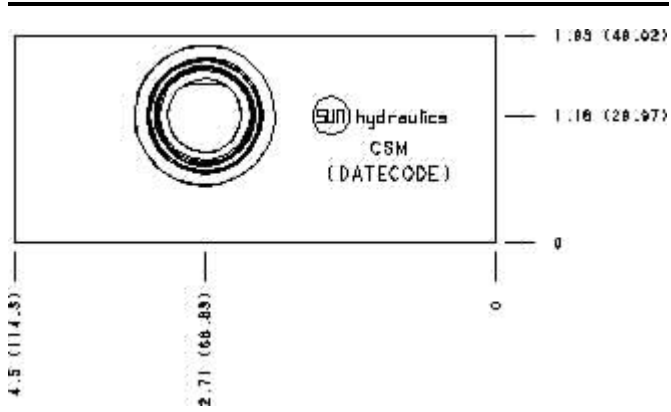

Cartridge extension measurement is to the centerline of the cartridge.

Aluminum Body Pressure Rating: **3000 psi (210 bar)**

Ductile Iron Body Pressure Rating: **5000 psi (350 bar)**

Port Headings and Sizes:

Ports A, B, P, T
SAE 16

Ports X & Y
SAE 6

Gage Port
1/4" NPTF

Technical Data

	U.S. Units	Metric Units
Model Weight	3.65 lb.	1.66 kg.
Cavity	T-3A	
Body Features	P to T, side ports	
Body Type	Subplate	
Interface	ISO 08	
Open Cavity Quantity	1	

Option Selection:

Model Code	Description
CSM	Aluminum, Buna-N, U.S. Units
	Ductile Iron, Buna-N,



Functional Group:
Products : Manifolds : Subplate : Relief : ISO 08 : P to T, side ports

Model:
CSM

Face : 2

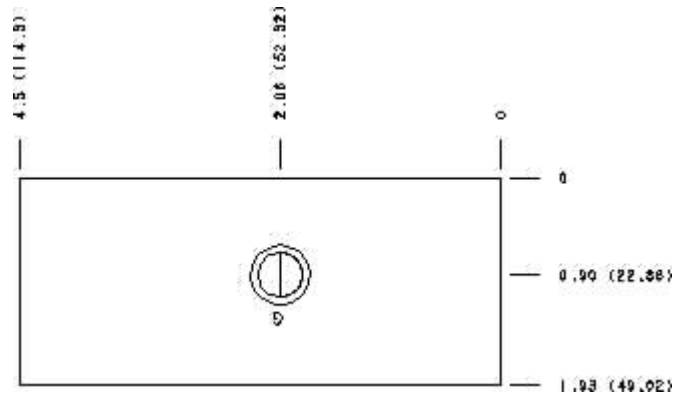

Cartridge extension measurement is to the centerline of the cartridge.



Functional Group:
Products : Manifolds : Subplate : Relief : ISO 08 : P to T, side ports

Model:
CSM

Face : 5

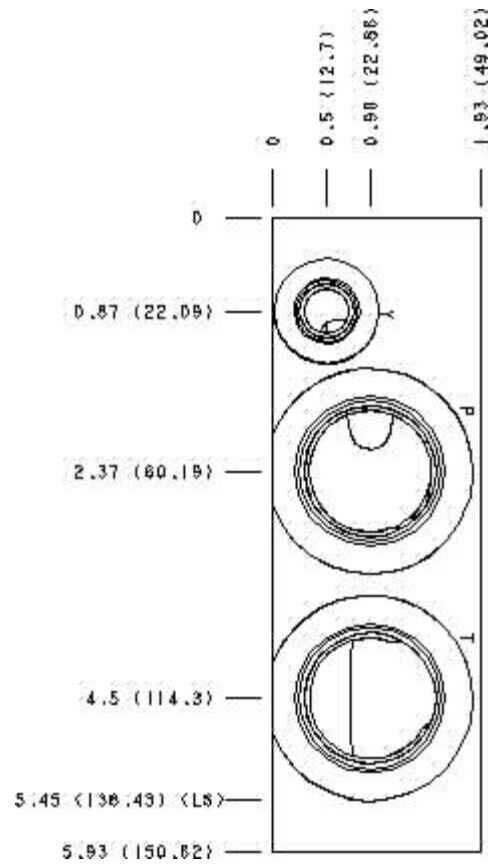

Cartridge extension measurement is to the centerline of the cartridge.



Functional Group:
 Products : Manifolds : Subplate : Relief : ISO 08 : P to T, side ports

Model:
 CSM

Face : 6

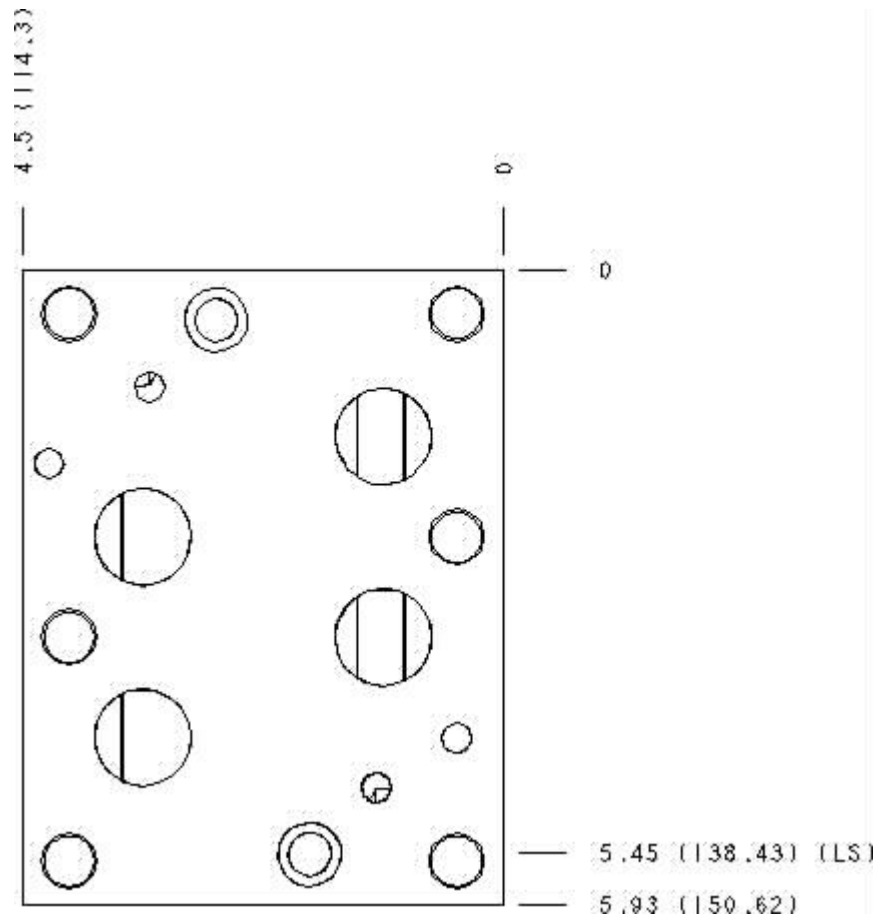

Cartridge extension measurement is to the centerline of the cartridge.



Functional Group:
 Products : Manifolds : Subplate : Relief : ISO 08 : P to T, side ports

Model:
 CSM

Face : 7

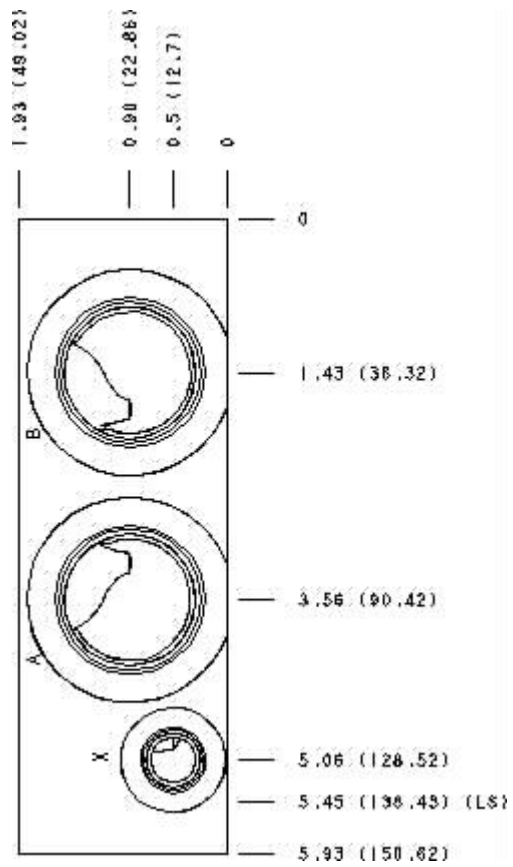

Cartridge extension measurement is to the centerline of the cartridge.



Functional Group:
 Products : Manifolds : Subplate : Relief : ISO 08 : P to T, side ports

Model:
 CSM

Face : 8

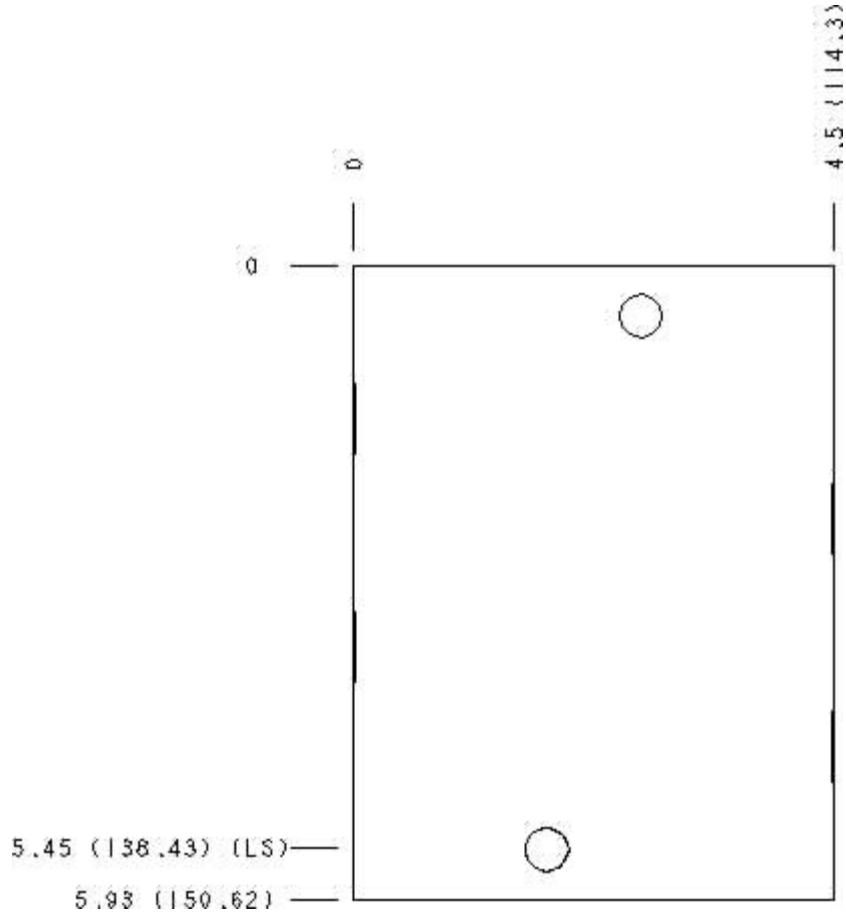

Cartridge extension measurement is to the centerline of the cartridge.



Functional Group:

Products : Manifolds : Subplate : Relief : ISO 08 : P to T, side ports

Model:
CSM

Projection Type 

All Dimensions in Inches(mm)

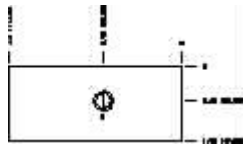

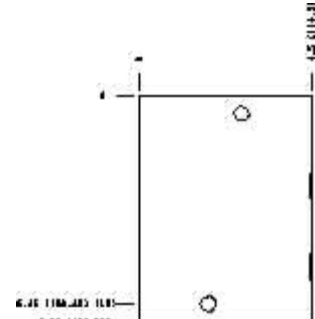
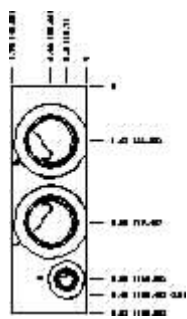
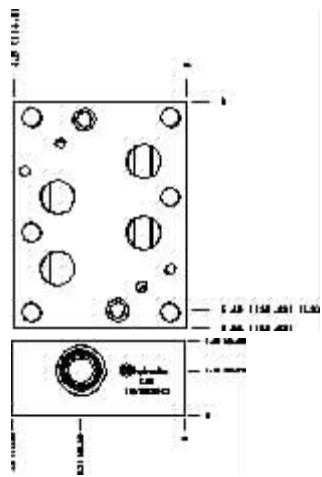
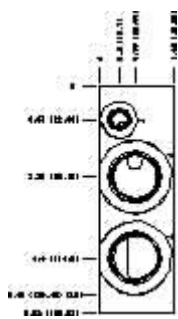

Copyright © 2007-2008 Sun Hydraulics Corporation.
All rights reserved.

[Terms and Conditions](#) - [Statement of Privacy](#)