

Functional Group:

Products : Manifolds : Sandwich : Relief : ISO 07 : A to T

Model:

CKA

Face : 6

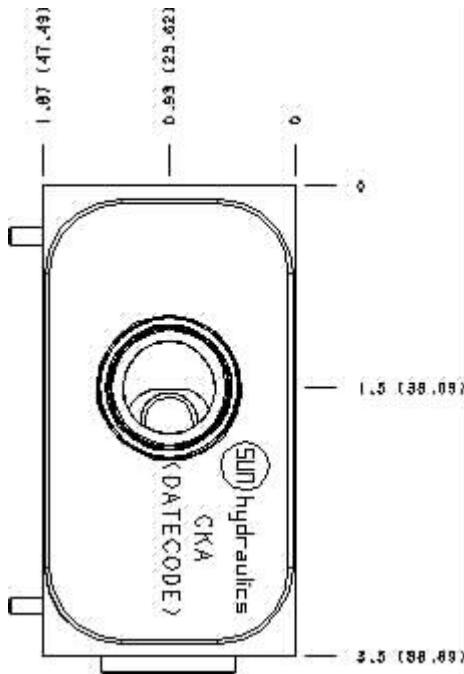

Cartridge extension measurement is to the centerline of the cartridge.

Function

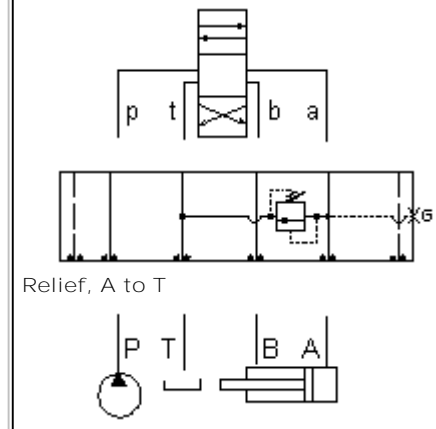

Aluminum Body Pressure Rating: **3000 psi (210 bar)**
 Ductile Iron Body Pressure Rating: **5000 psi (350 bar)**

Port Headings and Sizes:

Gage Port (Plugged)
 1/4" BSPP

Gage Port (Plugged)
 1/4" NPTF

Technical Data

	U.S. Units	Metric Units
Model Weight	2.99 lb.	1.36 kg.
Cavity	T-3A	
Body Features	A to T	
Body Type	Sandwich	
Interface	ISO 07	
Open Cavity Quantity	1	
Stack Height	1.97 in.	50 mm

Option Selection:

Model Code	Description
CKA	Aluminum, Buna-N, U.S. Units
CKA/M	Aluminum, Buna-N, Metric
CKA/S	Ductile Iron, Buna-N, U.S. Units
CKA/T	Ductile Iron, Buna-N, Metric
CKA/V	Aluminum, Viton, U.S. Units
CKA/W	Ductile Iron, Viton, Metric
CKA/Y	Ductile Iron, Viton, U.S. Units
CKA/Z	Aluminum, Viton, Metric

Special Notes :

No Special Notes available for selected Model.



Functional Group:
Products : Manifolds : Sandwich : Relief : ISO 07 : A to T

Model:
CKA

Face : 5

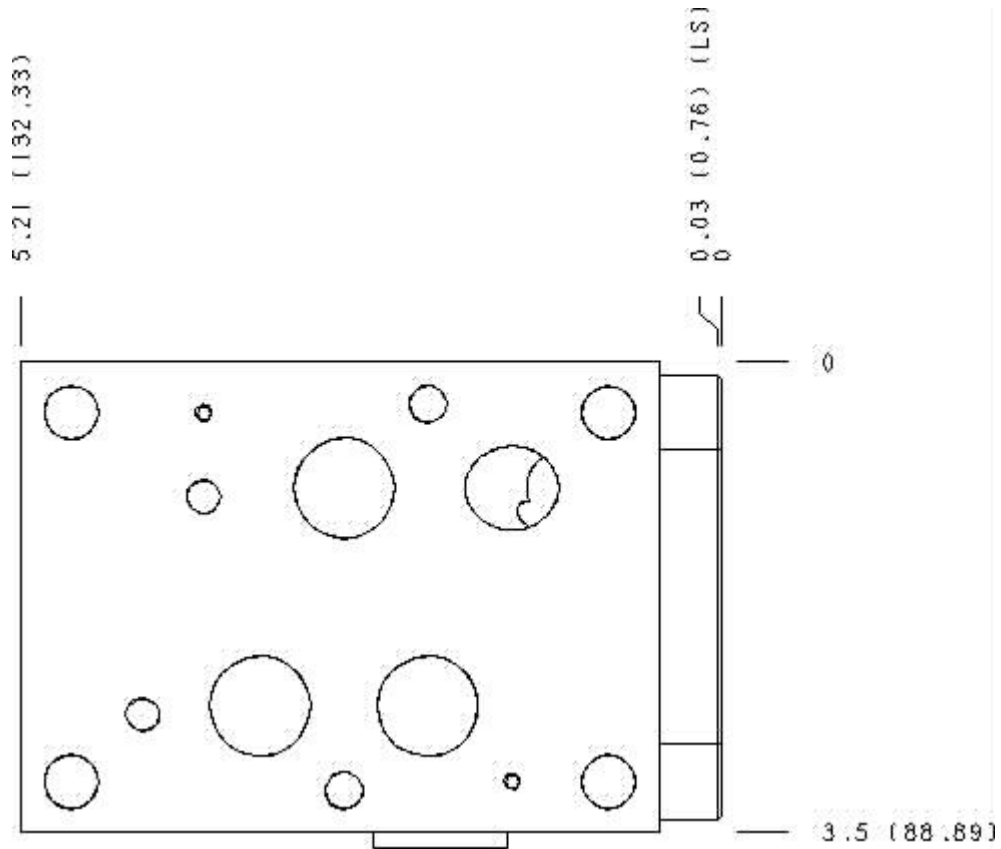

Cartridge extension measurement is to the centerline of the cartridge.



Functional Group:
 Products : Manifolds : Sandwich : Relief : ISO 07 : A to T

Model:
 CKA

Face : 7

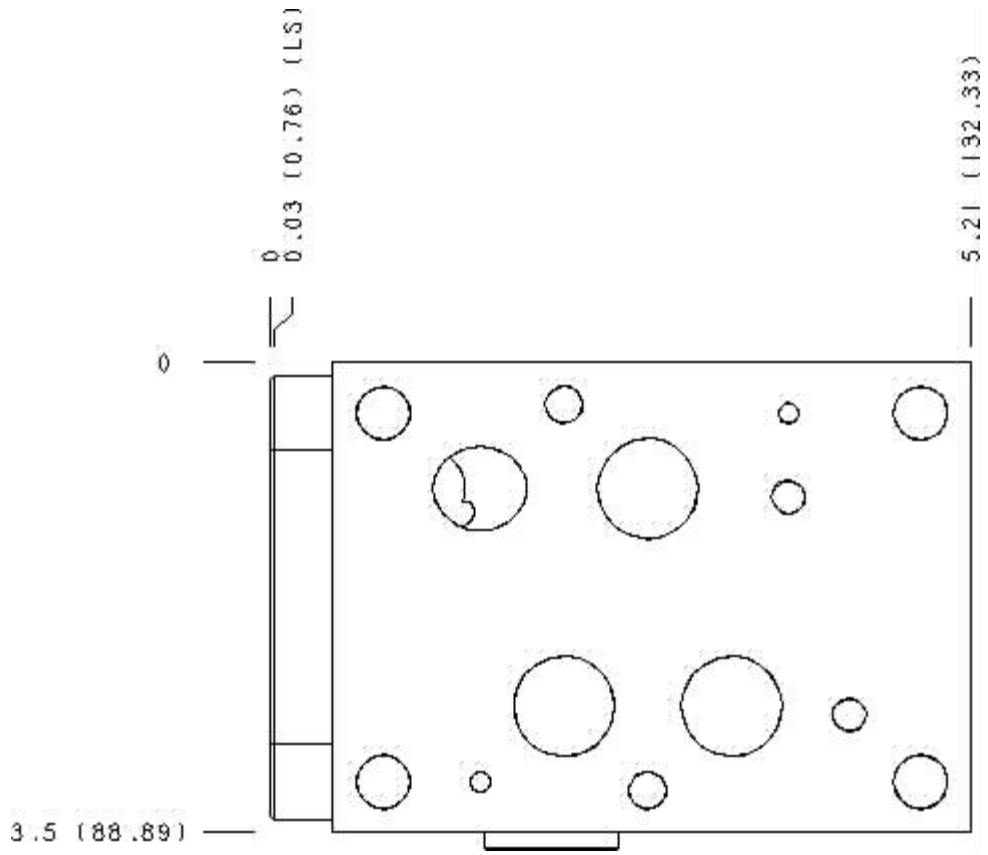

Cartridge extension measurement is to the centerline of the cartridge.



Functional Group:
 Products : Manifolds : Sandwich : Relief : ISO 07 : A to T

Model:
 CKA

Face : 8

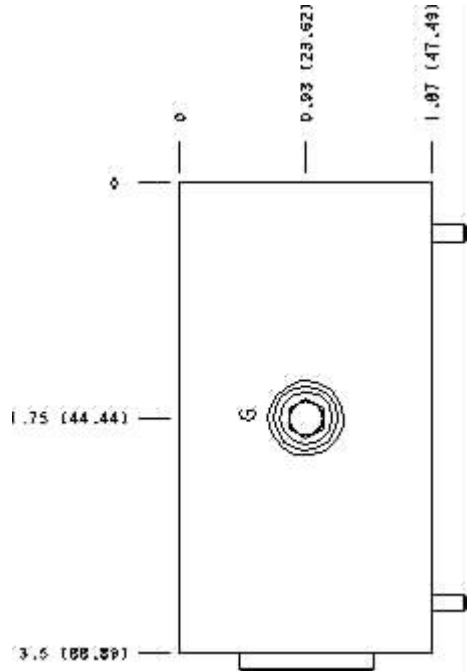

Cartridge extension measurement is to the centerline of the cartridge.



Functional Group:
 Products : Manifolds : Sandwich : Relief : ISO 07 : A to T

Model:
 CKA

Face : 11

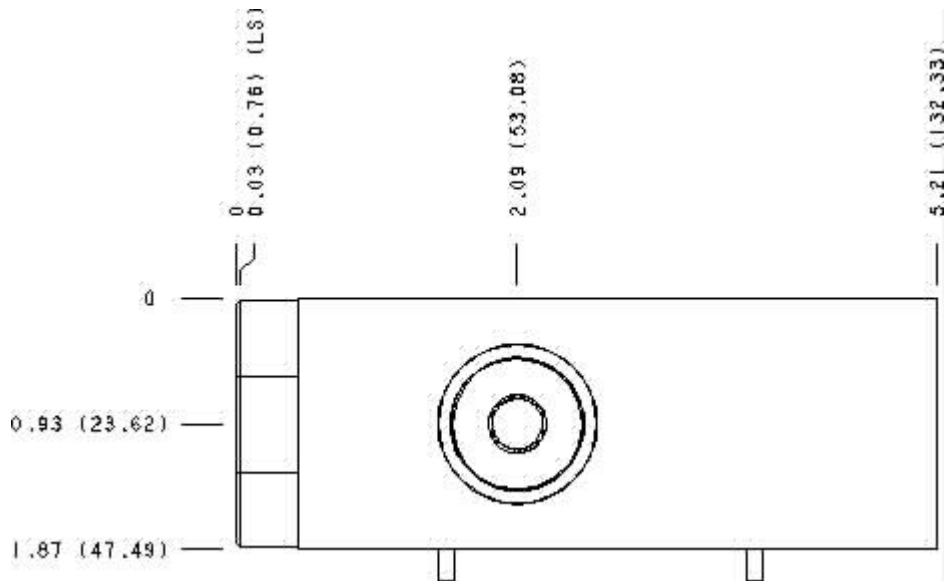

Cartridge extension measurement is to the centerline of the cartridge.



Functional Group:

Products : Manifolds : Sandwich : Relief : ISO 07 : A to T

Model:
CKA

Projection Type 

All Dimensions in Inches(mm)

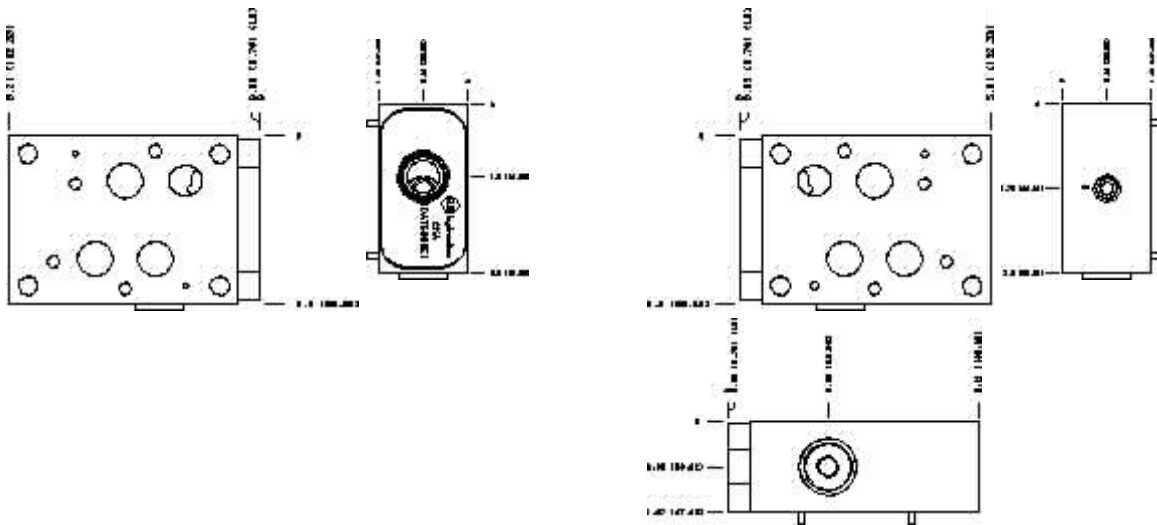

Copyright © 2007-2008 Sun Hydraulics Corporation.
All rights reserved.

[Terms and Conditions](#) - [Statement of Privacy](#)