

3:1 pilot ratio, standard capacity counterbalance valve

Capacity:
120 gpm (480
L/min.)

Functional Group:

Products : Cartridges : Counterbalance : 3-Port Non-vented : Standard, 3:1
Pilot Ratio

Model:
CBI A-LHV

Product Description

Counterbalance valves with pilot assist are meant to control an overrunning load. The check valve allows free flow from the directional valve (port 2) to the load (port 1) while a direct-acting, pilot-assisted relief valve controls flow from port 1 to port 2. Pilot assist at port 3 lowers the effective setting of the relief valve at a rate determined by the pilot ratio.

Other names for this valve include motion control valve and over center valve.

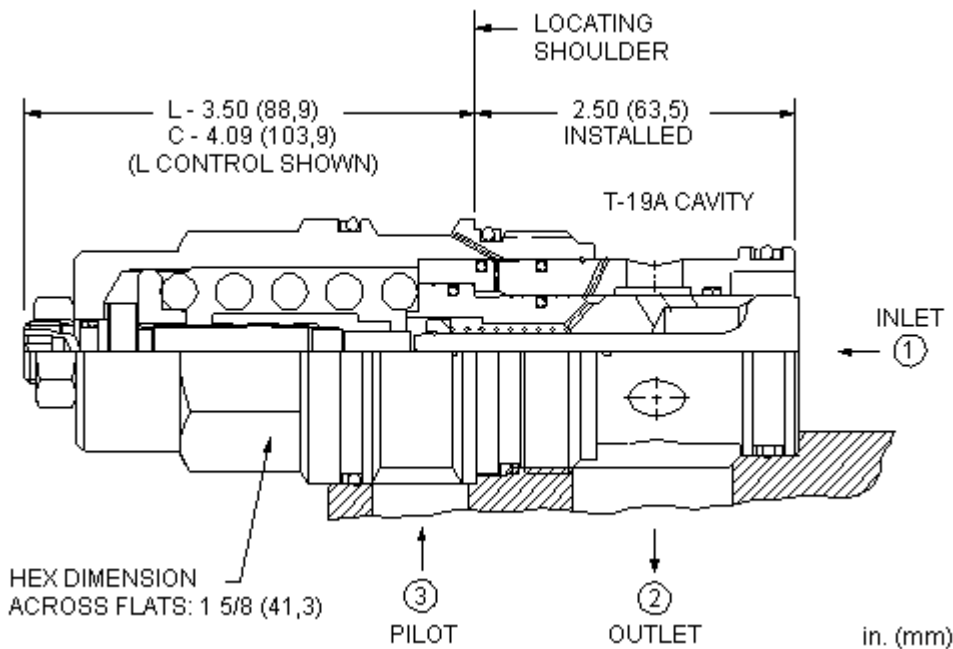
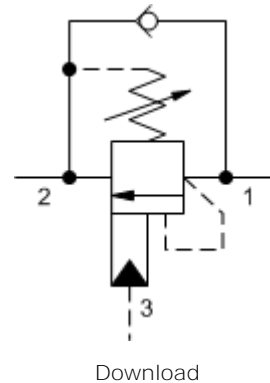

Technical Features

- Counterbalance valves should be set at least 1.3 times the maximum load induced pressure.
- Full clockwise setting is less than 200 psi (14 bar).
- Reseat exceeds 85% of set pressure when the valve is standard set. Settings lower than the standard set pressure may result in lower reseal percentages.
- Turn adjustment clockwise to decrease setting and release load.
- Backpressure at port 2 adds to the effective relief setting at a ratio of 1 plus the pilot ratio times the backpressure.
- Sun counterbalance cartridges can be installed directly into a cavity machined in an actuator housing for added protection and improved stiffness in the circuit.

- Two check valve cracking pressures are available. Use the 25 psi (1,7 bar) check unless actuator cavitation is a concern.
- All 3-port counterbalance, load control, and pilot-to-open check cartridges are physically interchangeable (i.e. same flow path, same cavity for a given frame size).
- This valve has positive seals between all ports.
- Incorporates the Sun floating style construction to minimize the possibility of internal parts binding due to excessive installation torque and/or cavity/cartridge machining variations.

Technical Data

	U.S. Units	Metric Units
Model Weight	3.00 lb.	1.36 kg.
Cavity	T-19A	
Capacity	120 gpm	480 L/min.
Pilot Ratio	3: 1	
Maximum Recommended Load Pressure at Maximum Setting	3075 psi	215 bar
Maximum Setting	4000 psi	280 bar
Adjustment - Number of Counterclockwise Turns to Increase Setting	3.75	
Factory Pressure Settings Established at	2 in ³ /min.	30 cc/min.
Maximum Valve Leakage at Reseat	5 drops/min.	0,4 cc/min.
Series (from Cavity)	Series 4	
Reseat	>85% of Set Pressure	
Valve Hex Size	1 5/8 in.	41,3 mm
Valve Installation Torque	350 - 375 lbf ft	465 - 500 Nm
Adjustment Screw Hex Socket Size	7/32 in.	5,5 mm
Adjustment Nut Hex Size	3/4 in.	19,1 mm
Adjustment Nut Torque	25 lbf ft	35 Nm
Seal Kits	Buna: 990-019-007	
Seal Kits	Viton: 990-019-006	

Free Flow and Piloted Open Pressure Drop

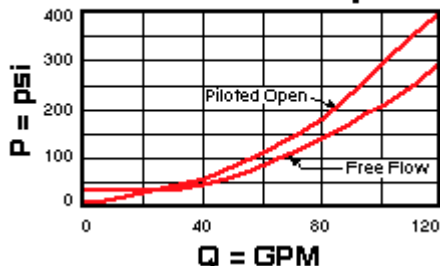

Typical Relief Characteristics

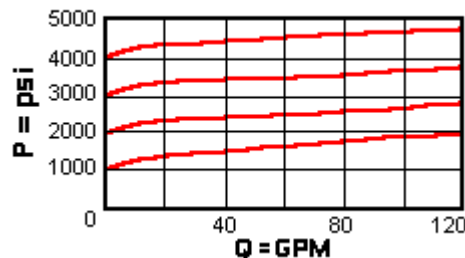

Free Flow and Piloted Open Pressure Drop

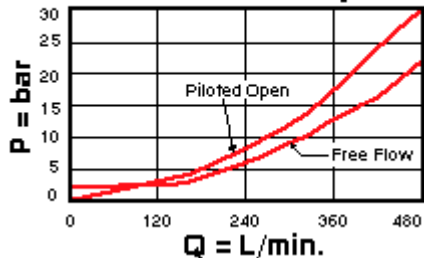

Typical Relief Characteristics

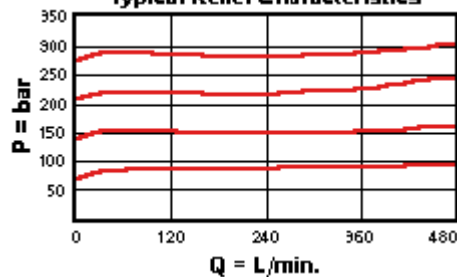

Control

Functional Setting Range

External Material/Seal
Material

L Standard Screw Adjustment	+0.00	H 1000 - 4000 psi w/25 psi Check (70 - 280 bar w/1,7 bar Check), 3000 psi (210 bar) Standard Setting	+0.00	V Viton +5.00
-----------------------------	-------	--	-------	---------------

Customer specified setting stamped on hex \$1.10

- Explanation of Sun cartridge control options - US units.
- Explanation of Sun cartridge control options - metric units.

Copyright © 2007-2008 Sun Hydraulics Corporation. All rights reserved.
Terms and Conditions - ISO Certification - Statement of Privacy