

Functional Group:

Products : Manifolds : Sandwich : Relief : ISO 05 : P to T

Model:

CBE

Face : 7

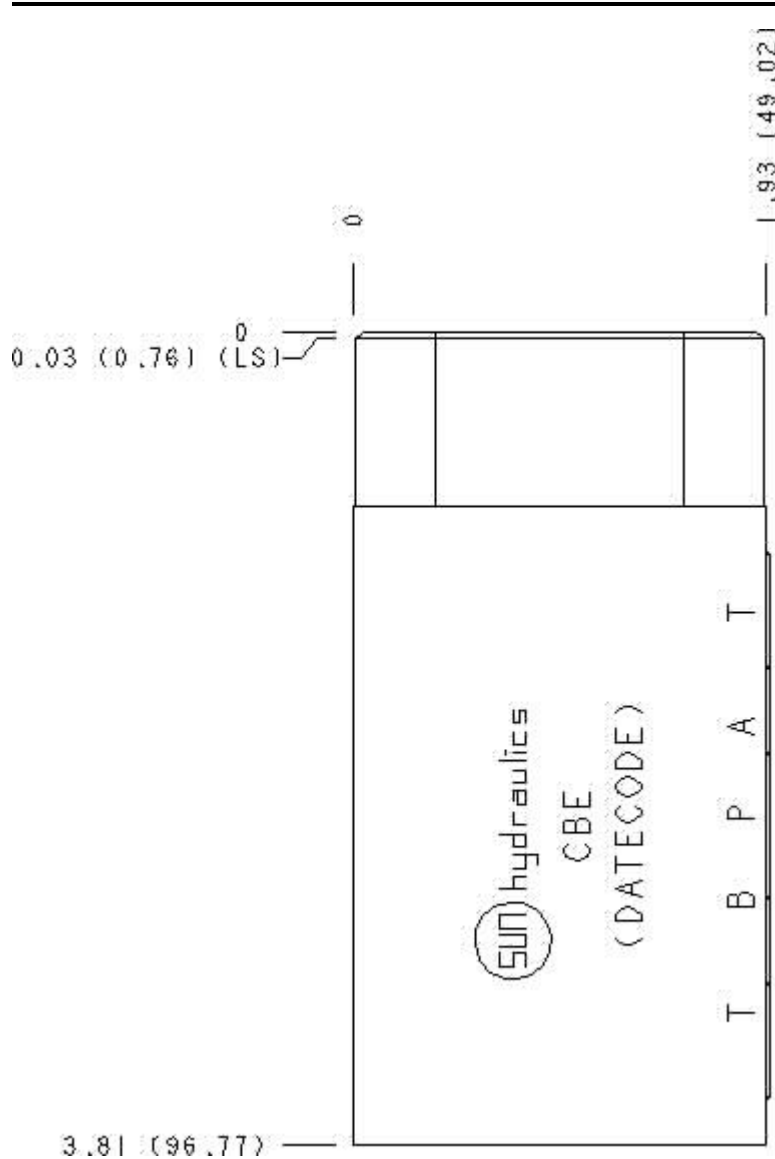

Cartridge extension measurement is to the centerline of the cartridge.

Function

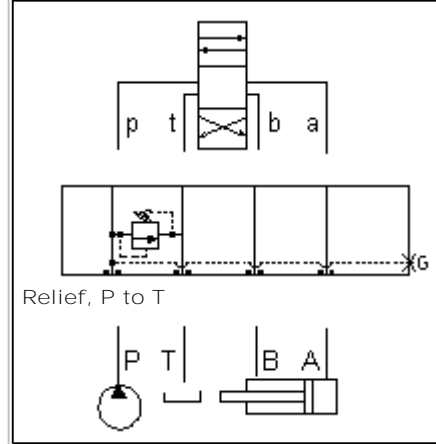

Aluminum Body Pressure Rating: **3000 psi (210 bar)**
 Ductile Iron Body Pressure Rating: **5000 psi (350 bar)**

Port Headings and Sizes:

Gage Port (Plugged)
 1/4" BSPP

Gage Port (Plugged)
 1/4" NPTF

Technical Data

	U.S. Units	Metric Units
Model Weight	1.50 lb.	0.68 kg.
Cavity	T-10A	
Body Features	P to T	
Body Type	Sandwich	
Interface	ISO 05	
Open Cavity Quantity	1	
Stack Height	1.94 in.	49 mm

Option Selection:

Model Code	Description
CBE	Aluminum, Buna-N, U.S. Units
CBE/M	Aluminum, Buna-N, Metric
CBE/S	Ductile Iron, Buna-N, U.S. Units
CBE/T	Ductile Iron, Buna-N, Metric
CBE/V	Aluminum, Viton, U.S. Units
CBE/W	Ductile Iron, Viton, Metric
CBE/Y	Ductile Iron, Viton, U.S. Units
CBE/Z	Aluminum, Viton, Metric

Special Notes :

No Special Notes available for selected Model.



Functional Group:
 Products : Manifolds : Sandwich : Relief : ISO 05 : P to T

Model:
 CBE

Face : 2

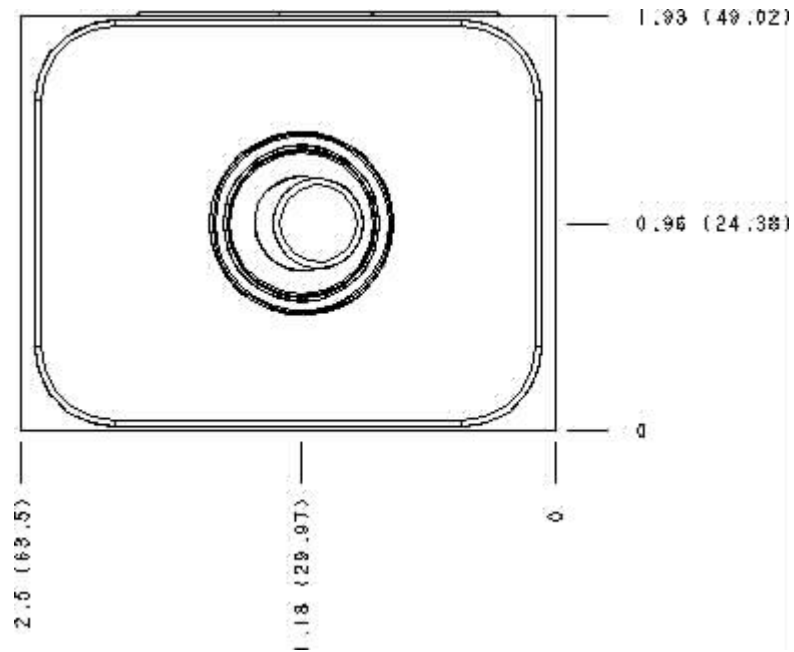

Cartridge extension measurement is to the centerline of the cartridge.



Functional Group:
 Products : Manifolds : Sandwich : Relief : ISO 05 : P to T

Model:
 CBE

Face : 6

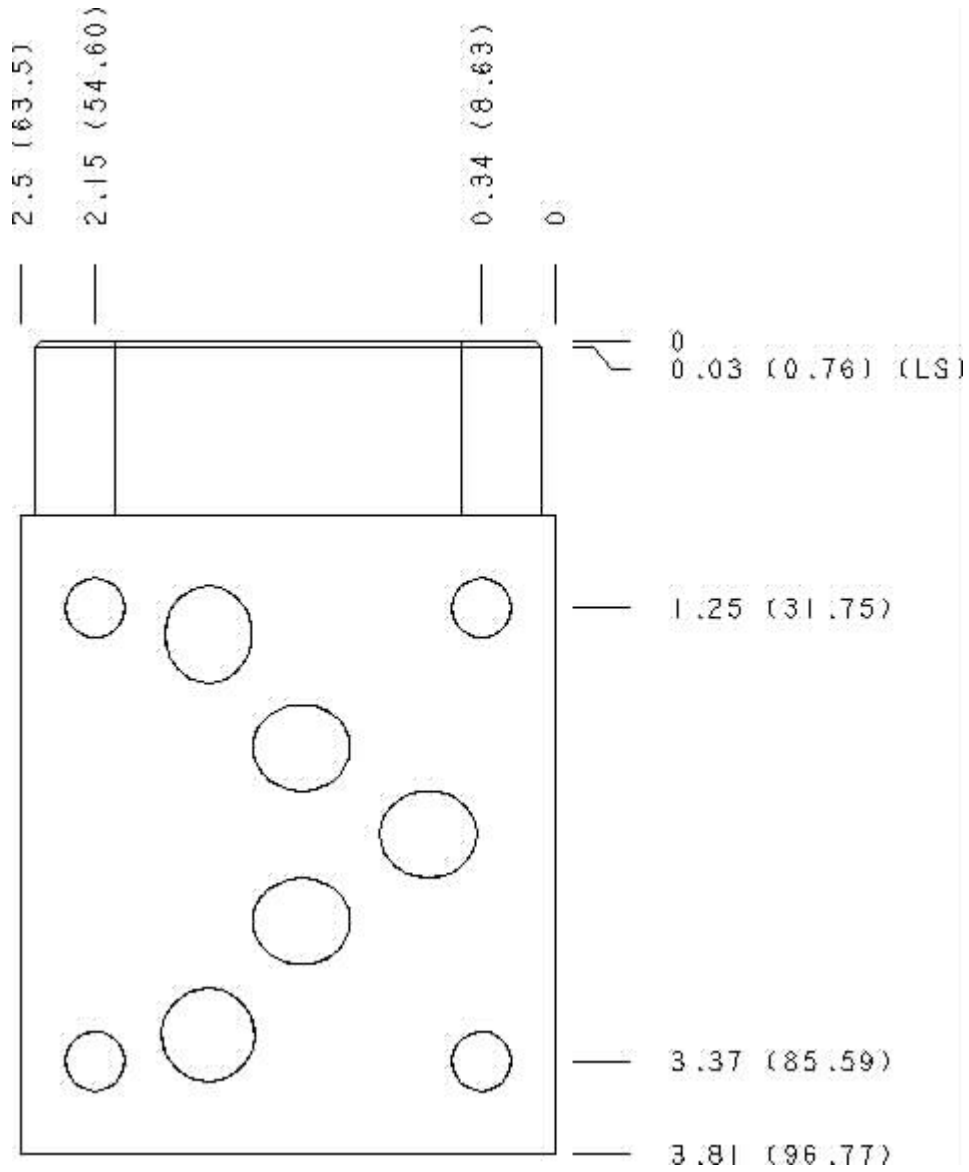

Cartridge extension measurement is to the centerline of the cartridge.



Functional Group:
 Products : Manifolds : Sandwich : Relief : ISO 05 : P to T

Model:
 CBE

Face : 8

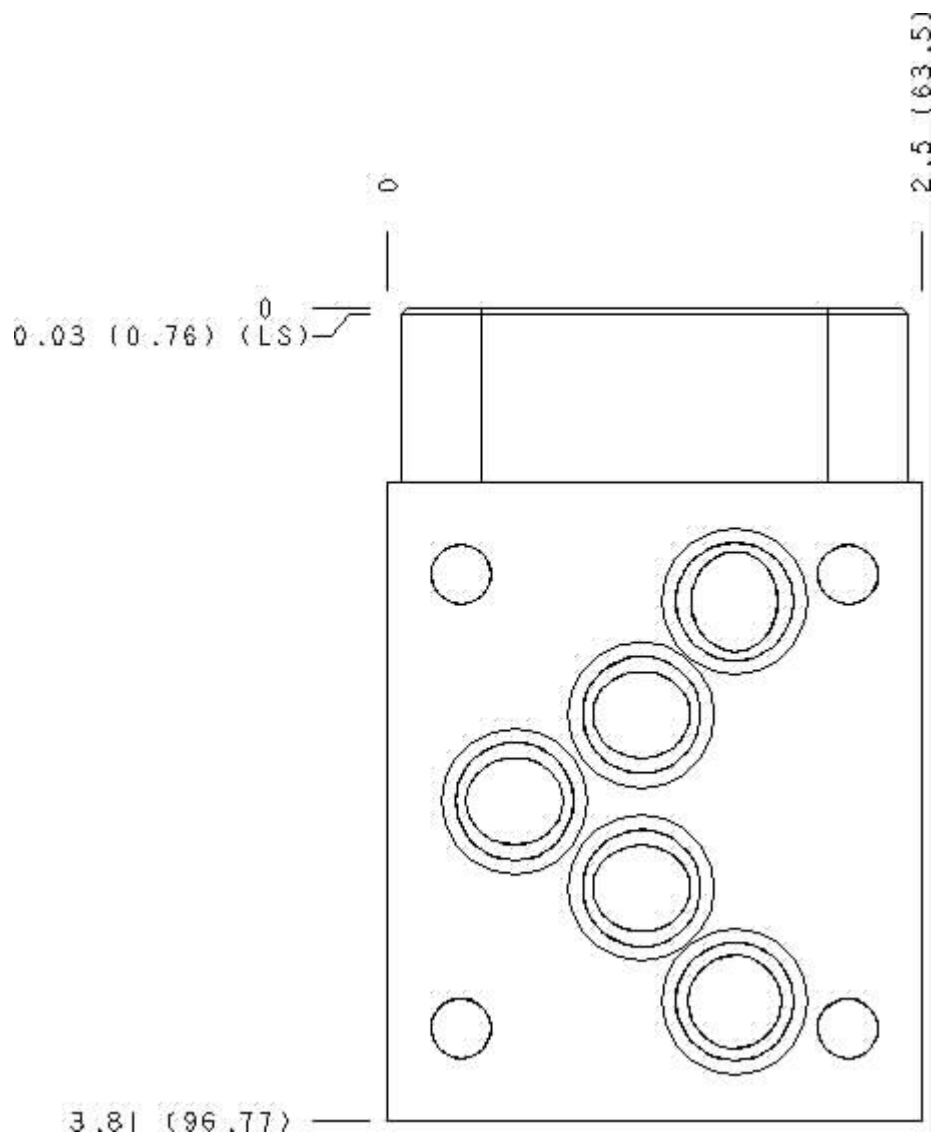

Cartridge extension measurement is to the centerline of the cartridge.



Functional Group:
 Products : Manifolds : Sandwich : Relief : ISO 05 : P to T

Model:
 CBE

Face : 10

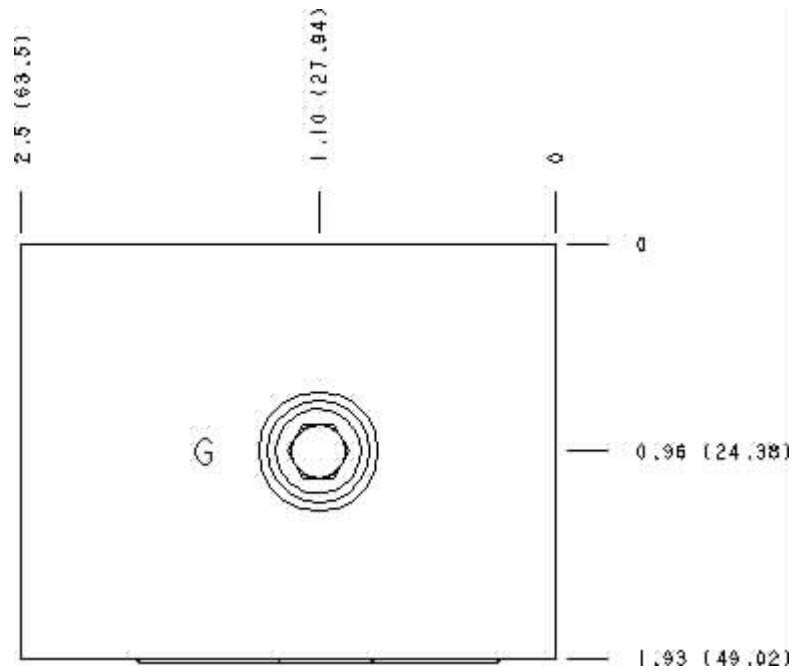

Cartridge extension measurement is to the centerline of the cartridge.



Functional Group:

Products : Manifolds : Sandwich : Relief : ISO 05 : P to T

Model:
CBE

Projection Type

All Dimensions in Inches(mm)

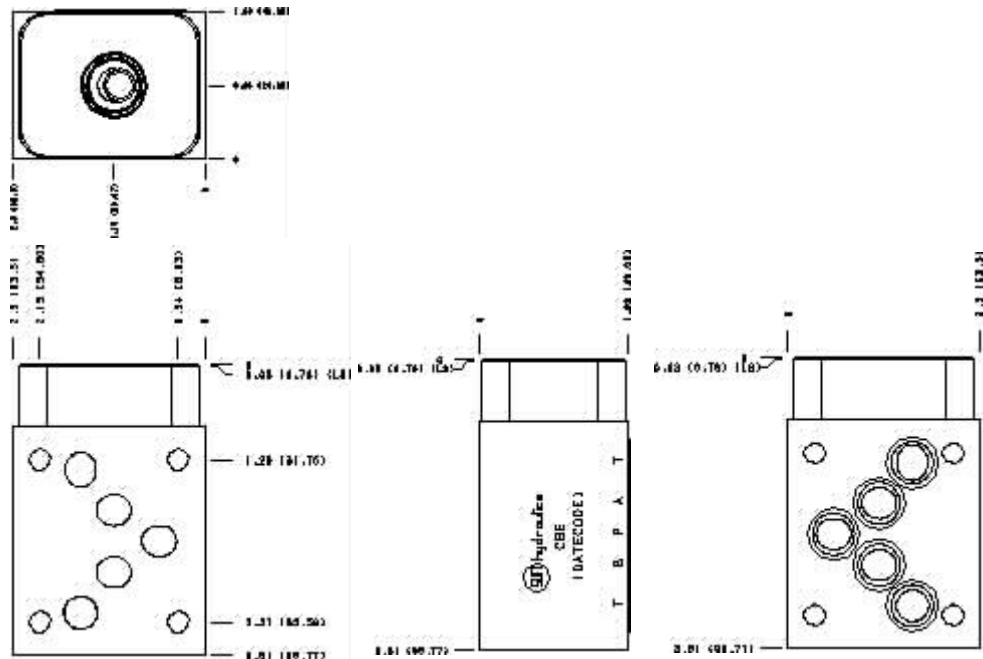

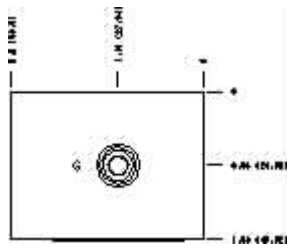

Copyright © 2007-2008 Sun Hydraulics Corporation.
All rights reserved.

[Terms and Conditions](#) - [Statement of Privacy](#)