

3:1 pilot ratio, vented counterbalance valve - atmospherically referenced

Functional Group:

Products : Cartridges : Counterbalance : 3-Port Atmospherically Referenced : Atmospherically Referenced, 3:1 Pilot Ratio

Capacity:
15 gpm (60 L/min.)

Model:
CACA-LHN

Product Description

Atmospherically-vented counterbalance valves with pilot assist are meant to control an overrunning load. The check valve allows free flow from the directional valve (port 2) to the load (port 1) while a direct-acting, pilot-assisted relief valve controls flow from port 1 to port 2. Pilot assist at port 3 lowers the effective setting of the relief valve at a rate determined by the pilot ratio. Backpressure at port 2 does not affect the valve setting because the spring chamber is atmospherically referenced.

Other names for this valve include motion control valve and over center valve.

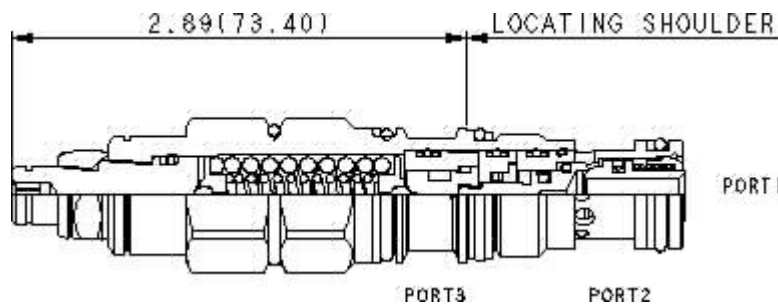
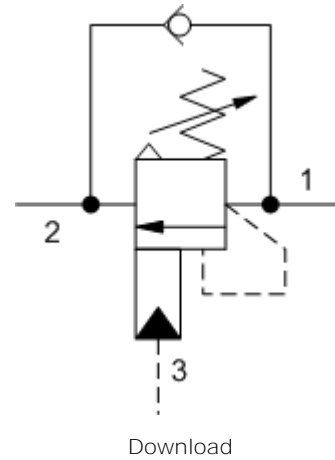

Technical Features

- Counterbalance valves should be set at least 1.3 times the maximum load induced pressure.
- Full clockwise setting is 0 psi (0 bar).
- Reseat exceeds 85% of set pressure when the valve is standard set. Settings lower than the standard set pressure may result in lower reseal percentages.
- This valve has positive seals between all ports.
- Three-port vented valves are atmospherically referenced and considered problem solvers for existing circuits using non-vented valves. Over time, the vented valves may leak externally or allow moisture into the spring chamber. Four-port vented counterbalance valves are recommended for new applications.
- Turn adjustment clockwise to decrease setting and release load.
- Approximately 1 drop of fluid will pass from the pilot area to the vented spring chamber every 4000 cycles.
- Sun counterbalance cartridges can be installed directly into a cavity machined in an actuator housing for added protection and improved stiffness in the circuit.
- With vented valves, a lower pilot ratio may be required to achieve machine stability compared to non-vented valves.
- All 3-port counterbalance, load control, and pilot-to-open check cartridges are physically interchangeable (i.e. same flow path, same cavity for a given frame size).

- Incorporates the Sun floating style construction to minimize the possibility of internal parts binding due to excessive installation torque and/or cavity/cartridge machining variations.

Technical Data

	U.S. Units	Metric Units
Cavity	T-11A	
Capacity	15 gpm	60 L/min.
Pilot Ratio	3:1	
Maximum Recommended Load Pressure at Maximum Setting	3075 psi	215 bar
Maximum Setting	4000 psi	280 bar
Adjustment - Number of Counterclockwise Turns to Increase Setting	5	
Factory Pressure Settings Established at	2 in ³ /min.	30 cc/min.
Maximum Valve Leakage at Reseat	5 drops/min.	0,4 cc/min.
Reverse Flow Check Cracking Pressure	40 psi	2,8 bar
Series (from Cavity)	Series 1	
U.S. Patent #	4,834,135	
Reseat	>85% of Set Pressure	
Valve Hex Size	7/8 in.	22,2 mm
Valve Installation Torque	30 - 35 lbf ft	45 - 50 Nm
Adjustment Screw Hex Socket Size	5/32 in.	4 mm
Adjustment Nut Hex Size	9/16 in.	15 mm
Adjustment Nut Torque	108 lbf in.	12 Nm
Model Weight	.40 lb	0,20 kg
Seal Kits	Buna: 990-211-007	
Seal Kits	Viton: 990-211-006	

Free Flow and Piloted Open Pressure Drop

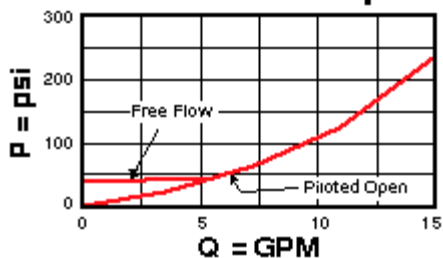

Free Flow and Piloted Open Pressure Drop

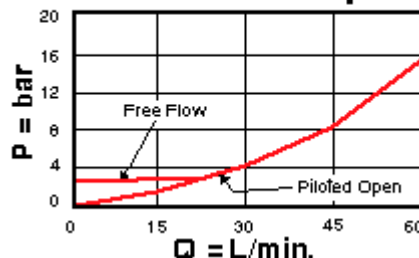

CACA-LHN

Control

Functional Setting Range

External Material/Seal Material

L Standard Screw Adjustment

+0.00

H 1000 - 4000 psi (70 - 280 bar), 3000 psi (210 bar) Standard Setting

+0.00

N Buna-N +0.00

Customer specified setting stamped on hex \$1.10

- Explanation of Sun cartridge control options - US units.
- Explanation of Sun cartridge control options - metric units.

Copyright © 2007-2008 Sun Hydraulics Corporation. All rights reserved.
Terms and Conditions - ISO Certification - Statement of Privacy