

Counterbalance, On A and B, Cross-Piloted

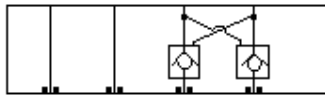

Pilot Operated Check, On A and B, Cross-Piloted

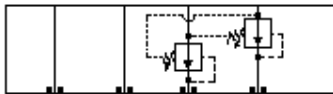

Reducing, On A and B drain to opposite port

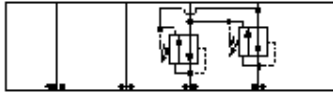

Reducing/Relieving, On A and B, Tank to Opposite Port

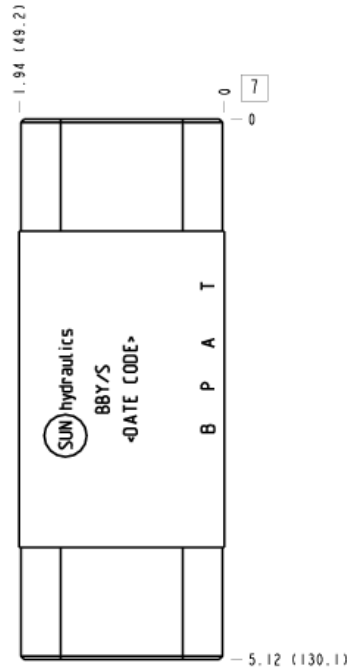
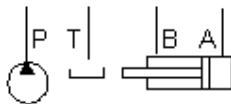

TECHNICAL DATA

Body Type	Sandwich
Interface	ISO 05
Body Features	On A and B with cross pilot
Stack Height	1.94 in.
Open Cavities	2
Cavity	T-2A
Model Weight	4.83 lb.

CONFIGURATION

/S Modifier 65-45-12 Ductile Iron, Buna-N, Chem. Black

NOTES

Important: Carefully consider the maximum system pressure. The pressure rating of the manifold is dependent on the manifold material, with the port type/size a secondary consideration. Manifolds constructed of aluminum are not rated for pressures higher than 3000 psi (210 bar), regardless of the port type/size specified.

INCLUDED COMPONENTS

Part	Description	Quantity
500-001-014	O-Ring	5
850-004-188	Plug	2

CONFIGURATION OPTIONS

Model Code Example: BBY/S

MODIFIER (S)

- /S** 65-45-12 Ductile Iron, Buna-N, Chem. Black
6061-T651 Aluminum, Buna-N
- /11** 6061-T651 Aluminum, Buna-N, Clear Anodize - Per MIL SPEC 8625F Type II, Class I
- /10** 6061-T651 Aluminum, Buna-N, Black Anodize - Per MIL SPEC 8625F Type II, Class II
- /V** 6061-T651 Aluminum, Viton
- /16** 6061-T651 Aluminum, Viton, Clear Anodize - Per MIL SPEC 8625F Type II, Class I
- /15** 6061-T651 Aluminum, Viton, Black Anodize - Per MIL SPEC 8625F Type II, Class II
- /S3** 65-45-12 Ductile Iron, Buna-N, Trivalent Clear Zinc with Top Sealer
- /Y** 65-45-12 Ductile Iron, Viton, Chem. Black
- /Y3** 65-45-12 Ductile Iron, Viton, Trivalent Clear Zinc with Top Sealer

MANIFOLD FACES

FACE GRID

1	2	3	4
5	6	7	8
9	10	11	12

Face 2

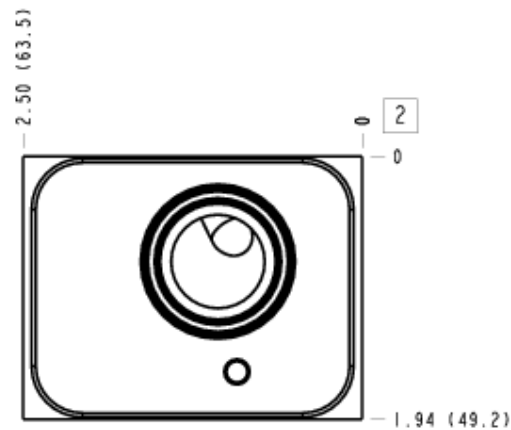

Face 5

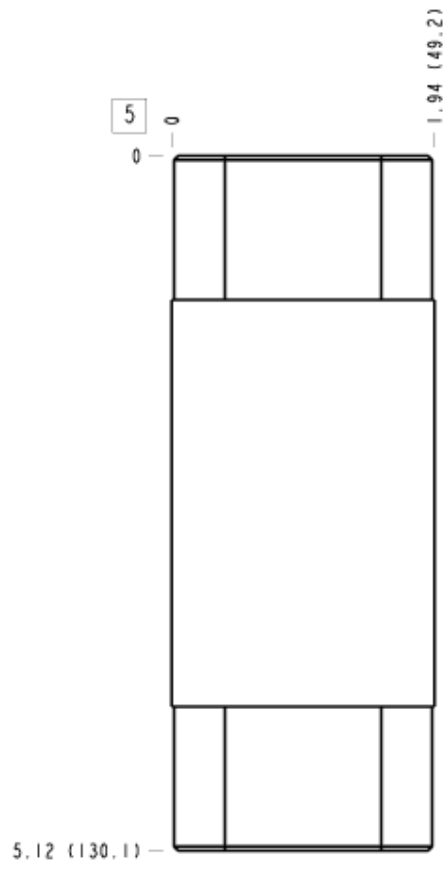

Face 6

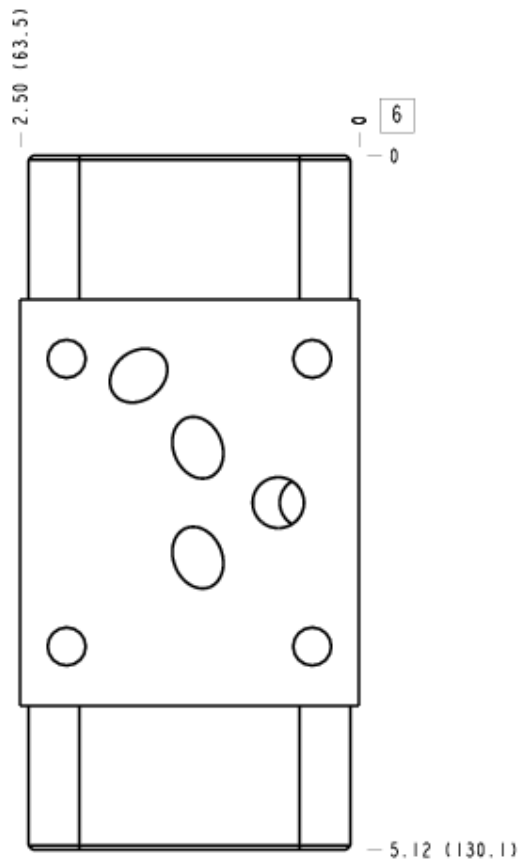

Face 7

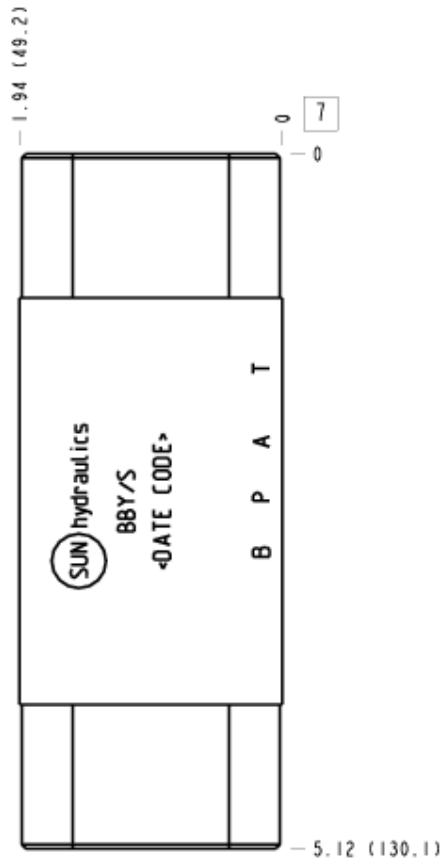

Face 8

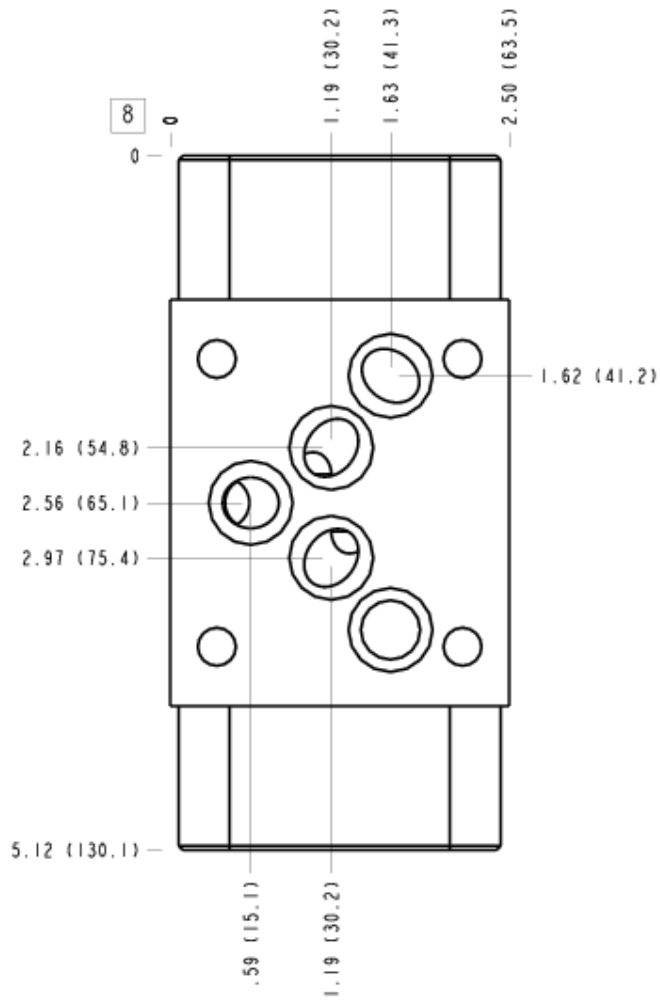

Face 10

