

TIE-ROD MODEL CODE IDENTIFICATION MATRIX

MODEL CODE SYSTEM B 350 160 ABAAA07B

MODELS:

B=B SERIES-3000 PSI
A=ASAE VERSION OF B SERIES
(8" & 16" Strokes only,
8" stroke not available
in 4.5" & 5" bore size.)

BORE SIZE:

200=2.00" Bore 400=4.00" Bore
250=2.50" Bore 450=4.50" Bore
300=3.00" Bore 500=5.00" Bore
350=3.50" Bore

STROKE: (Inches)

First two digits are in inches
Third digit is 0-7 representing
1/8's of an inch for custom strokes.
Consult Prince for over 48"

GLAND PORT LOCATIONS: (See Pictorial Below)

A=(Top Port, STD)
B=(R. Side Port)
C=(Bottom Port)
D=(L. Side Port)

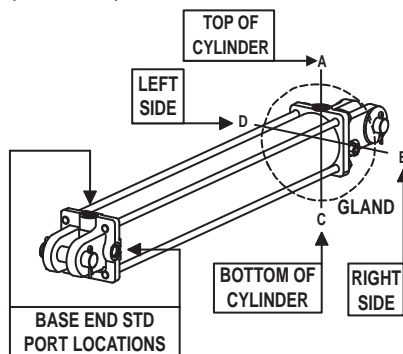

PORT LOCATION DETERMINED FROM VIEWING
CYLINDER FROM BASE END.

(See Table Below) **PORT STYLE & SIZE:**

CODE	PORT TYPE & SIZE	CYLINDER BORE SIZE (Inch)						
		2.00	2.50	3.00	3.50	4.00	4.50	5.00
A	#6 SAE ORB (9/16-18)	O	O	O	O	O	O	O
B	#8 SAE ORB (3/4-16)	S	S	S	S	S	O	O
C	#10 SAE ORB (7/8-14)						S	S
D	NPTF 3/8	O	O	O	O	O	O	O
E	NPTF 1/2	O	O	O	O	O	O	O
F	NPTF 3/4							O

Table Identifiers: (For Tables Above)

S-STANDARD 0-OPTIONAL BLANK-NOT AVAILABLE

CARTON & DECAL CODE

A=No carton-Std decals, Installed
B=Carton-Std decals, Installed (STD)
C=No carton-Std decals, Loose
D=Carton-Std decals, Loose
E=No carton-Std decals, customer I.D. decal, Installed
F=Carton-Std decals, customer I.D. decal, Installed
G=No carton-Std decals, customer I.D. decal, Loose
H=Carton-Std decals, customer I.D. decal, Loose
J=No carton-Customer I.D. decal, Installed
K=Carton-Customer I.D. decal, Installed
L=No carton-Customer I.D. decal, Loose
M=Carton-Customer I.D. decal, Loose
N=No carton-Warning decals, Installed
P=Carton-Warning decals, Installed
Q=No carton-Warning decal, Loose
R=Carton-Warning decals, Loose
S=No carton-Warning, Customer I.D. decal, Installed
T=Carton-Warning, Customer I.D. decal Installed
U=No carton-Warning, Customer I.D. decal, Loose
V=Carton-Warning, Customer I.D. decal, Loose

PAINT:

00=No Paint	14=Gloss White
01=Gloss Red	20=Red Primer
03=Highway Yellow	30=Black Primer
04=Canary Yellow	35=Naval Gray
05=Green	50=Yellow Primer
06=Blue	53=Gray Primer
07=Gloss Black (STD)	55=Silver Gray
	58=Gray

CLEVIS PIN INSTALLATION & RETAINER OPTIONS:

A=Cotter Pins & Clevis Pin(s) Shipped Loose (STD)
B=Cotter Pins & Clevis Pin(s) Installed
C=No Retainers, Clevis Pin(s) Shipped Loose if Selected

AVAILABLE CLEVIS PIN OPTIONS	CYLINDER BORE SIZE (Inch)						
	2.00	2.50	3.00	3.50	4.00	4.50	5.00
1.00"Ø PIN	S	S	S	S			
1.00"Ø HARDENED PIN	O	O	O	O	S		
1.25"Ø HARDENED PIN					O	S	S

CLEVIS PIN OPTIONS & AVAILABILITY: (See Table Above)

A=2-1.00"Ø Pins	E=1-1.00"Ø Pin
B=Reserved	F=Reserved
C=2-1.00"Ø Hardened Pins	G=1-1.00"Ø Hardened Pin
D=2-1.25"Ø Hardened Pins	H=1-1.25"Ø Hardened Pin
	J= No Pins

END FITTING OPTIONS: (See Table Above)

A=Ø1.00" Pin Holes, Both Ends
B=Ø1.00" Base End Pin Hole, No Rod Clevis
C=Ø1.00" Pin Holes, Both Ends, Stroke Control Assy *
D=Ø1.25" Pin Holes, Both Ends
E=Ø1.25" Base End Pin Hole, No Rod Clevis
*(ASAE Version 2.0-3.5" Bore with 8" stroke only)