

Functional Group:
 Products : Accessories : Cartridge Seal Kits

Model:
 990-103-006

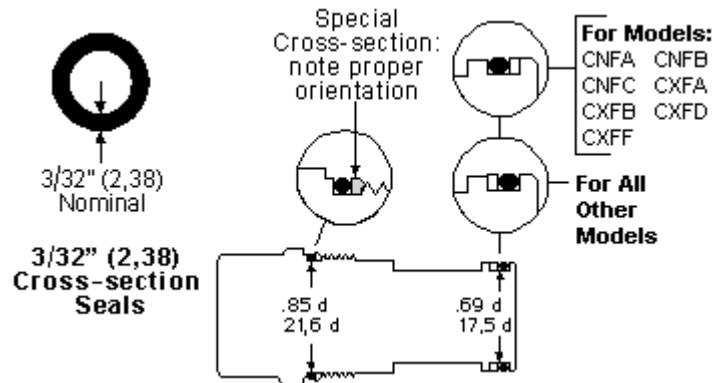

Technical Data

	U.S. Units	Metric Units
Installation Torque	45 - 50 lbf ft	60 - 70 Nm
Title	Viton Seal Kit	
Valve Hex Size	1 1/8 in.	28,6 mm

Option Selection:

990-103-006

Related Information

[Seal Kit General Guidelines](#)

[Explanation of Sun Hydraulics Date Code](#)

[1985 Design Change to Series 2 Cartridges](#)

Instructions

- | Install back-up rings and O-rings as shown in views.
- | When installing continuous back-up rings, use the same technique and the same care used to install O-rings.
- | When installing cartridge - be sure to torque to recommended value.
- | When replacing a spiral backup ring, take special care that the SPIRAL IS WOUND LIKE A LEFT-HAND THREAD, so that the backup ring will follow the cartridge into the cavity properly when being assembled.