

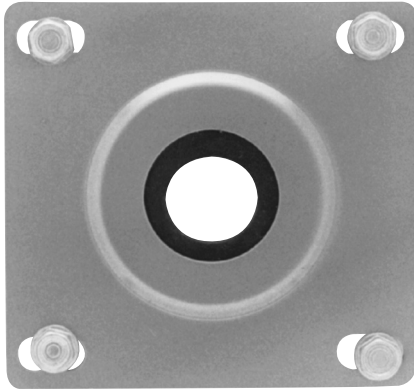

# SUCTION FLANGES FOR PIPE/TUBING



- VESCOR Suction Flanges are designed to seal suction lines passing through the top plate of a hydraulic reservoir or similar application
- VESCOR Suction Flanges also allow access for removal of suction elements for inspection and cleaning

### Each Suction Flange Assembly Includes:

1. (1) Top plate
2. (1) Internal washer
3. (1) Bottom plate
4. (1) Gasket
5. (4) 5/16-18 thread forming screws

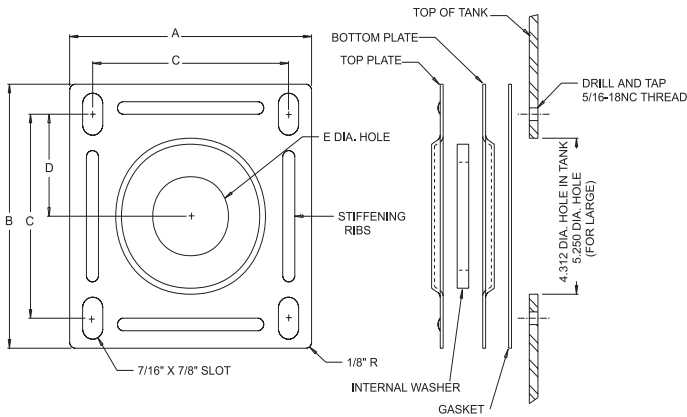

Vescor Part Numbers 5100-5179 and 5880-5891

Vescor Part Number	Flange Dimensions (inches)					Pipe Size
	A	B	C	D	E	
5100	5¼"	5½"	4¼"	2⅛"	1⅜"	½"
5101	5¼"	5½"	4¼"	2⅛"	1⅜"	¾"
5102	5¼"	5½"	4¼"	2⅛"	1¾"	1"
5103	5¼"	5½"	4¼"	2⅛"	1¾"	1¼"
5104	5¼"	5½"	4¼"	2⅛"	2½"	1½"
5105	5¼"	5½"	4¼"	2⅛"	2½"	2"
5187	7¼"	7½"	6¼"	3⅛"	3⅛"	1½"
5188	7¼"	7½"	6¼"	3⅛"	3⅛"	2"
5178	7¼"	7½"	6¼"	3⅛"	3¾"	2½"
5179	7¼"	7½"	6¼"	3⅛"	3¾"	3"
5180	7¼"	7½"	6¼"	3⅛"	4¾"	3½"
5181	7¼"	7½"	6¼"	3⅛"	4¾"	4"

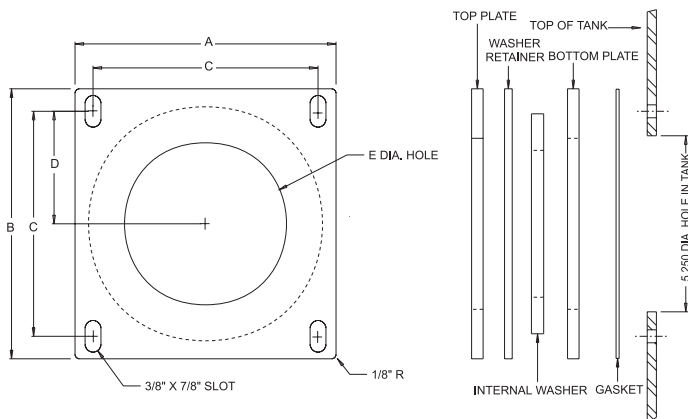

Vescor Part Numbers 5180-5181

Vescor Part Number	Flange Dimensions (inches)					Tube Size O.D.
	A	B	C	D	E	
5891	5¼"	5½"	4¼"	2⅛"	1⅜"	⅜"
5880	5¼"	5½"	4¼"	2⅛"	1⅜"	½"
5881	5¼"	5½"	4¼"	2⅛"	1⅜"	⅝"
5882	5¼"	5½"	4¼"	2⅛"	1⅜"	¾"
5883	5¼"	5½"	4¼"	2⅛"	1¾"	1"
5884	5¼"	5½"	4¼"	2⅛"	1¾"	1¼"
5885	5¼"	5½"	4¼"	2⅛"	2½"	1½"



# RETURN FLANGES AND GROMMETS

## Return Flanges for Pipe and Tube

Each Return Flange Assembly Includes:

1. (1) Flange
2. (1) Internal washer
3. (2) 1/4-20 thread forming screws

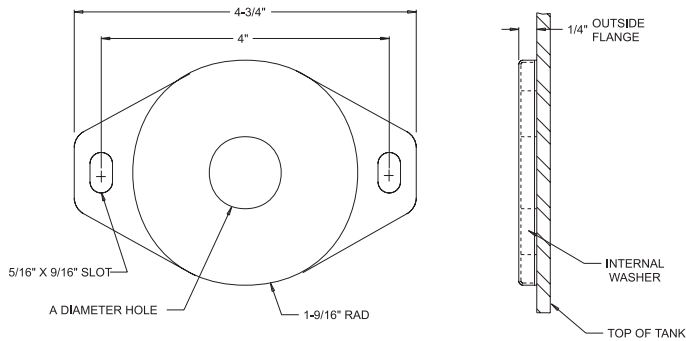
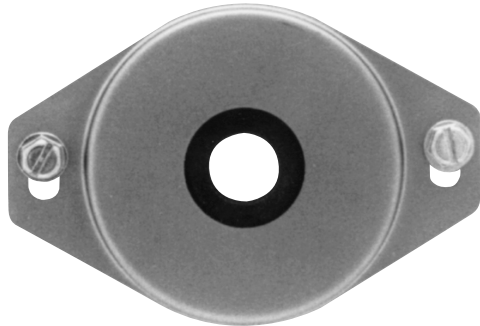

### Return Flanges for Pipe

Vescor Part Number	A Diameter Hole	Pipe Size
5110	1 <sup>3</sup> / <sub>16</sub> "	1/2"
5111	1 <sup>3</sup> / <sub>4</sub> "	3/4"
5112	1 <sup>3</sup> / <sub>4</sub> "	1"
5113	2 <sup>1</sup> / <sub>2</sub> "	1 <sup>1</sup> / <sub>4</sub> "
5114	2 <sup>1</sup> / <sub>2</sub> "	1 <sup>1</sup> / <sub>2</sub> "
5115	2 <sup>1</sup> / <sub>2</sub> "	2"

### Return Flanges for Tube

Vescor Part Number	A Diameter Hole	Tube Size O.D.
5772	1 <sup>3</sup> / <sub>16</sub> "	3/8"
5765	1 <sup>3</sup> / <sub>16</sub> "	1/2"
5766	1 <sup>3</sup> / <sub>16</sub> "	5/8"
5767	1 <sup>3</sup> / <sub>16</sub> "	3/4"
5768	1 <sup>3</sup> / <sub>4</sub> "	1"
5769	2 <sup>1</sup> / <sub>2</sub> "	1 <sup>1</sup> / <sub>4</sub> "
5770	2 <sup>1</sup> / <sub>2</sub> "	1 <sup>1</sup> / <sub>2</sub> "
5771	2 <sup>1</sup> / <sub>2</sub> "	2"

## Rubber Grommets for Reservoir Downpipes



**Material Specifications: BUNA-N**

1. Drill hole in tank top per cutout size "F"
2. Snap in grommet.
3. Blank size with 'E' hole shall be furnished.  
Maximum O.D. limited to 'B' dimension.

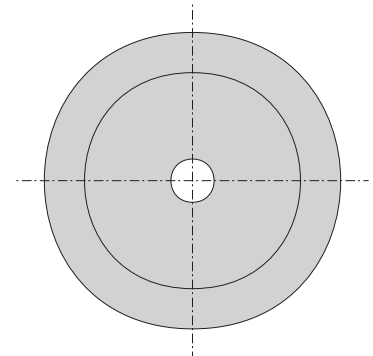

Vescor Part Number	Dimensions					Cutout Size F
	A	B	C	D	E	
131499	1 <sup>7</sup> / <sub>8</sub> "	2 <sup>5</sup> / <sub>32</sub> "	5/8"	1"	1/4"	1 <sup>1</sup> / <sub>8</sub> "
131599	2 <sup>3</sup> / <sub>8</sub> "	1 <sup>13</sup> / <sub>64</sub> "	5/8"	1"	1/4"	1 <sup>7</sup> / <sub>16</sub> "
131699	3"	1 <sup>27</sup> / <sub>32</sub> "	5/8"	1"	3/8"	2 <sup>1</sup> / <sub>16</sub> "
131799	3 <sup>1</sup> / <sub>2</sub> "	2 <sup>13</sup> / <sub>32</sub> "	5/8"	1"	1/2"	2 <sup>5</sup> / <sub>8</sub> "
131899	4 <sup>1</sup> / <sub>2</sub> "	3 <sup>1</sup> / <sub>2</sub> "	1 <sup>1</sup> / <sub>16</sub> "	1 <sup>3</sup> / <sub>16</sub> "	1/2"	3 <sup>7</sup> / <sub>8</sub> "

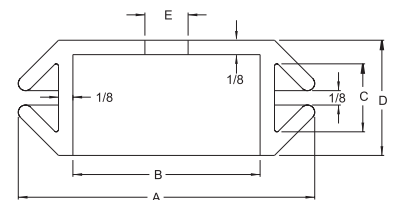



# RISERS

## Filler Breather Riser

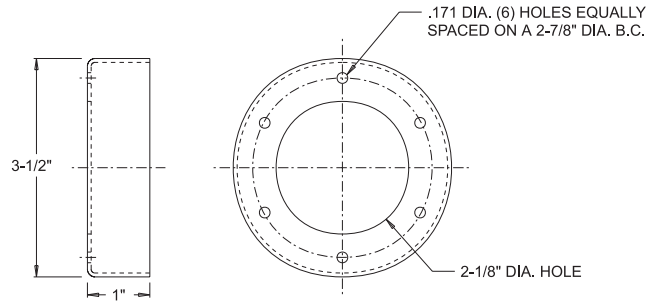

- VESCOR® Filler Breather Weld Riser is designed to raise filler breathers 1" above the mounting surface of the reservoir
- Eliminate the need to drill and tap tank top. Just weld in place
- Prevent contamination from entering reservoir
- Round design
- Use with VESCOR® bayonet filler breathers

Vescor Part Number	Style	Description
5275	Round	Filler Breather Weld Riser

## Suction Flange Riser

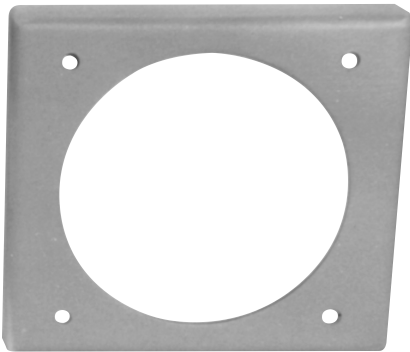

- VESCOR® Suction Flange Risers are designed to raise suction flanges 1" above the mounting surface of the reservoir
- Prevents contamination from entering the reservoir
- Use with VESCOR® Suction Flanges

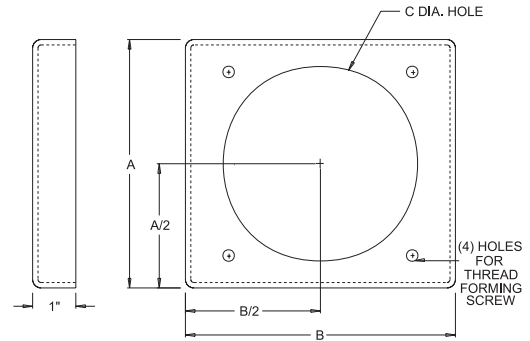

Vescor Part Number	A Dimension	B Dimension	C Diameter	Use with Pipe/Tube
5150	5 3/4"	6 1/4"	4 1/2"	1/2" to 2"
5151	7 3/4"	8 1/4"	6 1/2"	1 1/2" to 4"

## Return Flange Riser



- VESCOR® Return Flange Risers are designed to raise return flanges 1" above the mounting surface of the reservoir
- Prevents contamination from entering reservoir
- Use with VESCOR® Return Flanges

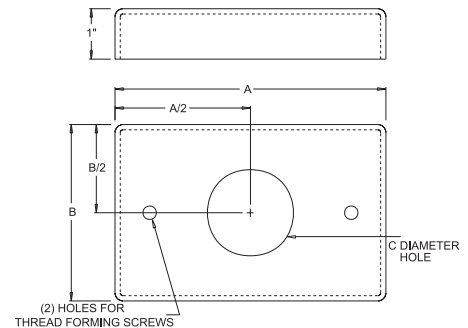

Vescor Part Number	A Dimension	B Dimension	C Diameter	Use with Pipe	Use with Tube
5156	5 3/8"	3 1/2"	1 13/16"	1/2" to 1 1/2"	3/8" to 1 1/2"
5157	5 3/8"	4"	2 9/16"	2"	2"