

# CPIFF Inline Check Valves

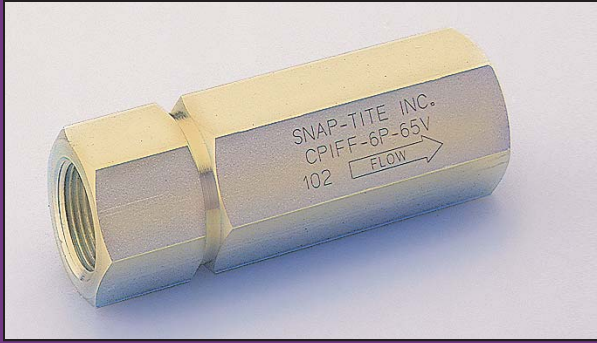

- ◆ Poppet style – soft seat
- ◆ Flow rates to 30 gpm (115 l/min)
- ◆ Steel Construction; other materials available
- ◆ Five sizes - 1/4", 3/8", 1/2", 3/4", 1"
- ◆ SAE, NPSF & BS 2779 female end fittings
- ◆ Up to 5000 psi (345 bar) working pressure

## Features

The soft seat (virtual zero leak) guided poppet design and 4:1 safety factor of Snap-tite's Inline Check Valves make them an excellent choice for a wide variety of applications where free flow in one direction and blocked flow in the reverse direction is required. The streamlined soft seated poppet offers minimum restriction to flow and positive shut off. These valves can be provided with various spring pressures and seal options compatible with most types of fluids.



## †Notes:

- Decimal dimensions are +/- .015 in. (.38 mm).
- Ratings, specifications, and dimensions are subject to change without notice.
- Part configurations are typical and do not necessarily represent actual appearance.
- Consult factory for certified drawing of 6C/3C end fitting configurations.

## †Flow Direction



## Dimensions and Specifications

Size		1/4"	3/8"	1/2"	3/4"	1"
Hex	In.	.75	1.00	1.25	1.38	1.75
	mm	19.05	25.40	31.75	35.05	44.45
Length	In.	1.97	2.60	3.25	4.33	4.78
	mm	50.04	66.04	82.55	109.98	121.41
Cv		.60	1.20	2.40	4.10	7.15
Weight	lbs.	.20	.25	.90	1.25	2.25
	kg.	.09	.11	.41	.57	1.02
Flow	gpm	3.00	8.00	12.00	20.00	30.00
	l/min.	11.40	30.30	45.40	75.70	113.55

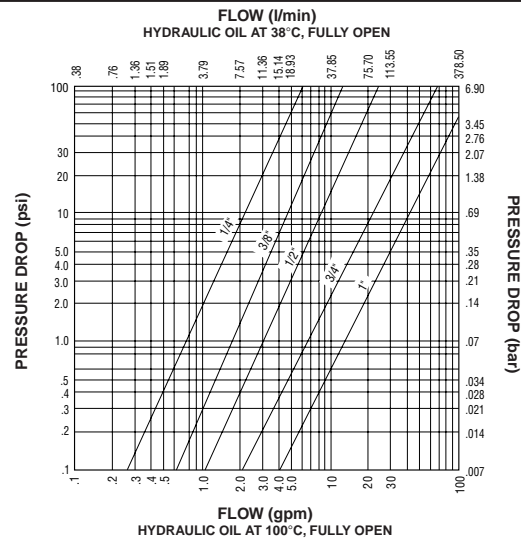

# 6C/3C Inline Check Valves



- ◆ Poppet style – soft seat
- ◆ Steel or stainless steel construction; other materials available
- ◆ Flow rates to 175 gpm (662 l/min)
- ◆ SAE, NPSF, NPT, BS 2779 & ORS end fittings available
- ◆ Up to 6000 psi (414 bar) working pressure - 1/4", 3/8", 1/2", 3/4" & 1"
- ◆ Up to 3000 psi (207 bar) working pressure - 1-1/4", 1-1/2" & 2"

## Features

These soft seat (virtual zero leak), with guided poppet valves offer a wide variety of end fitting configurations and elastomers and the option of 316 stainless steel construction. These options enable a valve to be configured to meet the needs of any system. Snap-tite's versatile 6C/3C Inline Check Valves are designed with a 4:1 safety factor at a maximum working pressure of 6000 psi (414 bar) making them ideal for any application.



## \*Dimensions and Specifications

Size	1/4"	3/8"	1/2"	3/4"	1"	1-1/4"	1-1/2"	2"	
Hex	In.	.75	1.12	1.25	1.62	1.88	2.00	2.50	3.25
	mm	19.05	28.45	31.75	41.15	47.75	50.80	63.50	82.55
Length	In.	2.82	3.38	3.73	4.91	6.07	5.76	6.51	7.28
	mm	71.60	85.85	94.75	124.70	154.20	146.30	165.35	184.90
Cv		.45	1.80	3.40	7.40	9.50	12.30	16.15	21.80
Weight	lbs.	.29	.81	1.20	2.05	3.40	3.75	7.80	13.00
	kg.	.13	.37	.54	.93	1.54	1.70	3.54	5.90
Flow	gpm	3.00	8.00	12.00	20.00	30.00	90.00	125.00	175.00
	l/min.	11.40	30.30	45.45	75.70	113.55	340.65	473.15	662.40

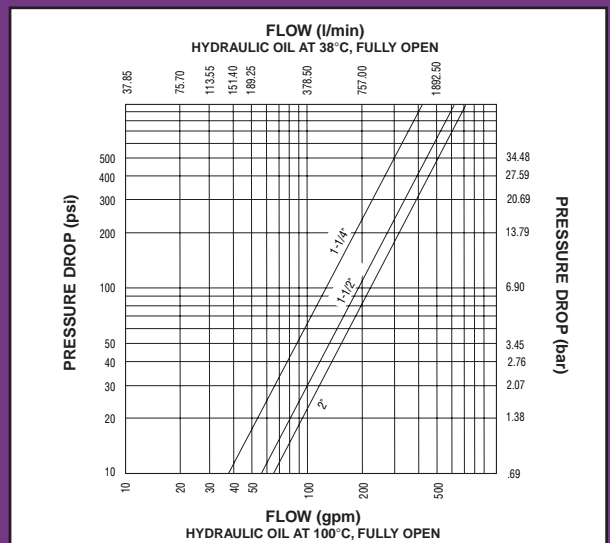
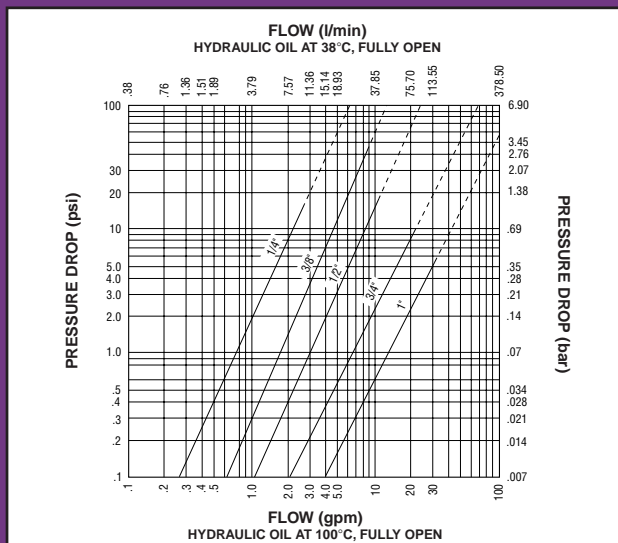

# CPC Check Valve Cartridge



- ◆ 3500 psi (241 bar) working pressure
- ◆ Flow rates to 50 gpm (189 l/min)
- ◆ Steel Construction
- ◆ Three standard spring pressures
- ◆ Three sizes based on flow

## Features

Designed for hydraulic circuit applications where virtually zero leakage in the check direction is required. The drop-in cartridge design with soft poppet seal of molded nylon is available in three sizes with flow ratings of 10 gpm (38 l/min), 25 gpm (95 l/min), and 50 gpm (189 l/min) respectively.

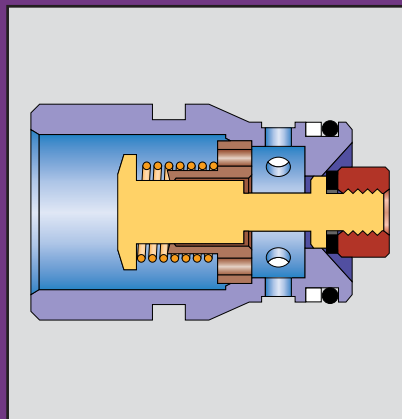

## \*Dimensions and Specifications

Model		A	B	C	D	E	F	G	H	J	K	L	M	N
CPC 10	In.	1.204	.248	.500	.629/.625	.250	.390	.745/.750	.437	.030	.300	1.20	.74	.62
	mm	30.6	6.3	12.7	16.0/15.9	6.4	9.9	18.9/19.0	11.0	.76	7.6	30.5	18.8	15.7
CPC 25	In.	1.776	.230	.680	.879/.875	.531	.520	1.004/1.000	.500	.025	.400	1.78	.99	.87
	mm	45.1	5.8	17.3	22.3/22.2	13.5	13.2	25.5/25.4	12.7	.64	10.2	45.2	25.1	22.1
CPC 50	In.	2.291	.284	1.060	1.316/1.312	.592	.600	1.504/1.500	1.000	.025	.476	2.29	1.49	1.30
	mm	58.2	7.2	26.9	33.4/33.3	15.1	15.2	38.2/38.1	25.4	.64	12.1	58.2	37.8	33.0

## ^Notes:

- Decimal dimensions are +/- .015 in. (.38 mm).
- Ratings, specifications, and dimensions are subject to change without notice.
- Part configurations are typical and do not necessarily represent actual appearance.
- Consult factory for certified cavity drawing.

## CPC Flow Direction:

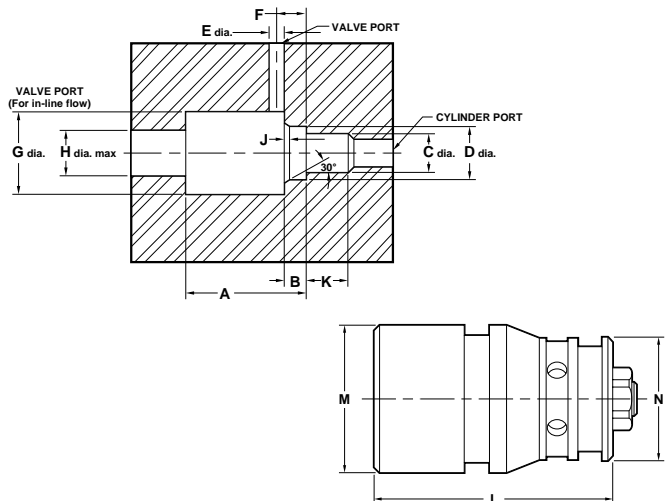
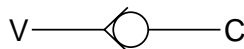

# CAD Dual Pilot Check Valve



- ◆ 3500 psi (241 bar) 5000 psi (345 bar) intermittently
- ◆ Flow rates to 50 gpm (189 l/min)
- ◆ Anodized aluminum blocks, plated steel cartridges
- ◆ Three standard spring pressures
- ◆ Three sizes based on flow
- ◆ Pilot ratio - 4:1

## Features

The CAD dual pilot check valve features two CAC check cartridges in a single red anodized aluminum housing with standard ports to 1" in NPSF or SAE o-ring sealed. Flow into one of the valve ports is blocked until pressure overcomes the poppet spring. When the poppet is unseated, flow is permitted to the actuator; simultaneously the pilot piston on the actuated side unseats the opposite poppet to permit return flow through the valve.

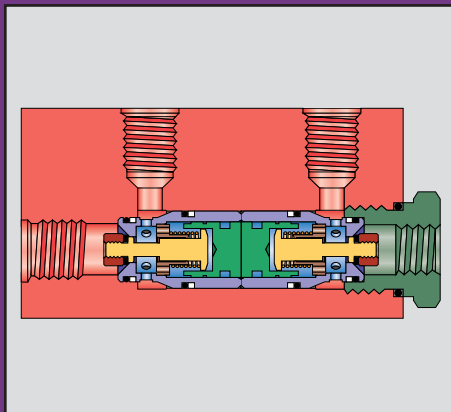

## \*Dimensions and Specifications

Model		A	B	C	D	E	F	G	H	J	K	L	M	N
CAD 10 1/4" & 3/8"	In.	3.96	3.59	2.00	1.25	.63	1.38	1.65	.68	1.00	1.50	1.62	.50	.34
	mm	100.6	91.2	50.8	31.8	16.0	35.1	41.9	17.3	25.4	38.1	41.1	12.7	8.6
CAD 10 1/2"	In.	4.60	3.59	2.00	1.25	.63	1.38	1.65	.68	1.00	1.50	1.62	.50	.34
	mm	116.8	91.2	50.8	31.8	16.0	35.1	41.9	17.3	25.4	38.1	41.1	12.7	8.6
CAD 25 3/8", 1/2", 3/4"	In.	5.78	5.21	2.00	1.50	.75	1.25	2.60	.86	1.19	2.15	2.56	.30	.41
	mm	146.8	132.3	50.8	38.1	19.0	31.8	66.0	21.8	30.2	54.6	65.0	7.6	10.4
CAD 25 3/4 SAE	In.	6.33	5.21	2.50	1.50	.75	1.75	2.59	.85	1.38	2.15	2.56	.30	.41
	mm	160.8	132.3	63.5	38.1	19.0	44.5	65.8	21.6	35.1	54.6	65.0	7.6	10.4
CAD 50	In.	7.13	6.24	3.00	2.00	1.00	2.00	3.46	.98	1.75	2.75	3.00	.50	.41
	mm	181.1	158.5	76.2	50.8	25.4	50.8	87.9	24.9	44.5	69.9	76.2	12.7	10.4

## CAD Series

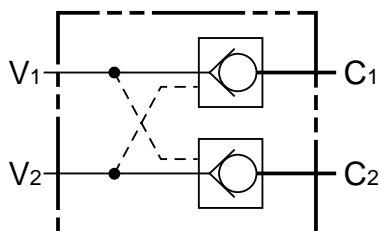

## Adaptor Torque

CAD 10 = 180 lbf. In. (20.3 N.m)  
 CAD 25 = 480 lbf. In. (54.2 N.m)  
 CAD 50 = 750 lbf. In. (85.0 N.m)

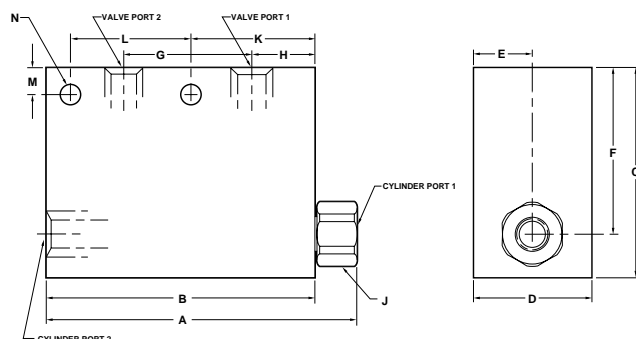

# CAV Single Pilot Check Valve



- ◆ 3500 psi (241 bar), 5000 psi (345 bar) intermittently
- ◆ Flow rates to 50 gpm (189 l/min)
- ◆ Anodized aluminum blocks, plated steel cartridges
- ◆ Three standard spring pressures
- ◆ Three sizes based on flow
- ◆ Pilot ratio - 4:1

## Features

The CAV single pilot check valve contains a standard CAC cartridge in a red anodized aluminum block with NPSF or SAE porting to 1". Units are available with three standard cracking pressures of 15 psi (1 bar), 25 psi (1.7 bar), or 60 psi (4 bar).

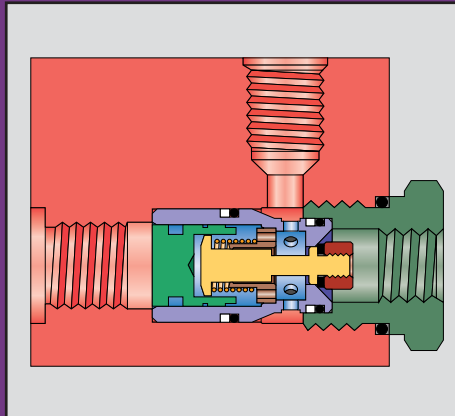

## \*Dimensions and Specifications

Model		A	B	C	D	E	F	G	H	J	K	L	M
CAV 10 1/4" & 3/8"	IN.	2.77	2.40	2.00	1.25	.63	1.38	.69	1.00	1.50	.65	.50	.34
	MM	70.4	61.0	50.8	31.8	16.0	35.1	17.5	25.4	38.1	16.5	12.7	8.6
CAV 10 1/2"	IN.	3.41	2.40	2.00	1.25	.63	1.38	.69	1.00	1.50	.65	.50	.34
	MM	86.6	61.0	50.8	31.8	16.0	35.1	17.5	25.4	38.1	16.5	12.7	8.6
CAV 25 3/8", 1/2", 3/4"	IN.	3.73	3.15	2.00	1.50	.75	1.25	.86	1.19	1.80	1.00	.30	.41
	MM	94.7	80.0	50.8	38.1	19.0	31.8	21.8	30.2	45.7	25.4	7.6	10.4
CAV 25 3/4 SAE	IN.	4.55	3.43	2.50	1.50	.75	1.75	.85	1.38	1.88	1.25	.75	.41
	MM	115.6	87.1	63.5	38.1	19.0	44.5	21.6	35.1	47.8	31.8	19.0	10.4
CAV 50	IN.	4.55	3.65	3.00	2.00	1.00	2.00	.96	1.75	2.25	1.00	.50	.41
	MM	115.6	92.7	76.2	50.8	25.4	50.8	24.4	44.5	57.2	25.4	12.7	10.4

## Adaptor Torque

CAV 10 = 180 lbf. In. (20.3 N.m)

CAV 25 = 480 lbf. In. (54.2 N.m)

CAV 50 = 750 lbf. In. (85.0 N.m)

## Flow Direction:

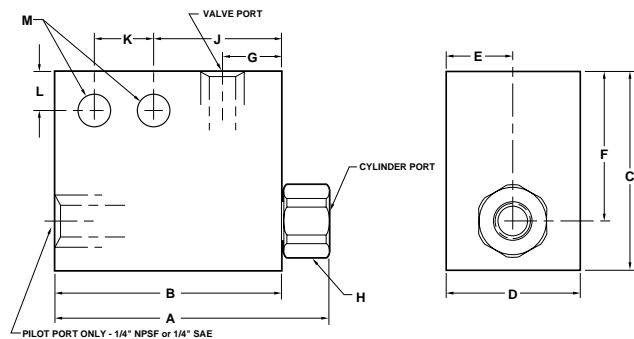
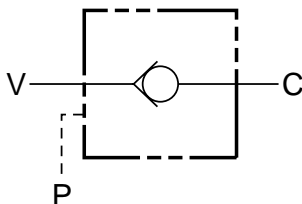

# CAC Pilot Check Valve Cartridge



- ◆ 3500 psi (241 bar) working pressure, 5000 psi (345 bar) intermittently
- ◆ Flow rates to 50 gpm (189 l/min)
- ◆ Steel Construction
- ◆ Three standard spring pressures
- ◆ Pilot ratio - 4:1
- ◆ Air Pilot option available

## Features

Designed for use in hydraulic circuits requiring less than 1 DPM leakage. These drop-in cartridge valves lock an actuator or part of a circuit until pilot pressure is applied. Features include durable molded nylon poppet seal, damping port in poppet guide, hardened steel body and poppet.

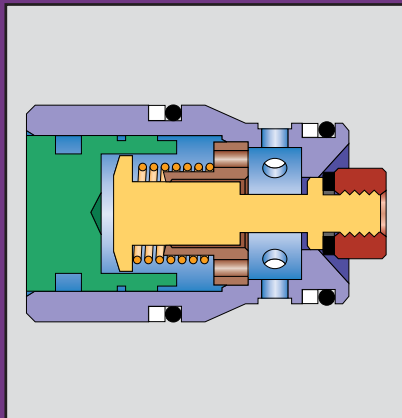

## \*Dimensions and Specifications

Model		A	B	C	D	E	F	G	H	J	K	L	M	N
CAC 10	IN.	1.204	.248	.500	.629/.625	.250	.390	.745/.750	.437	.030	.300	1.20	.74	.62
	MM	30.6	6.3	12.7	16.0/15.9	6.4	9.9	18.9/19.0	11.0	.76	7.6	30.5	18.8	15.7
CAC 25	IN.	1.776	.230	.680	.879/.875	.531	.520	1.004/1.000	.500	.025	.400	1.78	.99	.87
	MM	45.1	5.8	17.3	22.3/22.2	13.5	13.2	25.5/25.4	12.7	.64	10.2	45.2	25.1	22.1
CAC 50	IN.	2.291	.284	1.060	1.316/1.312	.592	.600	1.504/1.500	1.000	.025	.476	2.29	1.49	1.30
	MM	58.2	7.2	26.9	33.4/33.3	15.1	15.2	38.2/38.1	25.4	.64	12.1	58.2	37.8	33.0

## CPC/CAC Pressure Drop

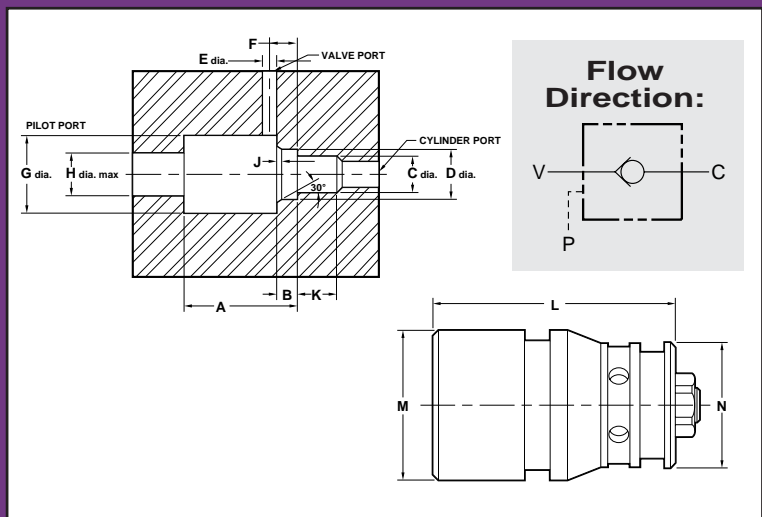
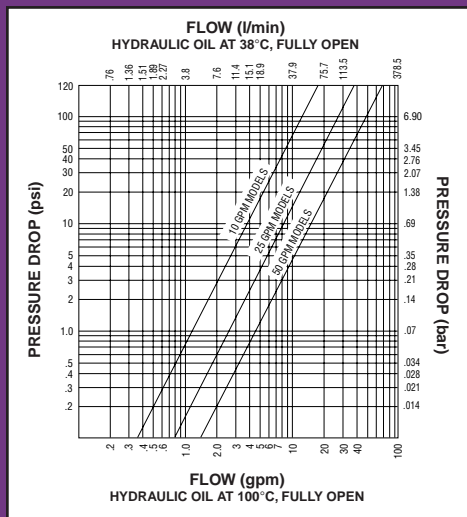



# Ordering Information

## Inline Check Valves - 5,000 psi (345 bar) rated

### CPI F F - 4 P - 15

Series	Inlet	Outlet	Port Size	Thread Type	Spring Pressure	Seal	
CPI - Inline Check Valve Poppet Style	F - Female	F - Female	NPSF or BSP 2 - 1/4" 3 - 3/8" 4 - 1/2" 6 - 3/4" 8 - 1"	SAE 8 - 1/2" 12 - 3/4" 16 - 1"	RP - Female British Parallel BS 2779 P - Female NPSF S - Female SAE	05 - 5 psi (.35 bar) 15 - 15 psi (1 bar) 25 - 25 psi (1.75 bar) 65 - 65 psi (4.50 bar)	No letter for Viton (std.) A - Buna E - Ethylene Propylene

## Inline Check Valves - Up to 6,000 psi (414 bar) rated\*

### S 6C 4 F - F 5

Material	Check Valve	Size	Inlet	Outlet	Spring Pressure	Seal
No letter Steel Zinc Yellow Dichromate Plated (standard) S - 316 Stainless Steel	6C - 6,000 psi* (414 bar) operating pressure 3C - 3,000 psi (207 bar) operating pressure	4 - 1/4" 6 - 3/8" 8 - 1/2" 12 - 3/4" 16 - 1" 20 - 1-1/4" 24 - 1-1/2" 32 - 2"	M - Male NPT F - Female NPTF EF - Female SAE EM - Male 37° Flare ORS - Male Face Seal RP - Female British Parallel BS 2779	M - Male NPT F - Female NPTF EF - Female SAE EM - Male SAE 37° Flare ORS - Male Face Seal RP - Female British Parallel BS 2779	5 - 5 psi (.35 bar) 25 - 25 psi (1.75 bar) 65 - 65 psi (4.5 bar)	No letter for Viton (std.) M - Military variation of Buna N for MIL-H-5606 fluids A - Buna E - Ethylene Propylene

### CAC 10 - 15 - A - 1

Series	Rated Flow	Cracking Pressure	Seal	Air Pilot* Option	Current Design
CAC - Poppet Cartridge Pilot Check Valve CPC - Poppet Cartridge Check Valve	10 - 10 gpm (38 l/min) 25 - 25 gpm (95 l/min) 50 - 50 gpm (189 l/min)	15 - 15 psi (1 bar) 25 - 25 psi (1.7 bar) 60 - 60 psi (4 bar)	No letter for Viton A - Buna N	P - O-ring on Pilot Piston [60 psi (4 bar) spring is recommended] *CAC only	- 1

### CAV 10 - 3P - 15 A

Series	Rated Flow	Port Size	Cracking Pressure	Air Pilot	Seal
CAV - Single Pilot Operated Check Valve CAD - Dual Pilot Operated Check Valve	10 - 10 gpm (38 l/min) 1/4", 3/8", 1/2" ports 25 - 25 gpm (95 l/min) 3/8", 1/2", 3/4" ports 50 - 50 gpm (189 l/min) 3/4", 1" ports	NPT SAE 2P - 1/4" 4S - 1/4" 3P - 3/8" 6S - 3/8" 4P - 1/2" 8S - 1/2" 6P - 3/4" 12S - 3/4" 8P - 1" 16S - 1"	15 - 15 psi (1 bar) 25 - 25 psi (1.7 bar) 60 - 60 psi (4 bar)	P - O-ring on Pilot Piston [60 psi (4 bar) spring is recommended]	No letter for Viton A - Buna N

\*3/4" 6C SST working pressure - 5000 psi (345 bar), 1" 6C SST working pressure - 4000 psi (276 bar)

## ! WARNING !

FAILURE OR IMPROPER SELECTION OR IMPROPER USE OF THE PRODUCTS AND/OR SYSTEMS DESCRIBED HEREIN OR RELATED ITEMS CAN CAUSE DEATH, PERSONAL INJURY AND PROPERTY DAMAGE.

This document and other information from Snap-tite, Inc., its subsidiaries and authorized distributors provide product and/or system options for further investigation by users having technical expertise. It is important that you analyze all aspects of your application and review the information concerning the product or system in the current product catalog. Due to the variety of operation conditions and applications for these products or systems, the user, through its own analysis and testing, is solely responsible for making the final selection of the products and systems and assuring that all performance, safety and warning requirements of the application are met.

The products described herein, including without limitation, product features, specifications, designs, availability and pricing, are subject to change by Snap-tite, Inc. and its subsidiaries at any time without notice.



Quick Disconnect & Valve Division  
201 Titusville Road  
Union City, Pennsylvania 16438-8699 USA  
PH: 814-438-3821 FAX: 814-438-3069  
e-mail: qd&v\_sales@snap-tite.com  
www.snap-tite.com



Industrial Estate  
Whitemill - Wexford  
Republic of Ireland  
PH: 353-53-41566 FAX: 353-53-41582  
e-mail: ste\_sales@snap-tite.com  
www.snap-tite.com

Distributed by:

ISO-9001 Certified