

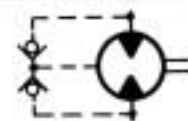

# HYDRAULIC MOTORS

## GEAR MOTORS 40 SERIES Specification Sheet



The CROSS series 40 hydraulic gear type motors feature advanced design concepts which produce long service life and high reliability when operated up to rated speeds and pressures. Improved gear tooth design and pressure-balanced loading plates provide for a high volumetric and overall efficiency, while operating at a low noise level.

### GENERAL SPECIFICATIONS

Displacement sizes

0.50	0.75	1.00	1.25	1.50	1.80	cu.in./Rev.
8.2	12.3	16.4	20.5	24.6	29.5	cc/Rev.

Rated working pressure (Max. relief valve setting at full flow) . . . . . 3000 psi (207 bar)  
 Maximum shock and surge pressure . . . . . 3500 psi (242 bar)  
 Maximum flow rate (input) . . . . . 20.45 gpm (77.4 l/m)  
 Maximum speed (continuous) . . . . . up to 4000 rpm  
 Maximum horsepower (at rated speed and pressure) . . . . . 49 hp (36.5 Kw)  
 Mounting (any position) . . . . . SAE "A" size, 2-bolt  
 Weight . . . . . Approx. 7 lbs. (3.2 Kg)

### MATERIAL SPECIFICATIONS

Body and end covers . . . . . Die cast aluminum alloy  
 Gears . . . . . Sintered metal  
 Shaft . . . . . Hardened steel  
 Bearings . . . . . Pressure lubricated, Teflon impregnated sleeve  
 Seals . . . . . Buna N

### STANDARD FEATURES

- Rotation: Bi-directional (Dual Rotation)
- Ports: 3/4" SAE #12 straight thread o-ring (1 1/16 - 12) • 1/4" NPTF Drain port
- Internal check valves (no external drain required if back pressure is below shaft seal rating)
- Shaft: 5/8" dia. Woodruff keyed (short) • Shaft Seal: 250 psi (17 bar)

### OPTIONAL FEATURES AVAILABLE

- Rotation: Right hand (clockwise); Left hand (counterclockwise)
- Ports: Rear inlet and outlet location
- Shafts: 5/8" dia. splined (9 tooth); 5/8" dia. keyed (long); 3/4" dia. keyed (long)

NOTE: Refer to CROSS pump and motor technical/service sheet for side and end load limitations, oil and filter recommendations, start-up procedures, etc.



**DIMENSIONAL DATA in inches and (millimeters)**

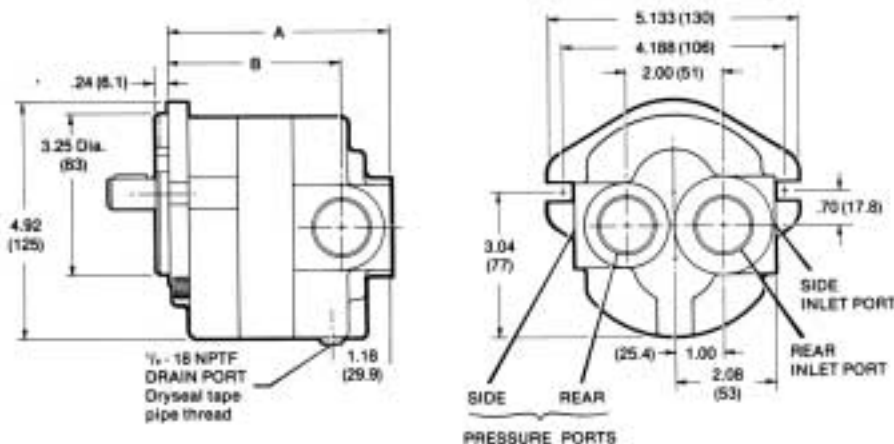

Displacement cu in./Rev. (cc/Rev.)	Dim. "A" Inches (mm)	Dim. "B" Inches (mm)
.50 (8.2)	4.25 (107)	3.23 (82)
.75 (12.3)	4.44 (112)	3.42 (86)
1.00 (16.4)	4.62 (117)	3.60 (91)
1.25 (20.5)	4.81 (122)	3.79 (96)
1.50 (24.6)	4.99 (126)	3.97 (100)
1.80 (29.5)	5.22 (132)	4.20 (106)

**OUTPUT SHAFT**

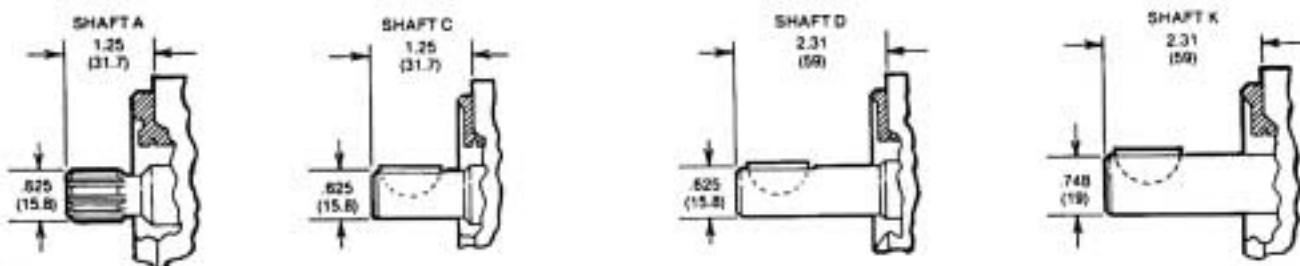

SHAFT "A": 9 tooth, 16/32 pitch, 30° pressure angle, flat root side fit, Class 1.  
 SHAFT "C", "D" and "K" : Woodruff key - 3/16" dia. x 3/32.

**ORDERING DATA**

Series	Type	Special Options	Size cu.in./R x 10	Rotation	Mounting	Shaft Size & Type		PORTS LOCATION and SIZE				
						A	K	Inlet	Outlet			
40	M motor	H 250 psi shaft seal	5	D dual	A SAE "A" 2-bolt	A 3/8" spline	K 3/8" dia. keyed (long)	SC	1 1/16	1 1/16	SIDE PORTS	
			7						RD	1 1/16		1 1/16
			10									
			12									
			15									
18	R right	D 3/8" dia. keyed (long)			REAR PORTS							

**EXAMPLE: 40MH12DACSC**

Describes a Series 40 Gear Motor, 250 psi shaft seal, displacement of 1.2 cu. in. per revolution; bi-directional rotation; SAE "A" 2-Bolt Mount; 3/8" dia. keyed shaft and 1 1/16-12 side ports.



### TYPICAL PERFORMANCE DATA

(FOR SPECIFIC PERFORMANCE DATA,  
CONTACT CROSS ENGINEERING)

#### MODEL 40M005

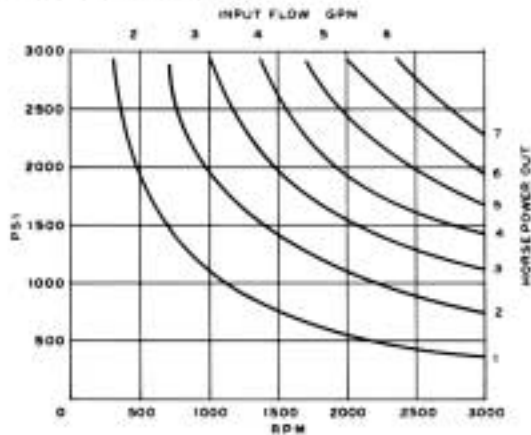

#### MODEL 40M012

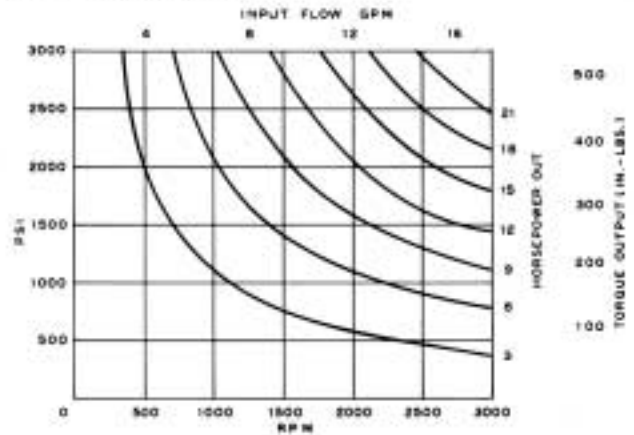

#### MODEL 40M007

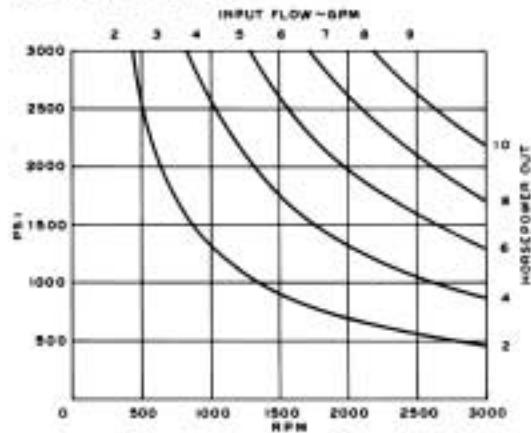

#### MODEL 40M015

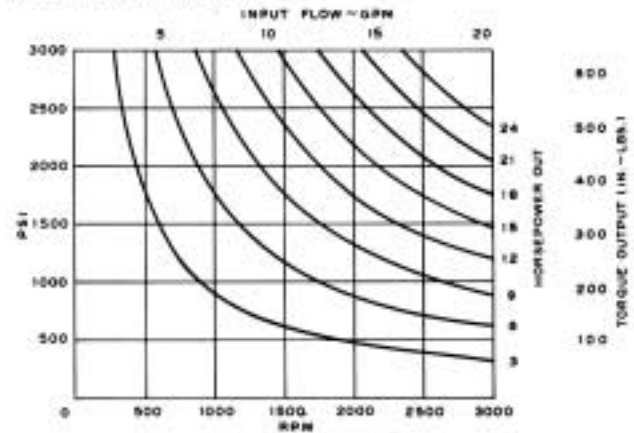

#### MODEL 40M010

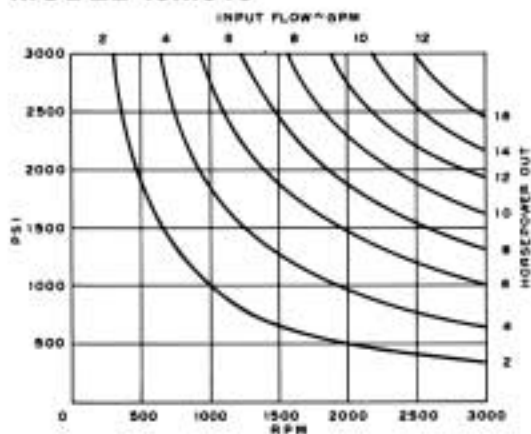

#### MODEL 40M018

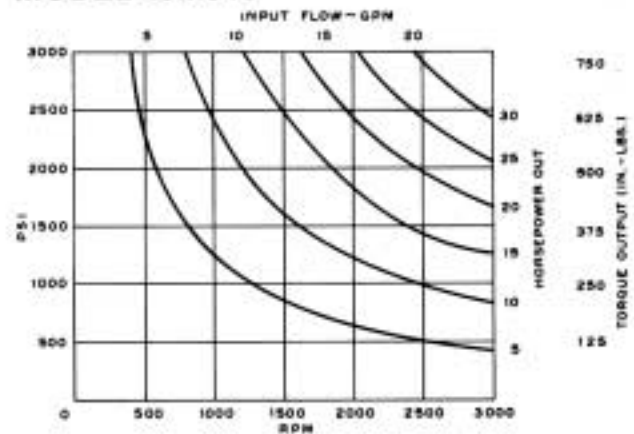



**TYPICAL PERFORMANCE DATA**

**STARTING ENGINE TORQUE (in.-lbs.) vs. PRESSURE (PSI)**

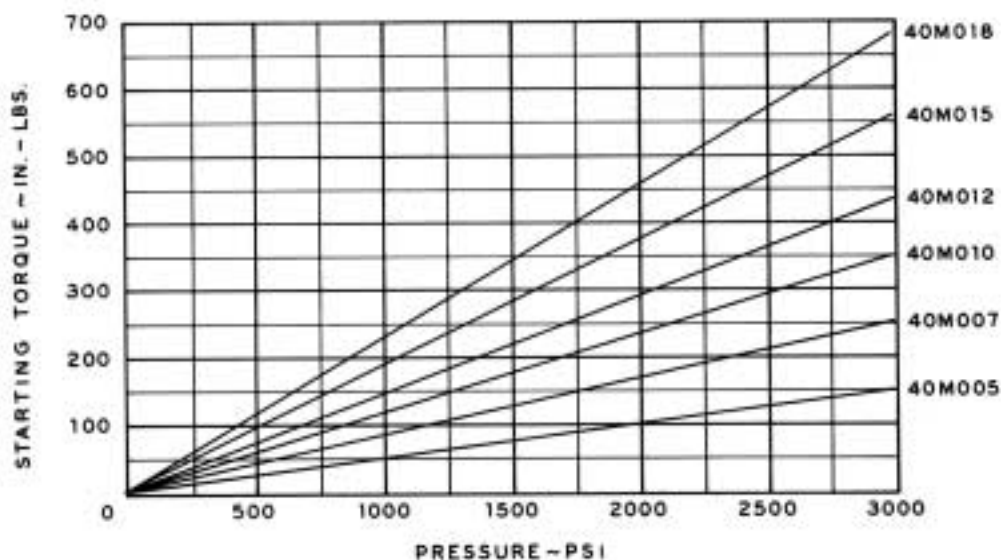

**VOLUMETRIC EFFICIENCY (%) vs. RPM  
(TYPICAL)**

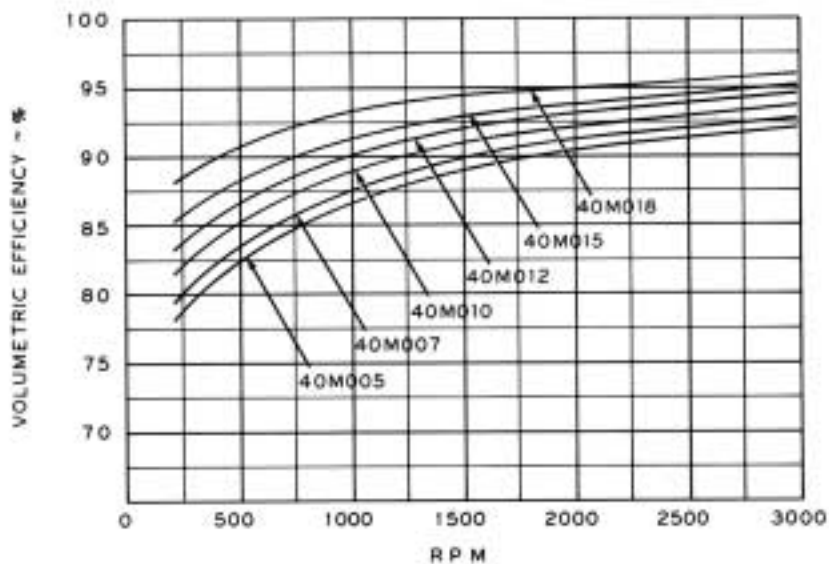

(FOR SPECIFIC PERFORMANCE DATA,  
CONTACT CROSS ENGINEERING)



**CROSS MANUFACTURING, INC.**  
100 Factory Street  
Lewis, Kansas 67552  
Phone: 620/324-5525 Fax -5737