

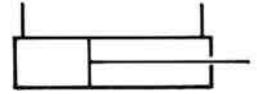

HYDRAULIC CYLINDERS

TIE ROD CYLINDERS
DB SERIES
Specification Sheet



The CROSS series DB tie rod type cylinders provide long life and reliable operation due to high quality materials and workmanship plus the many design features included in this cylinder design. An infinite number of stroke sizes are available as well as many standard and optional features.

GENERAL SPECIFICATIONS

Rated working pressure (max. relief valve setting at full flow) 2500 psi (172 bar)
(See pin recommendations page 3)

Maximum shock and surge pressure 4000 psi (276 bar)

Bore diameters

2.00	2.50	3.00	3.50	4.00	5.00	inches
51	64	76	89	102	127	mm

MATERIAL SPECIFICATIONS

Cylinder barrels ST52.3 steel alloy

Pistons High tensile strength gray iron or aluminum alloy

Rods Induction hardened C1045 steel alloy*

Base castings and rod clevises Ductile iron

Cylinder heads High tensile strength gray iron

Seals 70 durometer Buna N piston o-rings with Polyurethane back-ups

Double lipped Polyurethane u-cup rod seal

*Rods over 3/4" diameter, strokes up to 65"

STANDARD FEATURES

- Cylinder barrels are skived burnished precision finished to provide long seal life
- Rods are hardened, chrome plated and polished for long wear life and for protection from external damage and corrosion
- Rod wipers clean dirt and foreign matter from rod to insure long seal life
- High tensile strength tie rods with rolled threads for durability
- NPTF dryseal pipe thread ports in line with pins
- Double ported base allows connections to be made at 90° to pins

OPTIONAL FEATURES AVAILABLE

- SAE straight thread o-ring ports
- Pineye or single lug rod end mountings
- Hardened steel pins and bushings
- Breather plugs



DIMENSIONAL DATA in inches and (millimeters)

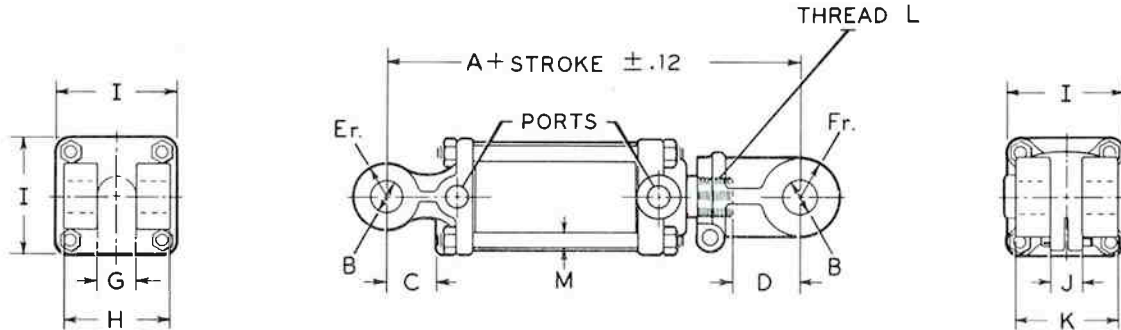

ALL DIMENSIONS ARE NOMINAL and ARE FOR STANDARD CONFIGURATIONS

BORE DIA.	A	B	C	D	Er.	Fr.	G	H	I	J	K	L	M
2.00 (51)	10.25 (260)	1.015 (25.8)	1.625 (41.3)	2.125 (53.9)	.875 (22.2)	1.000 (25.4)	1.125 (28.6)	2.500 (63.5)	2.875 (73.0)	1.125 (28.6)	2.625 (66.7)	1 ¹ / ₁₆ -12	.375 (9.5)
2.50 (64)	10.25 (260)	1.015 (25.8)	1.625 (41.3)	2.125 (53.9)	1.000 (25.4)	1.000 (25.4)	1.125 (28.6)	2.625 (66.7)	3.250 (82.6)	1.125 (28.6)	2.625 (66.7)	1 ¹ / ₁₆ -12	.375 (9.5)
3.00 (76)	10.25 (260)	1.015 (25.8)	1.625 (41.3)	2.125 (53.9)	1.000 (25.4)	1.000 (25.4)	1.125 (28.6)	2.625 (66.7)	3.750 (95.3)	1.125 (28.6)	2.625 (66.7)	1 ¹ / ₄ -12	.500 (12.7)
3.50 (89)	10.25 (260)	1.015 (25.8)	1.625 (41.3)	2.125 (53.9)	1.000 (25.4)	1.250 (31.8)	1.250 (31.8)	2.750 (69.8)	4.250 (107.9)	1.250 (31.8)	2.750 (69.8)	1 ¹ / ₄ -12	.562 (14.3)
4.00 (102)	10.62 (270)	1.015 (25.8)	2.000 (50.8)	2.125 (53.9)	1.125 (28.6)	1.250 (31.8)	1.250 (31.8)	2.875 (73.0)	5.000 (127)	1.250 (31.8)	2.750 (69.8)	1 ¹ / ₄ -12	.625 (15.9)
5.00 (127)	12.25 (311)	1.015 (25.8)	2.312 (58.7)	2.125 (53.9)	1.500 (38.1)	1.250 (31.8)	1.375 (34.9)	3.500 (88.9)	6.000 (152.4)	1.250 (31.8)	2.750 (69.8)	*	.750 (19.0)

*1¹/₄-12 for cylinders in distributor program.

OPTIONAL ROD END MOUNTINGS

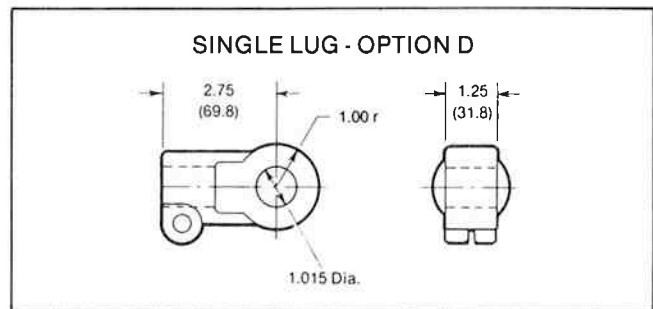
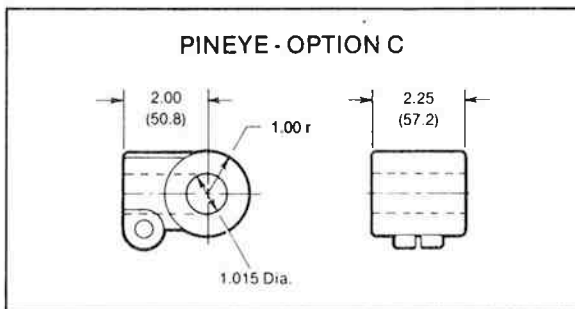

These rod end mountings are optionally available on the 2", 2¹/₂", 3", 3¹/₂" and 4" diameter bore size cylinders only. (Standard mounting clevis will be supplied unless otherwise specified.)



HYDRAULIC CYLINDERS

**TIE ROD CYLINDERS
DB SERIES
Specification Sheet**

CYLINDER PORTS AND RODS

BORE DIA.	SIZE & TYPE PORTS		STANDARD RODS*		OPTIONAL RODS	
	STANDARD	OPTIONAL	DIA.	MAX. STROKE**	DIA.	MAX. STROKE**
2.00 (51)	3/8 NPTF	9/16-18 SAE 1/4 NPTF	1.062 (26.97)	19" (483)	1.125 (28.6)	22" (559)
2.50 (64)	3/8 NPTF	9/16-18 SAE 1/4 NPTF	1.062 (26.97)	14" (356)	1.25 (25.4)	21" (533)
3.00 (76)	1/2 NPTF	3/4-16 SAE 3/8 NPTF	1.250 (31.8)	17" (432)	1.500 (38.1)	27" (686)
3.50 (89)	1/2 NPTF	3/4-16 SAE 3/8 NPTF	1.250 (31.8)	14" (356)	1.500 (38.1)	22" (559)
4.00 (102)	1/2 NPTF	3/4-16 SAE 3/8 NPTF	1.500 (38.1)	19" (483)	1.250 (31.8) 2.000 (50.8)	11" (279) 38" (965)
5.00 (127)	1/2 NPTF	3/4-16 SAE 3/8 NPTF	2.000 (50.8)	28" (711)	1.500 (38.1)	13" (330)

*Consult CROSS Full Line catalog for rod sizes applicable to distributor program.

**At 2500 psi rated operating pressure. Longer strokes are possible at reduced pressures. Additionally, smaller diameter rods can be provided for usage at lower pressures or shorter length strokes. Consult CROSS Sales Dept. for maximum stroke at given pressures. For extended cylinder lengths of over 30" (762 mm), 1" (25.4 mm) of stop tubing should be used for each additional 10" (254 mm) of stroke. Stroke limitation applies to compressive loading only.

CLEVIS PINS

BORE DIA.		STANDARD PINS				OPTIONAL PINS			
		DIA. / MAT'L		MAX. PRESS.		DIA. / MAT'L		MAX. PRESS.	
INCHES	mm	INCHES	mm	PSI	BAR	INCHES	mm	PSI	BAR
2.00	(51)	1.00	(25.4)	2500	(172)	NONE			
		STEEL							
2.50	(64)	1.00	(25.4)	2500	(172)	NONE			
		STEEL							
3.00	(76)	1.00	(25.4)	2500	(172)	NONE			
		STEEL							
3.50	(89)	1.00	(25.4)	2000	(138)	1.00	(25.4)	2500	(172)
		STEEL				HARDENED STEEL			
4.00	(102)	1.00	(25.4)	1500	(103)	1.00	(25.4)	2500	(172)
		STEEL				HARDENED STEEL			
5.00	(127)	1.00	(25.4)	1000	(69)	1.25	(31.8)	2500	(172)
		STEEL				HARDENED STEEL			

Hardened steel bushings are provided with hardened steel pins.



ORDERING INFORMATION

(Standard configurations will be supplied unless specified)

SERIES	BORE DIA. INCH x 100	STROKE INCH x 100	ROD DIA. INCH x 100	PORT SIZE and TYPE	END MOUNTING	CLEVIS PIN	OTHER
DB	200 250 300 350 400 500	AS REQUIRED	106 125 150 200	C ⁹ / ₁₆ -18 SAE D ³ / ₄ -16 SAE N ¹ / ₄ NPTF P ³ / ₈ NPTF R ¹ / ₂ NPTF S ³ / ₄ NPTF	C CLEVIS (Standard) P PINEYE S SINGLE LUG	A 1.00 STL. B 1.00 HARD C 1.25 HARD D NONE (1.015 hole) E NONE (1.265 hole)	O NONE X SPECIFY

EXAMPLE: DB250-1500-106CCAO is a standard 2 1/2" bore diameter DB Series cylinder with 15" stroke, 1.062" dia.rod, 9/16 - 18 ports, standard clevis end mountings with 1" dia. steel clevis pins.

ASAE STANDARD CYLINDERS

The DB-ASAE cylinders are designed for use where ASAE 8" and 16" stroke cylinders are required. To obtain an ASAE cylinder, the following model number may be used. Characteristics of these cylinders are shown for reference purposes as there are no options available. (Contact CROSS Sales Department for DB-ASAE cylinders with SAE straight thread o-ring ports).

MODEL NUMBER	BORE DIA. INCHES	STROKE INCHES	ROD DIA. INCHES	CLOSED CENTER DIM INCHES	PORT SIZE & TYPE	CLEVIS PIN	WEIGHT LBS.
208DB-ASAE	2	8	1 1/16	20 1/4	3/8" NPTF	1"	18
2508DB-ASAE	2 1/2	8	1 1/16	20 1/4	3/8" NPTF	1"	20
308DB-ASAE	3	8	1 1/4	20 1/4	1/2" NPTF	1"	24
3508DB-ASAE	3 1/2	8	1 1/4	20 1/4	1/2" NPTF	1"	30
408DB-ASAE	4	8	1 1/4	20 1/4	1/2" NPTF	1"	37
508DB-ASAE	5	8	1 1/2	20 1/4	1/2" NPTF	1" *	66
316DB-ASAE	3	16	1 1/4	31 1/2	1/2" NPTF	1 1/4"	35
3516DB-ASAE	3 1/2	16	1 1/2	31 1/2	1/2" NPTF	1 1/4"	51
416DB-ASAE	4	16	2	31 1/2	1/2" NPTF	1 1/4"	65
516DB-ASAE	5	16	2	31 1/2	1/2" NPTF	1 1/4"	88

*Limited to 1500 psi maximum operating pressure



CROSS MANUFACTURING, INC.
100 Factory Street
Lewis, Kansas 67552
Phone 620/324-5525; FAX 620/324-5737; e-mail: info@crossmfg.com