

white drive products



RS

SERIES HYDRAULIC MOTORS

RS

OVERVIEW

RS Series motors are the most economical model in the White Drive Products product line, but are not low-tech. Unlike competitive products using power robbing, two-piece rotor set designs with sliding contact points, RS Series motors utilize the patented Roller Stator® design. Seven precision rollers for the contact points reduce friction, providing more power and longer life for your application. Each output shaft is custom ground to maintain exact tolerances between the housing and shaft, producing high volumetric efficiencies. Industry standard mounting flanges and output shafts allow the RS Series motors to interchange with competitive designs.

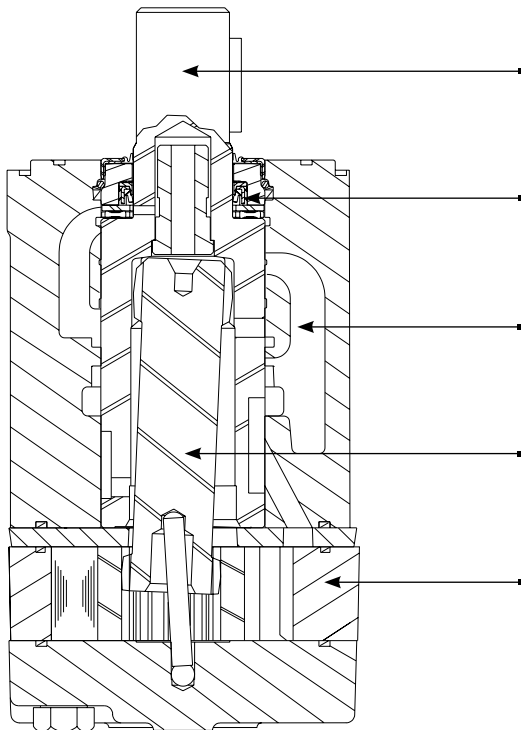

KEY FEATURES

Match Ground Shaft is matched to housing bore to maintain highest volumetric efficiencies.

High Pressure Shaft Seal offers superior seal life and performance and eliminates the need for case drain.

Pressure Fed Bearing surface receives positive flow of clean, cool oil.

Heavy-Duty Drive Link receives full flow lubrication to provide long life.

Roller Stator® Motor Design increases efficiency and life by using roller contact versus solid, sliding contact design.

SPECIFICATIONS

Intermittent Ratings - 10% of Operation Peak Ratings - 1% of Operation

CODE	Displacement cc [in ³ /rev]	Max. Speed rpm		Max. Flow lpm [gpm]		Max. Torque Nm [lb-in]		Max. Pressure bar [psi]		
		cont.	inter.	cont.	inter.	cont.	inter.	cont.	inter.	peak
050	52 [3.2]	400	490	23 [6]	38 [10]	82 [730]	95 [840]	121 [1750]	138 [2000]	155 [2250]
080	76 [4.6]	460	540	38 [10]	45 [12]	121 [1070]	138 [1230]	121 [1750]	138 [2000]	155 [2250]
090	89 [5.4]	420	580	38 [10]	45 [12]	147 [1300]	167 [1480]	121 [1750]	138 [2000]	155 [2250]
100	103 [6.3]	510	570	53 [14]	61 [16]	169 [1500]	195 [1725]	121 [1750]	138 [2000]	155 [2250]
110	111 [6.8]	460	600	53 [14]	68 [18]	184 [1630]	214 [1900]	121 [1750]	138 [2000]	155 [2250]
125	127 [7.7]	410	530	53 [14]	68 [18]	181 [1600]	208 [1850]	103 [1500]	121 [1750]	155 [2250]
160	164 [10.0]	370	460	61 [16]	76 [20]	222 [1970]	265 [2350]	103 [1500]	121 [1750]	155 [2250]
200	205 [12.5]	300	370	61 [16]	76 [20]	297 [2640]	345 [3050]	103 [1500]	121 [1750]	155 [2250]
250	254 [15.5]	300	360	76 [20]	91 [24]	287 [2540]	344 [3040]	86 [1250]	104 [1500]	121 [1750]
300	293 [17.9]	300	310	76 [20]	91 [24]	277 [2460]	350 [3100]	69 [1000]	86 [1250]	103 [1500]
400	409 [24.9]	190	220	76 [20]	91 [24]	377 [3350]	463 [4100]	69 [1000]	86 [1250]	103 [1500]



050

Pressure - bars [psi]						Max. Cont.	Max. Inter.
17 [250]	35 [500]	52 [750]	69 [1000]	86 [1250]	104 [1500]	121 [1750]	138 [2000]

52 cc [3.2 in³/rev.]

Torque - Nm [lb-in], Speed rpm Intermittent Ratings - 10% of Operation

Max. Cont. Flow - lpm [gpm]	2 [0.5]	10 [89] 35	15 [133] 33	25 [223] 26	33 [290] 24	42 [375] 24	49 [435] 12			37	
	4 [1]	10 [92] 69	18 [163] 68	29 [253] 68	39 [348] 67	49 [438] 54	59 [523] 49	55 [483] 4		73	
	8 [2]	10 [90] 142	20 [181] 140	31 [274] 138	41 [366] 136	52 [464] 127	63 [556] 103	74 [653] 78	78 [690] 34	145	
	15 [4]	10 [85] 288	17 [154] 285	28 [251] 283	40 [355] 282	53 [465] 275	65 [572] 258	76 [669] 227	86 [764] 193	289	
	23 [6]		19 [168] 433	27 [243] 432	39 [342] 430	50 [445] 429	62 [549] 408	74 [656] 380	85 [755] 346	434	
	30 [8]		17 [148] 576	27 [243] 574	36 [318] 570	47 [417] 568	59 [526] 554	71 [631] 535		578	
	38 [10]		13 [119] 718	25 [218] 711	35 [307] 701	48 [429] 700	56 [499] 689	67 [593] 682		722	
	Max. Inter.										

Overall Efficiency - 70 - 100% 40 - 69% 0 - 39%

Theoretical Torque - Nm [lb-in]

14 [127]	29 [255]	43 [382]	58 [510]	72 [637]	86 [764]	101 [892]	115 [1019]
----------	----------	----------	----------	----------	----------	-----------	------------

Displacement tested at 54°C [129°F] with an oil viscosity of 46cSt [213 SUS]

080

Pressure - bars [psi]						Max. Cont.	Max. Inter.
17 [250]	35 [500]	52 [750]	69 [1000]	86 [1250]	104 [1500]	121 [1750]	138 [2000]

76 cc [4.6 in³/rev.]

Torque - Nm [lb-in], Speed rpm Intermittent Ratings - 10% of Operation

Max. Cont. Flow - lpm [gpm]	2 [0.5]	12 [107] 25	26 [227] 21	39 [341] 20	51 [456] 9	58 [509] 5				26	
	4 [1]	12 [110] 50	29 [252] 50	43 [381] 42	59 [522] 35	75 [661] 34	81 [720] 11			51	
	8 [2]	14 [122] 100	29 [260] 99	46 [405] 99	63 [560] 93	80 [707] 82	96 [848] 73	110 [973] 48	115 [1016] 20	101	
	15 [4]		30 [263] 200	47 [416] 196	65 [574] 193	82 [726] 184	98 [871] 168	118 [1046] 150	134 [1184] 121	201	
	23 [6]		28 [252] 301	46 [403] 297	64 [562] 293	82 [721] 287	98 [869] 271	115 [1020] 252	134 [1183] 218	302	
	30 [8]		25 [221] 400	43 [379] 399	63 [555] 393	79 [703] 390	97 [860] 375	115 [1014] 355	132 [1172] 330	402	
	38 [10]			39 [341] 502	57 [502] 500	74 [657] 498	93 [819] 496	111 [980] 472	128 [1135] 443	503	
	45 [12]			35 [314] 602	50 [446] 600	71 [625] 599	92 [816] 598	105 [932] 580		603	
	Max. Inter.										

Overall Efficiency - 70 - 100% 40 - 69% 0 - 39%

Theoretical Torque - Nm [lb-in]

21 [183]	41 [366]	62 [549]	83 [732]	103 [916]	124 [1099]	145 [1282]	166 [1465]
----------	----------	----------	----------	-----------	------------	------------	------------

Displacement tested at 54°C [129°F] with an oil viscosity of 46cSt [213 SUS]

090

Pressure - bars [psi]						Max. Cont.	Max. Inter.
17 [250]	35 [500]	52 [750]	69 [1000]	86 [1250]	104 [1500]	121 [1750]	138 [2000]

89 cc [5.4 in³/rev.]

Torque - Nm [lb-in], Speed rpm Intermittent Ratings - 10% of Operation

Max. Cont. Flow - lpm [gpm]	2 [0.5]	23 [206] 20	43 [376] 19	63 [559] 17	84 [743] 14	98 [864] 10	105 [933] 1			22	
	4 [1]		43 [383] 41	64 [566] 40	86 [760] 37	108 [953] 32	127 [1123] 25	138 [1225] 12		43	
	8 [2]		44 [388] 85	63 [561] 84	83 [739] 81	106 [937] 75	127 [1121] 66	151 [1336] 51	169 [1495] 31	86	
	15 [4]			61 [538] 169	85 [754] 166	104 [920] 159	128 [1134] 149	148 [1309] 133	168 [1484] 115	172	
	23 [6]				81 [720] 251	102 [902] 244	125 [1105] 229	144 [1275] 213	164 [1450] 191	257	
	30 [8]				78 [686] 338	98 [867] 330	122 [1080] 318	141 [1251] 300	164 [1448] 278	343	
	38 [10]					93 [824] 417	113 [1004] 406	137 [1210] 386	161 [1422] 365	428	
	45 [12]					81 [715] 504	87 [766] 491	113 [998] 478		514	
	Max. Inter.										

Overall Efficiency - 70 - 100% 40 - 69% 0 - 39%

Theoretical Torque - Nm [lb-in]

24 [215]	49 [430]	73 [645]	97 [860]	121 [1075]	146 [1290]	170 [1505]	194 [1720]
----------	----------	----------	----------	------------	------------	------------	------------

Displacement tested at 54°C [129°F] with an oil viscosity of 46cSt [213 SUS]



PERFORMANCE

100

Pressure - bars [psi]						Max. Cont.	Max. Inter.
17 [250]	35 [500]	52 [750]	69 [1000]	86 [1250]	104 [1500]	121 [1750]	138 [2000]

103 cc [6.3 in³/rev.]

Flow - lpm [gpm]	Torque - Nm [lb-in], Speed rpm								Intermittent Ratings - 10% of Operation	
	25 [221] 17	52 [461] 16	76 [676] 15	98 [870] 12	115 [1020] 7					19
4 [1]	26 [233] 36	51 [449] 36	77 [680] 34	103 [914] 32	126 [1116] 28	146 [1295] 23	166 [1473] 13	151 [1336] 1		37
8 [2]		49 [433] 72	77 [682] 71	101 [893] 69	125 [1108] 65	150 [1331] 59	174 [1538] 50	199 [1758] 37		74
15 [4]			73 [648] 143	99 [873] 135	123 [1088] 124	146 [1291] 118	170 [1504] 94	195 [1721] 75		147
23 [6]			69 [606] 219	94 [830] 213	120 [1062] 203	145 [1279] 190	165 [1463] 177	194 [1717] 154		220
30 [8]				89 [789] 288	113 [999] 278	142 [1254] 264	161 [1429] 249	187 [1658] 230		294
38 [10]				78 [693] 363	102 [905] 353	127 [1124] 341	156 [1380] 322	182 [1612] 301		367
45 [12]					85 [755] 433	119 [1049] 421	147 [1299] 405	172 [1526] 384		440
53 [14]					84 [746] 507	118 [1040] 497	135 [1198] 484	141 [1250] 465		514
61 [16]						108 [957] 574	135 [1197] 566			587

Overall Efficiency - 70 - 100% 40 - 69% 0 - 39%

Theoretical Torque - Nm [lb-in]							
28 [251]	57 [502]	85 [752]	113 [1003]	142 [1254]	170 [1505]	198 [1756]	227 [2006]

Displacement tested at 54°C [129°F] with an oil viscosity of 46cSt [213 SUS]

110

Pressure - bars [psi]						Max. Cont.	Max. Inter.
17 [250]	35 [500]	52 [750]	69 [1000]	86 [1250]	104 [1500]	121 [1750]	138 [2000]

111 cc [6.8 in³/rev.]

Flow - lpm [gpm]	Torque - Nm [lb-in], Speed rpm								Intermittent Ratings - 10% of Operation	
	26 [227] 16	54 [481] 14	78 [689] 11	100 [888] 7	109 [961] 1					17
4 [1]	29 [253] 33	55 [489] 32	83 [733] 30	110 [974] 26	134 [1183] 20	153 [1356] 10				34
8 [2]		57 [503] 67	82 [727] 64	110 [969] 60	135 [1199] 52	162 [1431] 40	184 [1631] 20	180 [1590] 1		68
15 [4]		54 [479] 135	80 [706] 133	107 [951] 128	134 [1190] 120	162 [1437] 104	186 [1643] 88	216 [1911] 58		136
23 [6]			76 [669] 201	106 [934] 193	129 [1144] 183	153 [1357] 165	185 [1636] 141	206 [1826] 114		204
30 [8]			70 [621] 271	97 [862] 267	123 [1092] 256	151 [1336] 242	177 [1569] 220	202 [1788] 196		272
38 [10]				88 [779] 335	116 [1025] 324	146 [1294] 307	170 [1505] 289	201 [1783] 254		340
45 [12]				86 [764] 405	109 [963] 396	139 [1226] 376	168 [1482] 351	190 [1683] 330		408
53 [14]					102 [901] 463	129 [1142] 449	156 [1378] 427	184 [1626] 406		476
61 [16]					95 [844] 535	121 [1075] 523	147 [1297] 505			544
68 [18]						111 [984] 595	136 [1205] 579			612

Overall Efficiency - 70 - 100% 40 - 69% 0 - 39%

Theoretical Torque - Nm [lb-in]							
31 [271]	61 [541]	92 [812]	122 [1083]	153 [1354]	184 [1624]	214 [1895]	245 [2166]

Displacement tested at 54°C [129°F] with an oil viscosity of 46cSt [213 SUS]



125

Pressure - bars [psi]					Max. Cont.	Max. Inter.
17 [250]	35 [500]	52 [750]	69 [1000]	86 [1250]	104 [1500]	121 [1750]

127 cc [7.7 in³/rev.]

Torque - Nm [lb-in], **Speed rpm** Intermittent Ratings - 10% of Operation

Flow - lpm [gpm]	2 [0.5]	29 [225] 14	60 [534] 12	86 [758] 10	112 [990] 7	129 [1145] 2		15	Theoretical rpm	
	4 [1]	28 [251] 29	62 [545] 28	93 [819] 26	121 [1073] 23	149 [1319] 18	173 [1531] 10	176 [1559] 1		30
	8 [2]		61 [537] 58	92 [816] 57	125 [1103] 54	153 [1356] 49	182 [1609] 41	210 [1856] 29		60
	15 [4]		61 [538] 118	90 [797] 115	123 [1084] 108	151 [1338] 99	181 [1602] 84	210 [1860] 65		120
	23 [6]			87 [771] 177	117 [1032] 168	149 [1321] 158	177 [1566] 145	208 [1838] 123		180
	30 [8]			82 [722] 234	112 [987] 229	142 [1257] 215	175 [1548] 203	201 [1781] 186		240
	38 [10]				105 [927] 290	137 [1214] 277	167 [1474] 263	194 [1720] 244		300
	45 [12]				97 [859] 349	120 [1066] 339	157 [1386] 322	183 [1622] 306		360
	53 [14]				89 [787] 409	119 [1051] 385	146 [1295] 376	174 [1536] 367		420
	61 [16]					99 [879] 471	131 [1163] 459			480
	68 [18]					100 [885] 528	119 [1053] 512			540

Overall Efficiency - 70 - 100% 40 - 69% 0 - 39%

Theoretical Torque - Nm [lb-in]

35 [307]	69 [613]	104 [920]	139 [1226]	173 [1533]	208 [1839]	242 [2146]
----------	----------	-----------	------------	------------	------------	------------

Displacement tested at 54°C [129°F] with an oil viscosity of 46cSt [213 SUS]

160

Pressure - bars [psi]					Max. Cont.	Max. Inter.
17 [250]	35 [500]	52 [750]	69 [1000]	86 [1250]	104 [1500]	121 [1750]

164 cc [10.0 in³/rev.]

Torque - Nm [lb-in], **Speed rpm** Intermittent Ratings - 10% of Operation

Flow - lpm [gpm]	2 [0.5]	32 [281] 11	71 [630] 10	103 [908] 8	141 [1247] 6	167 [1481] 2		12	Theoretical rpm	
	4 [1]	35 [308] 22	76 [677] 21	111 [983] 20	141 [1245] 20	182 [1615] 16	211 [1867] 11	234 [2070] 3		24
	8 [2]	36 [320] 45	78 [694] 45	116 [1023] 44	159 [1403] 42	193 [1707] 39	223 [1974] 34	257 [2279] 27		47
	15 [4]		72 [633] 91	114 [1007] 90	155 [1375] 86	190 [1679] 80	226 [1998] 71	262 [2319] 56		93
	23 [6]		69 [608] 138	109 [961] 137	149 [1318] 132	188 [1667] 125	224 [1979] 114	267 [2359] 101		139
	30 [8]		65 [573] 184	104 [921] 183	139 [1233] 180	181 [1597] 171	219 [1941] 161	258 [2284] 148		185
	38 [10]			95 [837] 230	134 [1184] 229	173 [1531] 221	212 [1874] 211	251 [2220] 197		231
	45 [12]			83 [736] 276	124 [1095] 275	162 [1432] 270	203 [1796] 259	241 [2133] 245		278
	53 [14]			73 [643] 322	114 [1010] 321	154 [1366] 320	194 [1714] 310	231 [2045] 295		324
	61 [16]				102 [901] 369	142 [1255] 368	179 [1585] 362	219 [1936] 345		370
	68 [18]				93 [824] 415	127 [1121] 414	164 [1447] 410			416
	76 [20]					111 [980] 460	152 [1348] 460			462

Overall Efficiency - 70 - 100% 40 - 69% 0 - 39%

Theoretical Torque - Nm [lb-in]

45 [398]	90 [796]	135 [1194]	180 [1592]	225 [1990]	270 [2389]	315 [2787]
----------	----------	------------	------------	------------	------------	------------

Displacement tested at 54°C [129°F] with an oil viscosity of 46cSt [213 SUS]



200

Pressure - bars [psi]					Max. Cont.	Max. Inter.
17 [250]	35 [500]	52 [750]	69 [1000]	86 [1250]	104 [1500]	121 [1750]

205 cc [12.5 in³/rev.]

Flow - lpm [gpm]	Torque - Nm [lb-in], Speed rpm							Intermittent Ratings - 10% of Operation		
	2 [0.5]	4 [1]	8 [2]	15 [4]	23 [6]	30 [8]	38 [10]	45 [12]	53 [14]	Theoretical rpm
	47 [414] 8	96 [846] 7	141 [1250] 6	183 [1621] 5	224 [1983] 3					10
	49 [432] 17	98 [865] 17	154 [1360] 15	196 [1732] 14	241 [2136] 11	284 [2517] 9	318 [2811] 5			19
	47 [416] 36	105 [927] 36	157 [1386] 34	204 [1809] 31	245 [2166] 29	299 [2642] 23	341 [3019] 17			37
	43 [380] 73	96 [849] 73	152 [1349] 72	203 [1798] 68	249 [2204] 65	298 [2641] 60	350 [3094] 52			74
		90 [795] 110	149 [1322] 110	194 [1721] 106	249 [2207] 103	298 [2634] 96	340 [3007] 90			111
		83 [734] 147	139 [1228] 146	192 [1697] 144	238 [2102] 142	296 [2621] 133	339 [2997] 126			148
		75 [666] 184	128 [1134] 183	175 [1546] 183	227 [2013] 181	280 [2482] 172	329 [2910] 166			185
			116 [1026] 221	167 [1475] 220	217 [1924] 218	262 [2322] 214	316 [2795] 205			222
			97 [862] 258	153 [1358] 257	205 [1811] 256	251 [2218] 252	300 [2656] 249			259
			85 [752] 295	137 [1212] 295	191 [1687] 294	240 [2127] 291	292 [2583] 284			296
				122 [1079] 332	174 [1541] 331	224 [1981] 330				333
				104 [924] 369	154 [1366] 368	207 [1833] 367				370

Overall Efficiency - 70 - 100% 40 - 69% 0 - 39%

Theoretical Torque - Nm [lb-in]

56 [498]	112 [995]	169 [1493]	225 [1990]	281 [2488]	337 [2986]	394 [3483]
----------	-----------	------------	------------	------------	------------	------------

Displacement tested at 54°C [129°F] with an oil viscosity of 46cSt [213 SUS]

250

Pressure - bars [psi]					Max. Cont.	Max. Inter.
17 [250]	35 [500]	52 [750]	69 [1000]	86 [1250]	104 [1500]	

254 cc [15.5 in³/rev.]

Flow - lpm [gpm]	Torque - Nm [lb-in], Speed rpm							Intermittent Ratings - 10% of Operation		
	2 [0.5]	4 [1]	8 [2]	15 [4]	23 [6]	30 [8]	38 [10]	45 [12]	53 [14]	Theoretical rpm
	52 [457] 6	104 [919] 4	150 [1327] 2							8
	52 [458] 14	112 [988] 12	168 [1491] 10	222 [1966] 7	267 [2361] 4	300 [2658] 1				15
	55 [490] 29	115 [1018] 27	171 [1512] 24	231 [2041] 20	288 [2547] 14	323 [2856] 9				30
	49 [437] 59	116 [1028] 58	171 [1517] 56	233 [2064] 51	288 [2551] 44	344 [3040] 34				60
	45 [398] 88	105 [930] 88	163 [1440] 87	222 [1966] 82	284 [2512] 76	345 [3051] 62				90
		90 [795] 118	147 [1305] 117	186 [1649] 115	268 [2372] 106	330 [2918] 96				120
		76 [676] 148	142 [1253] 147	196 [1738] 146	256 [2263] 140	311 [2754] 133				150
		25 [225] 178	124 [1098] 177	186 [1642] 176	234 [2071] 173	282 [2499] 163				179
			89 [784] 208	157 [1386] 206	222 [1962] 204	278 [2460] 194				209
			82 [722] 237	142 [1256] 236	202 [1786] 234	261 [2306] 228				239
				124 [1096] 266	183 [1618] 264	240 [2126] 259				269
				95 [842] 297	157 [1387] 295	217 [1919] 293				299
					130 [1147] 327					328
					99 [874] 356					358

Overall Efficiency - 70 - 100% 40 - 69% 0 - 39%

Theoretical Torque - Nm [lb-in]

70 [617]	139 [1234]	209 [1851]	279 [2468]	349 [3085]	418 [3702]
----------	------------	------------	------------	------------	------------

Displacement tested at 54°C [129°F] with an oil viscosity of 46cSt [213 SUS]



300

Pressure - bars [psi]		Max. Cont.		Max. Inter.	
17 [250]	35 [500]	52 [750]	69 [1000]	86 [1250]	

293 cc [17.9 in³/rev.]

Torque - Nm [lb-in], **Speed rpm** **Intermittent Ratings - 10% of Operation**

Flow - lpm [gpm]	2 [0.5]	58 [516] 5	126 [1111] 5	185 [1638] 5			7	Theoretical rpm
	4 [1]	64 [563] 12	124 [1096] 12	189 [1673] 11	263 [2325] 10	329 [2912] 9	13	
	8 [2]	64 [564] 25	133 [1180] 25	199 [1758] 24	268 [2375] 23	343 [3033] 21	26	
	15 [4]	59 [524] 51	135 [1193] 51	200 [1773] 50	269 [2384] 50	355 [3145] 47	52	
	23 [6]	53 [468] 76	126 [1116] 76	195 [1728] 75	278 [2463] 75	350 [3096] 74	78	
	30 [8]		108 [954] 102	186 [1650] 101	251 [2218] 101	339 [3000] 100	104	
	38 [10]		100 [887] 128	170 [1503] 128	241 [2132] 127	319 [2824] 126	130	
	45 [12]		79 [698] 154	156 [1381] 154	220 [1944] 153	301 [2660] 152	155	
	53 [14]		63 [558] 180	136 [1206] 180	201 [1780] 179	284 [2512] 179	181	
	61 [16]			113 [1000] 205	184 [1630] 204	250 [2213] 203	207	
	68 [18]				156 [1382] 231	216 [1915] 230	233	
	76 [20]				119 [1054] 257	190 [1679] 256	259	
	83 [22]				83 [738] 283		284	
	91 [24]						310	

Overall Efficiency - 70 - 100% 40 - 69% 0 - 39%

Theoretical Torque - Nm [lb-in]

81 [713]	161 [1425]	242 [2138]	322 [2850]	403 [3563]
----------	------------	------------	------------	------------

Displacement tested at 54°C [129°F] with an oil viscosity of 46cSt [213 SUS]

400

Pressure - bars [psi]		Max. Cont.		Max. Inter.	
17 [250]	35 [500]	52 [750]	69 [1000]	86 [1250]	

409 cc [24.9 in³/rev.]

Torque - Nm [lb-in], **Speed rpm** **Intermittent Ratings - 10% of Operation**

Flow - lpm [gpm]	2 [0.5]	87 [767] 3	187 [1656] 2				5	Theoretical rpm
	4 [1]	90 [793] 8	180 [1597] 8	274 [2425] 6	369 [3270] 6	446 [3951] 3	10	
	8 [2]	88 [777] 18	175 [1550] 17	286 [2528] 16	374 [3309] 15	466 [4124] 12	19	
	15 [4]	85 [753] 37	177 [1565] 36	287 [2540] 35	382 [3384] 33	469 [4153] 29	38	
	23 [6]	71 [631] 55	169 [1498] 55	280 [2477] 54	370 [3273] 52	466 [4122] 49	56	
	30 [8]	58 [516] 73	158 [1396] 71	257 [2274] 70	352 [3119] 69	441 [3901] 68	75	
	38 [10]		141 [1247] 92	238 [2103] 91	328 [2906] 90	434 [3837] 87	93	
	45 [12]		118 [1042] 110	225 [1989] 109	303 [2682] 108	408 [3613] 107	112	
	53 [14]		89 [792] 129	189 [1670] 128	278 [2463] 126	367 [3251] 124	130	
	61 [16]		59 [520] 147	154 [1359] 146	249 [2204] 144	334 [2954] 143	149	
	68 [18]			116 [1027] 166	219 [1934] 165	320 [2746] 164	167	
	76 [20]			89 [790] 185	188 [1663] 184	264 [2336] 183	186	
	83 [22]				140 [1242] 204		205	
	91 [24]				93 [824] 222		223	

Overall Efficiency - 70 - 100% 40 - 69% 0 - 39%

Theoretical Torque - Nm [lb-in]

112 [991]	224 [1982]	336 [2974]	448 [3965]	560 [4956]
-----------	------------	------------	------------	------------

Displacement tested at 54°C [129°F] with an oil viscosity of 46cSt [213 SUS]



200 & 201 SERIES HOUSINGS (SAE A MOUNTS)

A10 2-Hole 1/2" NPT Aligned Ports

A11 2-Hole 7/8" O-Ring Aligned Ports

A18 2-Hole 1/2" BSP.F Aligned Ports

A68 2-Hole 1/2" BSP.F Aligned Ports*

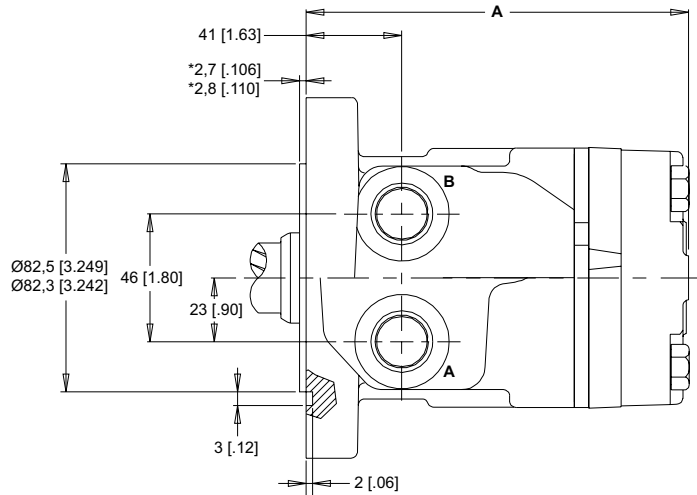
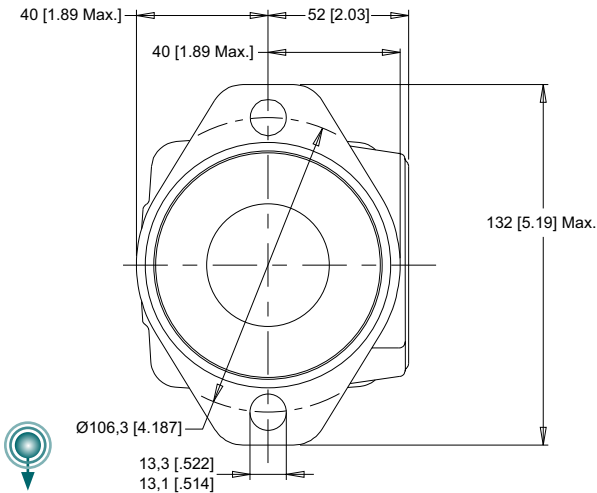

NOTE: Dimension A is found on page 12. * Pilot height is 5,2 [.205] - 5,3 [.210] for the A62, A67, & A68. ** For the A67 the four mounting holes are M8 x 1.25 at same depth.

A12 2-Hole 1/2" BSP.F Offset Ports

A62 2-Hole 1/2" BSP.F Offset Ports*

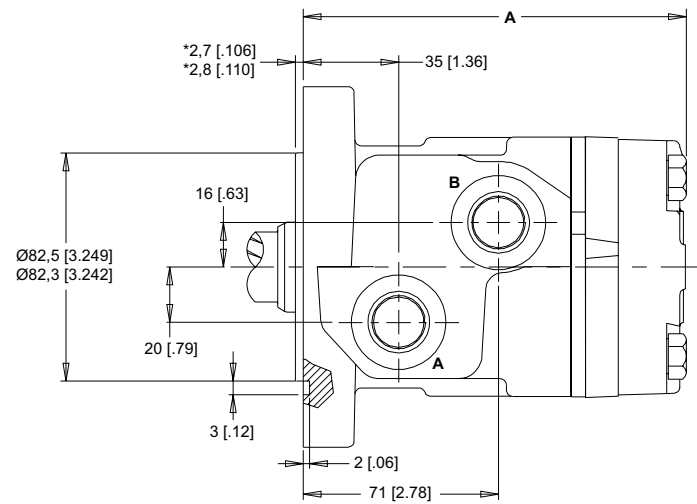
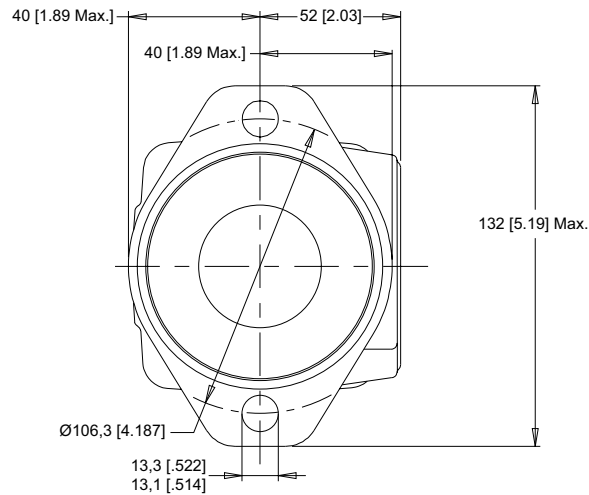

A17 2-Hole 1/2" Manifold Ports

A67 2-Hole 1/2" Manifold Ports*

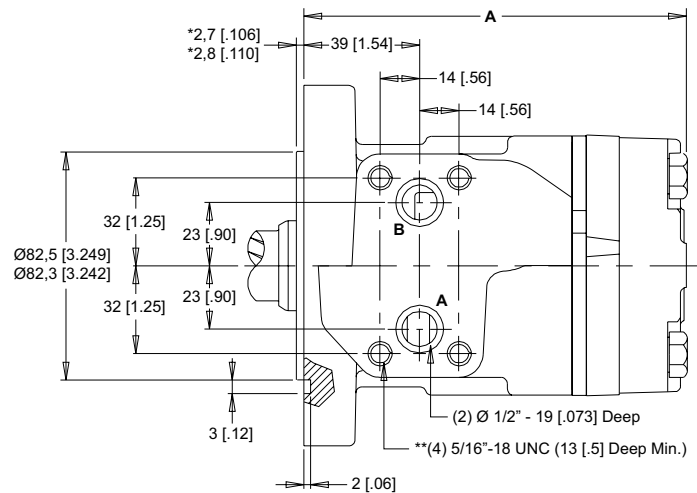
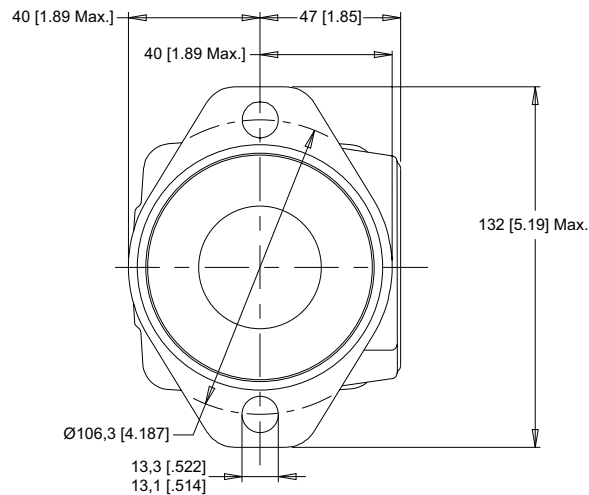



200 & 201 SERIES HOUSINGS (SAE A MOUNTS)

A13 2-Hole 1/2" BSP.F Manifold Ports

A63 2-Hole 1/2" BSP.F Manifold Ports*

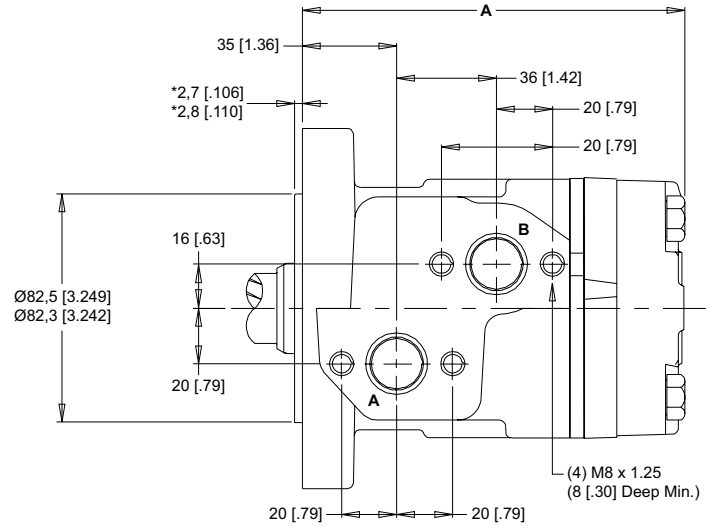
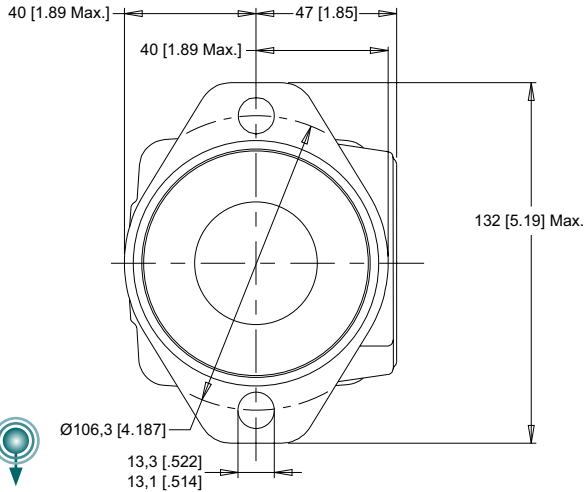

NOTE: Dimension A is found on page 12. * Pilot height is 5,2 [.205] - 5,3 [.210] for the A62, A67, & A68.

A70 2-Hole 1/2" NPT Side Ports

A71 2-Hole 7/8" O-Ring Side Ports

A72 2-Hole 1/2" BSP.F Side Ports

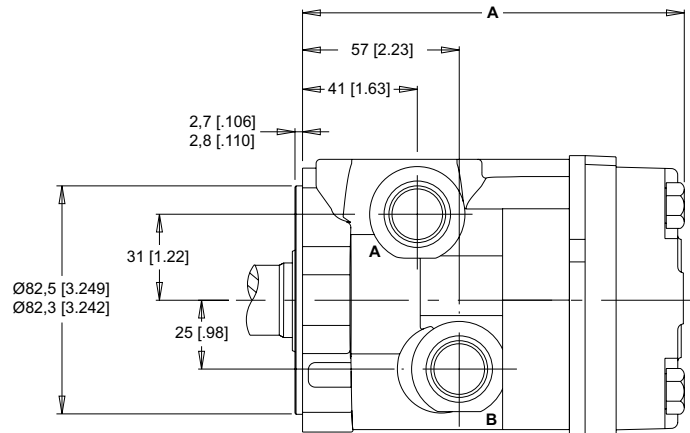
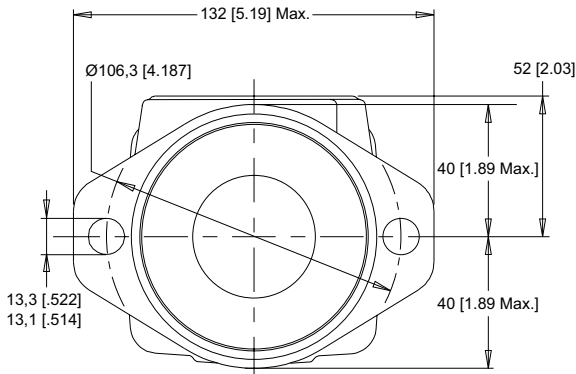

A19 2-Hole 7/8" O-Ring Offset Ports With Valve Cavity

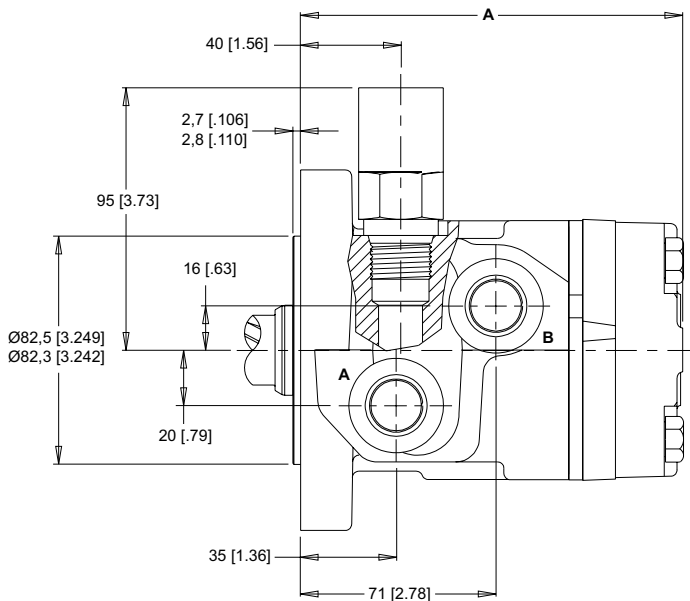
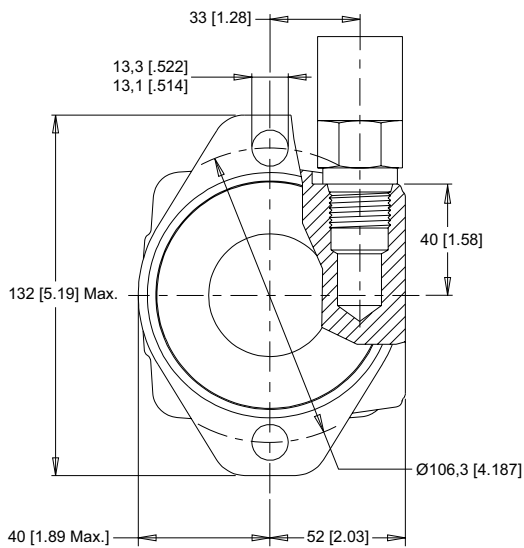



200 & 201 SERIES HOUSINGS (4-HOLE SQUARE MOUNTS)

F30 4-Hole 1/2" NPT Aligned Ports

F31 4-Hole 7/8" O-Ring Aligned Ports

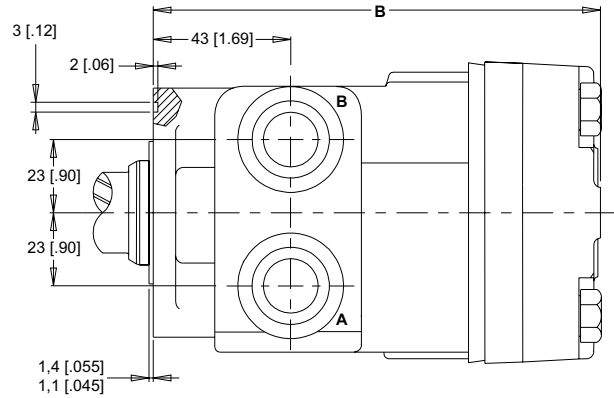
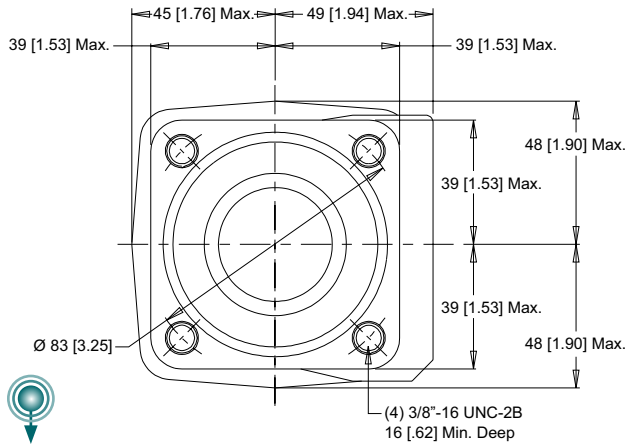

NOTE: Dimension B is found on page 12.

F37 4-Hole Manifold Ports

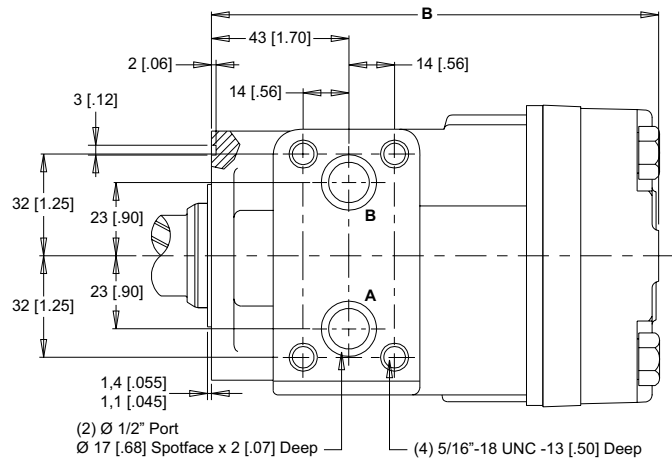
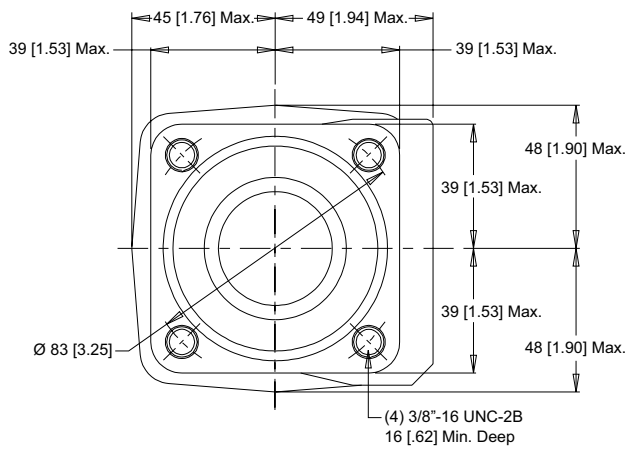

F39 4-Hole 7/8" O-Ring Offset Ports With Valve Cavity

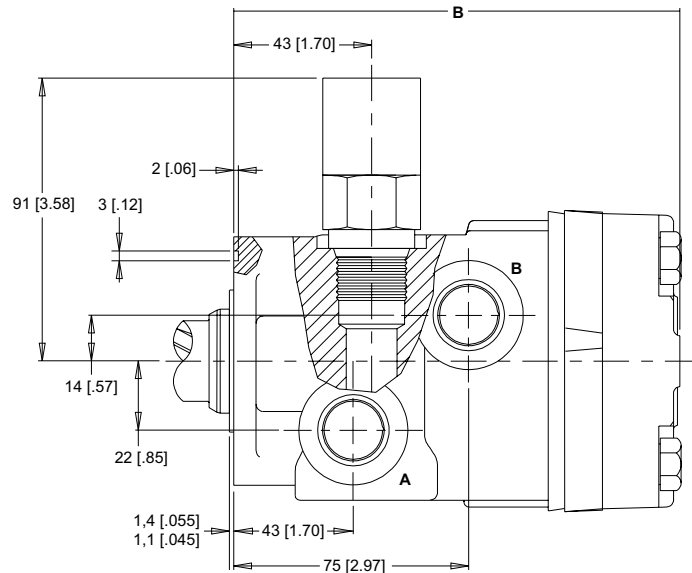
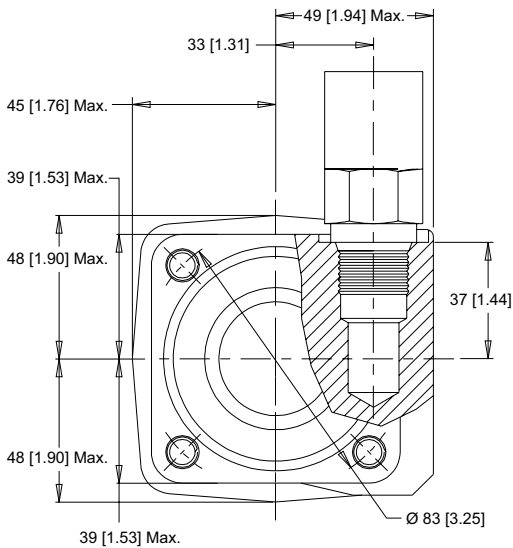



200 & 201 SERIES HOUSINGS (SAE B MOUNTS)

B10 2-Hole 1/2" NPT Aligned Ports

B11 2-Hole 7/8" O-Ring Aligned Ports

B18 2-Hole 1/2" BSP.F Aligned Ports

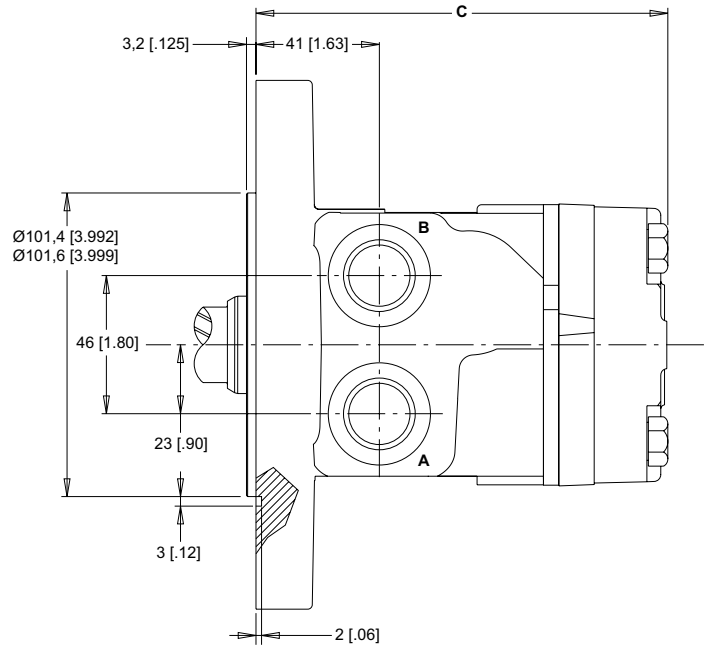
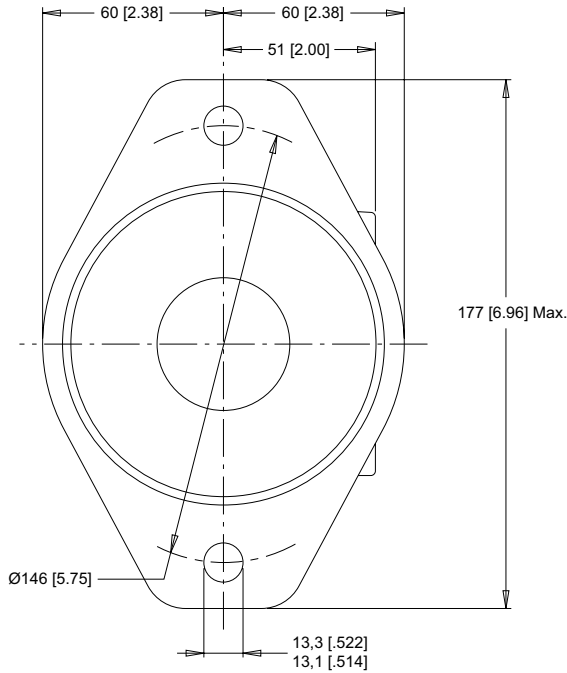

B70 2-Hole 1/2" NPT Side Ports

B71 2-Hole 7/8" O-Ring Side Ports

B72 2-Hole 1/2" BSP.F Side Ports

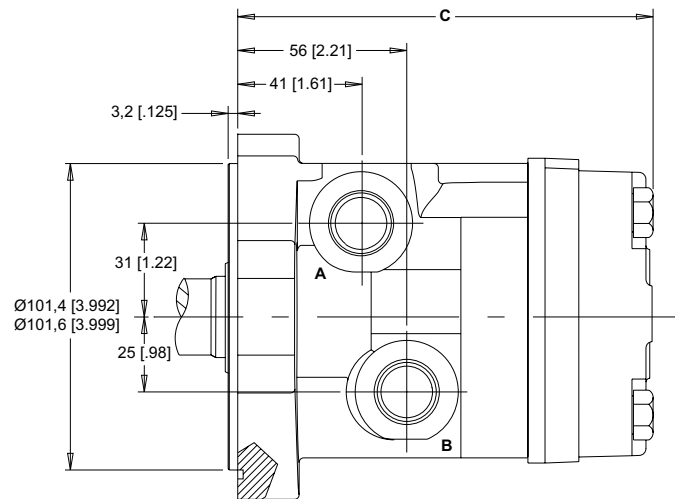
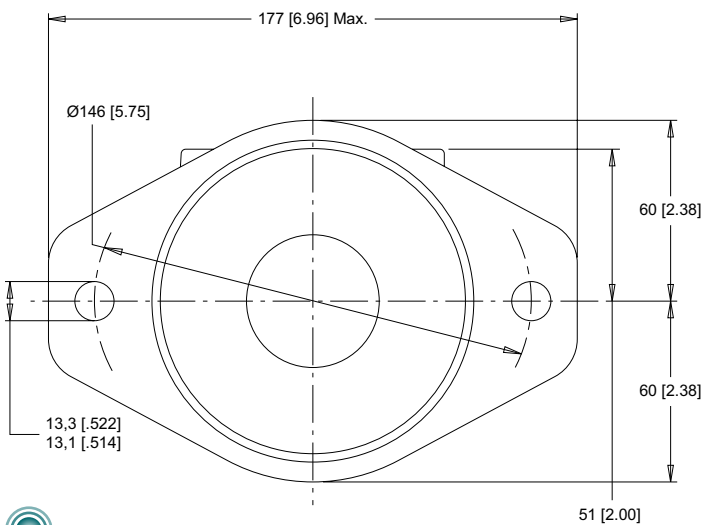

NOTE: Dimension C is found on page 12.



200 & 201 SERIES TECHNICAL INFORMATION

Bearing Curve: The bearing curve below represents the side load capacity of the motor at the centerline of the key for various motor speeds.

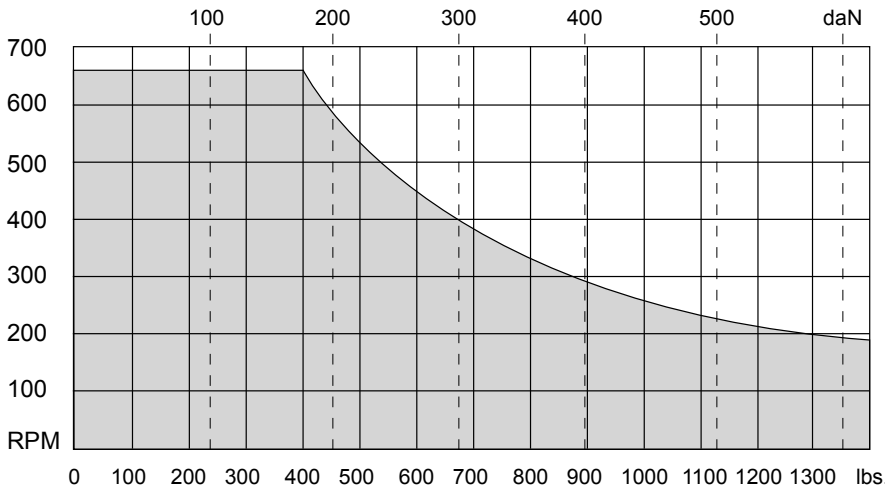

ALLOWABLE SIDE LOAD

Operating conditions within the shaded area will maintain acceptable oil film lubrication with recommended fluids. Operating conditions outside the shaded area are susceptible to motor failure due to oil starvation and/or excessive heat generation. Fluids with low lubricity or low viscosity may require the maximum load and speed ratings to be derated to provide acceptable motor life and performance.

THRUST LOAD

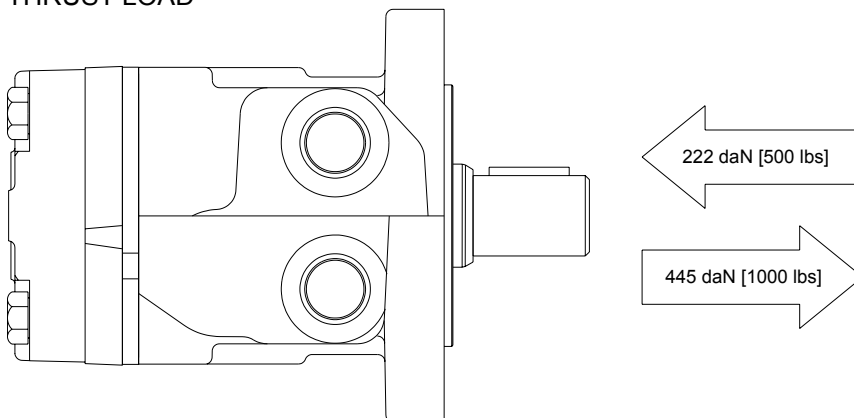

LENGTH / WEIGHT CHART SAE A Mount - Dimension A		
Code	mm [in]	kg [lb]
050	134 [5.29]	7,3 [16.1]
080	138 [5.44]	7,5 [16.5]
090	140 [5.51]	7,6 [16.8]
100	146 [5.75]	8,0 [17.7]
110	144 [5.65]	7,8 [17.2]
125	146 [5.75]	8,0 [17.7]
160	152 [5.97]	8,3 [18.2]
200	158 [6.22]	8,5 [18.8]
250	166 [6.53]	9,0 [19.8]
300	172 [6.76]	9,3 [20.5]
400	190 [7.47]	10,3 [22.7]

NOTE:
RS motor weights vary $\pm 0,5$ kg [1 lb] depending upon motor configuration.

LENGTH / WEIGHT CHART Square Mount - Dimension B		
Code	mm [in]	kg [lb]
050	136 [5.36]	6,1 [13.4]
080	140 [5.50]	6,3 [13.9]
090	142 [5.58]	6,4 [14.1]
100	148 [5.82]	6,9 [15.1]
110	145 [5.72]	6,6 [14.6]
125	148 [5.82]	6,9 [15.1]
160	153 [6.04]	7,0 [15.4]
200	160 [6.29]	7,3 [16.0]
250	167 [6.59]	7,8 [17.1]
300	173 [6.83]	8,1 [17.9]
400	192 [7.54]	9,2 [20.2]

NOTE:
RS motor weights vary $\pm 0,5$ kg [1 lb] depending upon motor configuration.

LENGTH / WEIGHT CHART SAE B Mount - Dimension C		
Code	mm [in]	kg [lb]
050	134 [5.29]	8,5 [18.6]
080	138 [5.44]	8,6 [19.0]
090	140 [5.51]	8,8 [19.3]
100	146 [5.75]	9,2 [20.2]
110	144 [5.65]	8,9 [19.7]
125	146 [5.75]	9,2 [20.2]
160	152 [5.97]	9,4 [20.7]
200	158 [6.22]	9,7 [21.3]
250	166 [6.53]	10,1 [22.3]
300	172 [6.76]	10,5 [23.0]
400	190 [7.47]	11,5 [25.2]

NOTE:
RS motor weights vary $\pm 0,5$ kg [1 lb] depending upon motor configuration.



200 & 201 SERIES SHAFTS

05 1" Pinhole

Max. Torque: 678 Nm [6000 lb-in]

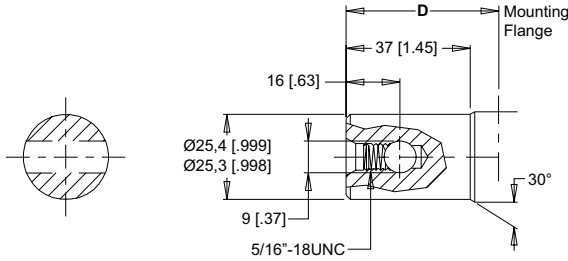

10 1" Straight

Max. Torque: 655 Nm [5800 lb-in]

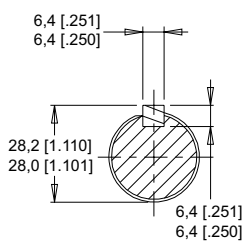

15 1" Straight Extended

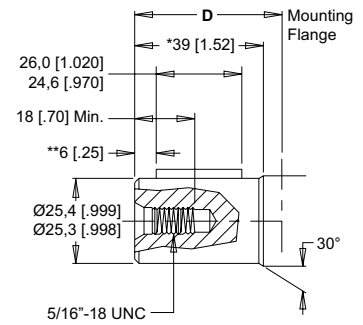

NOTE: * For 15 shaft add 13 [.53] ** For 15 shaft subtract 2 [.07]

13 1" Tapered

Max. Torque: 655 Nm [5800 lb-in]

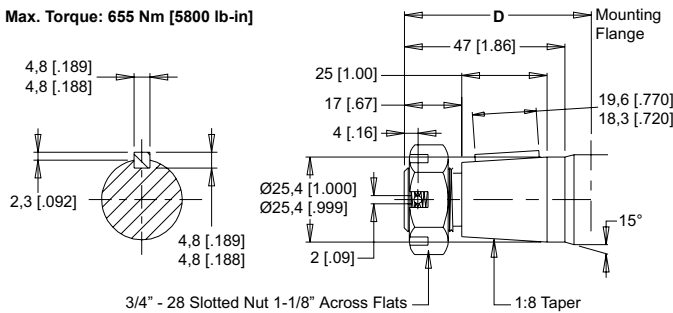

12 25mm Straight

Max. Torque: 678 Nm [6000 lb-in]

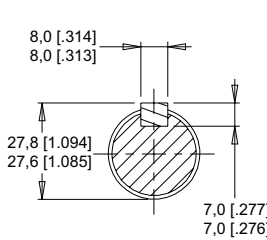

16 25mm Straight Extended

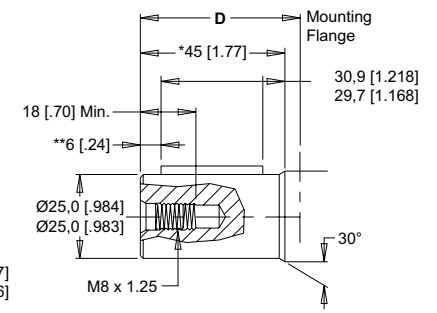

NOTE: * For 16 shaft add 7 [.28] ** For 16 shaft subtract 1 [.03]

01 13 Tooth Spline

Max. Torque: 170 Nm [1500 lb-in]

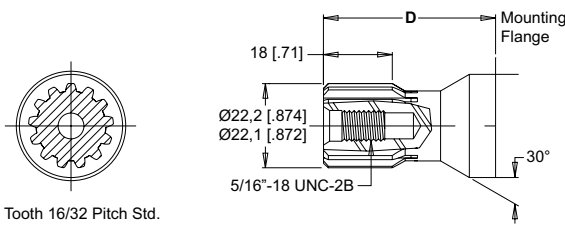

13 Tooth 16/32 Pitch Std. ANSI B92.1 - 1996 Spline

02 6-B Spline

Max. Torque: 429 Nm [3800 lb-in]

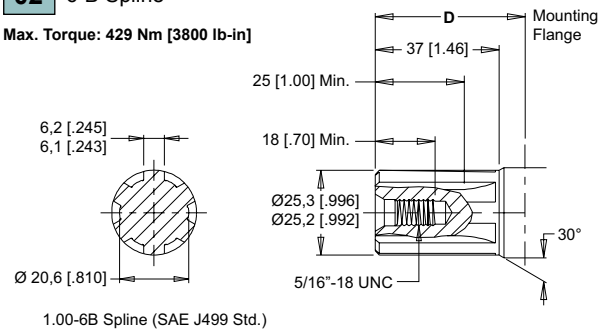

1.00-6B Spline (SAE J499 Std.)

MOUNTING FLANGE TO SHAFT END - Dimension D			
Code	SAE A Mounts	Square Mounts	SAE B Mounts
01	43 [1.70]	40 [1.57]	43 [1.70]
02	45 [1.77]	43 [1.70]	45 [1.77]
05	45 [1.77]	43 [1.70]	45 [1.77]
10	45 [1.77]	43 [1.70]	45 [1.77]
12	56 [2.20]	53 [2.09]	56 [2.20]
13	58 [2.28]	55 [2.17]	58 [2.28]
15	41 [1.61]	40 [1.57]	41 [1.61]
16	41 [1.61]	40 [1.57]	41 [1.61]

NOTE: Shaft lengths vary ± 0.8 mm [.030 in.]



200 & 201 SERIES MODEL CODE BUILDER

SERIES	DISPLACEMENT	HOUSING	SHAFT	PAINT	CAVITY	ADD ON	MISCELLANEOUS
STEP 1	STEP 2	STEP 3	STEP 4	STEP 5	STEP 6	STEP 7	STEP 8

STEP 1 - Select a series

- 200 Clockwise Rotation
- 201 Counterclockwise Rotation

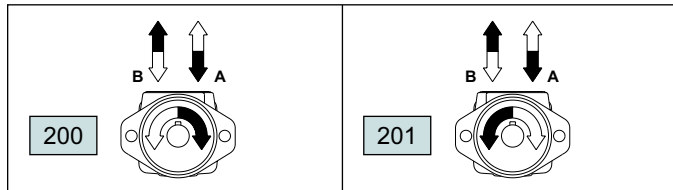

NOTE: For applications requiring the motor to rotate in only one direction, shaft seal life may be prolonged by pressurizing the "B" port of the motor. To obtain the desired direction of shaft rotation, use the graphic above to determine the rotation code for the motor. For bi-directional applications, the 200 series is recommended. Preferred rotation is based on rotor timing. Changing preferred direction requires no additional parts.

STEP 2 - Select a displacement option

050	52 cc	[3.2 in ³ /rev]	160	164 cc	[10.0 in ³ /rev]
080	76 cc	[4.6 in ³ /rev]	200	205 cc	[12.5 in ³ /rev]
090	89 cc	[5.4 in ³ /rev]	250	254 cc	[15.5 in ³ /rev]
100	103 cc	[6.3 in ³ /rev]	300	293 cc	[17.9 in ³ /rev]
110	111 cc	[6.8 in ³ /rev]	400	409 cc	[24.9 in ³ /rev]
125	127 cc	[7.7 in ³ /rev]			

STEP 3 - Select a housing option

- A10 2-Hole 1/2" NPT Aligned Ports (S)
- A11 2-Hole 7/8" O-ring Aligned Ports (S)
- A12 2-Hole 1/2" BSP.F Offset Ports (S)
- A13 2-Hole 1/2" BSP.F Offset Manifold (S)
- A17 2-Hole Manifold Ports (S)
- A18 2-Hole 1/2" BSP.F Aligned (S)
- A19 2-Hole 7/8" O-ring With Valve Cavity (S)
- A62 2-Hole 1/2" BSP.F Offset w/.200 Pilot
- A63 2-Hole 1/2" BSP.F Offset Manifold w/.200 Pilot
- A67 2-Hole Manifold Ports w/.200 Pilot
- A68 2-Hole 1/2" BSP.F Aligned w/.200 Pilot
- A70 2-Hole 1/2" NPT Side Ports (S)
- A71 2-Hole 7/8" O-ring Side Ports (S)
- A72 2-Hole 1/2" BSP.F Side Ports (S)
- B10 2-Hole SAE B Flange 1/2" NPT Aligned
- B11 2-Hole SAE B Flange 7/8" O-ring Aligned
- B18 2-Hole SAE B Flange 1/2" BSP.F Aligned
- B70 2-Hole SAE B Flange 1/2" NPT Side Ports
- B71 2-Hole SAE B Flange 7/8" O-ring Side Ports
- B78 2-Hole SAE B Flange 1/2" BSP.F Side Ports

STEP 3 (Continued) - Select a housing option

- F30 4-Hole 1/2" NPT Aligned Ports (S)
- F31 4-Hole 7/8" O-ring Aligned Ports (S)
- F37 4-Hole Manifold Ports (S)
- F39 4-Hole 7/8" O-Ring W/Valve Cavity (S)

STEP 4 - Select a shaft option

01	7/8" 13 Tooth	12	25mm Straight
02	1" 6-B Spline	13	1" Tapered
05	1" Pinhole	15	1" Straight Ext. (S)
10	1" Straight	16	25mm Ext. (S)

STEP 5 - Select a paint option

- A Black
- B Black (unpainted flange face)
- Z No Paint

STEP 6 - Select a valve cavity option

- A None
- B Relief Valve Cavity
- C 69 bar [1000 psi] Relief Valve Installed
- D 86 bar [1250 psi] Relief Valve Installed
- E 104 bar [1500 psi] Relief Valve Installed
- F 121 bar [1750 psi] Relief Valve Installed
- G 138 bar [2000 psi] Relief Valve Installed

NOTE: Valve cavity option is only available on the A19 and F39 housings.

STEP 7 - Select an add on option

- A Standard
- B Lock Nut
- C Solid Hex Nut
- W 4-Pin Dual Male Weatherpack Connector (S)
- X 4-Pin M12 Dual Male Connector (S)
- Y 3-Pin Single Male Weatherpack Connector (S)
- Z 4-Pin M12 Single Male Connector (S)

STEP 8 - Select a miscellaneous option

- AA None
- AC Freeturning Rotor

NOTE: (S) - STEP 3 Housings available for use with speed sensors. STEP 4 Shafts available for use with speed sensors. STEP 7 Speed sensor options.

Important Information

Before selecting or using a White Drive Products' product, it is important that all information concerning the product warranty, limitation of liability and responsibility of the customer be reviewed. This information is located below. Please direct any questions regarding this information to your White Drive Products representative.

Disclaimer

This catalog provides product options for further investigation by customers having technical expertise with respect to the use of such products. It is the responsibility of the customer to thoroughly analyze all aspects of the customer's application and to review the information concerning the product in the current product catalog. Due to the diversity of possible applications, the customer is solely responsible for making the final selection of the product(s) to be used and to assure that all performance, safety and warning requirements of the application are met. The customer is further responsible for all testing to verify acceptable life and performance of White Drive Products' products under actual operating conditions.

White Drive Products has made all reasonable efforts to present accurate information in this catalog and shall not be responsible for any incorrect information which may result from unintentional oversight. Due to continuous product improvement, the product specifications as stated in this catalog are subject to change by White Drive Products at any time without notice. The customer should consult a sales representative of White Drive Products for detailed information and to determine any changes in the information in this catalog.

Improper selection or improper use of the products described herein can result in death, personal injury and/or property damage. White Drive Products, Inc.'s sole responsibility with respect to its products is set forth in the warranty/limitation of liability policy state herein.

Warranty

White Drive Products' products are sold subject to a limited warranty and a limitation of remedies policy, both of which constitute part of any and all agreements to purchase White Drive Products' products. White Drive Products makes no other warranties or promises other than those specifically noted in its written policies, and no White Drive Products employee or agent has the power to alter those policies other than in writing.

OTHER FINE PRODUCTS AVAILABLE FROM WHITE DRIVE PRODUCTS



**A COMPLETE RANGE
OF LSHT HYDRAULIC
MOTORS**



**HYDRAULIC
CONTROLLED
PRESSURE
RELEASED BRAKES**

Delivering The Power To Get Work Done.

United States

White Drive Products, Inc.
P.O. Box 1127
Hopkinsville, KY. USA 42241
Phone: +1.270.885.1110
Fax: +1.270.886.8462
infousa@whitedriveproducts.com

Germany

White Drive Products GmbH
Halskestrasse 15
D-40880 Ratingen, Germany
Phone: +49 2102-1237770
Fax: +49 2102-1237779
infoeu@whitedriveproducts.com

China

White (China) Drive Products Co., Ltd.
1-8 Ning Zhen Gong Lu
Zhenjiang, 212021, Jiangsu, China
Phone: +86 511 5729988
Fax: +86 511 5728921
infochina@whitedriveproducts.com

Hong Kong

White Drive Products, Inc.
Asian Distribution Center
Unit 18, 9/F., Corporation Park
11 on Lai Street, Siu Lek Yuen
Shatin, N.T. Hong Kong
Phone: +852 2637 6682
Fax: +852 2637 6978
infohk@whitedriveproducts.com



whitedriveproducts

www.whitedriveproducts.com