



PUMP MOUNTS for ELECTRIC MOTORS

56C thru 145TC

182UC thru 184UC

Motor Size	56C	143TC	145TC	182UC	184UC
HP/1800 RPM	1/4-1/2	1	2	1	1 1/2
Shaft Diameter	.625	.875	.875	.875	.875
Key Size	3/16	3/16	3/16	3/16	3/16
Shaft Length	2.063	2.125	2.125	2.125	2.125

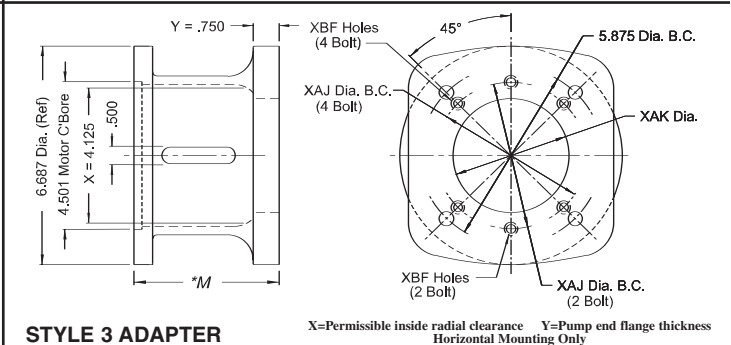
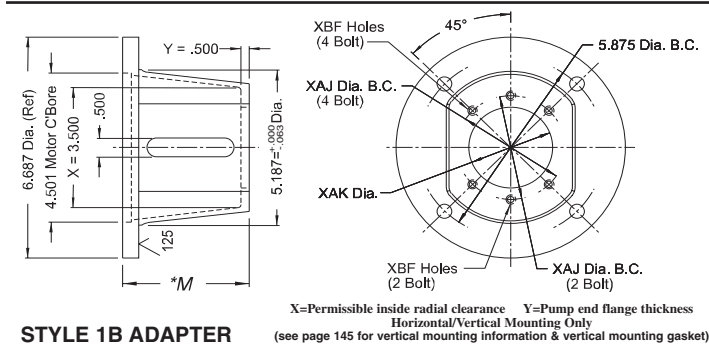
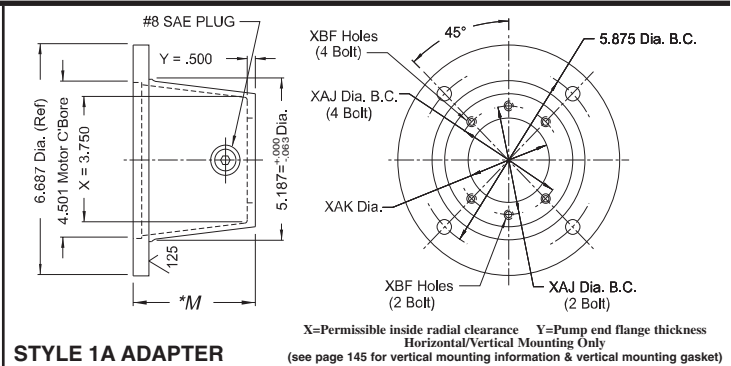
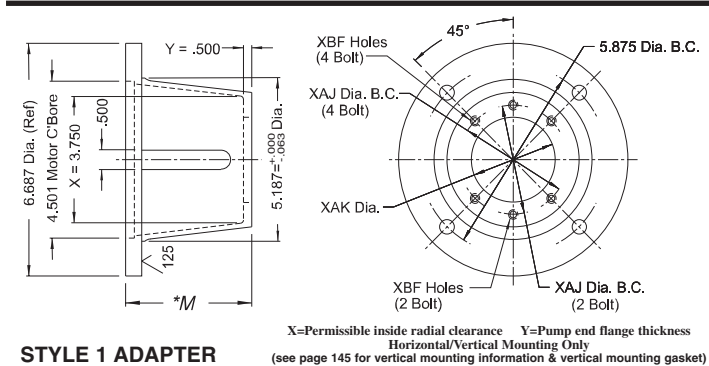

If your pump is not listed or is a non-standard pump, contact us for special machining and/or information. Not all pump mounting holes are supplied on every adapter.

Pump Type	Flange	XAJ Bolt Circle	XAK Pump Pilot	XBF Mounting Holes	Adapter Style	Mounting Horiz / Vert	Face to Face	Vescor Part Number
Standard SAE Pump Flanges	4 Bolt	2.84	1.781	5/16-18	1	yes yes	3.50	170599
					1A	yes yes	3.50	6094
					1B	yes yes	3.81	152199
					1	yes yes	4.25	6029
					1A	yes yes	4.25	6070
					1B	yes yes	4.50	150199
					1	yes yes	5.06	171399
					1B	yes yes	5.25	150799+
					1	yes yes	3.50	170699
					1A	yes yes	3.50	6093
					1B	yes yes	3.81	152299
					1	yes yes	4.25	6027
USA 4F17	2 Bolt	3.25	2.001	3/8-16	1A	yes yes	4.25	6095
					1B	yes yes	4.50	150299
					1	yes yes	5.06	171499
SAE AA	2 Bolt	4.19	3.251	3/8-16	1B	yes yes	5.25	150699+
					1A	yes yes	3.50	6091
					1A	yes yes	4.25	6071

*NON-STOCK SPECIAL ORDER ITEM (see page 142 for Motor Mounting Spacers)